

Kofax TotalAgility Administrator's Guide

Version: 8.0.0

Date: 2024-02-07

TUNGSTEN
AUTOMATION
FORMERLY KOFAX

© 2024 Tungsten Automation. All rights reserved.

Tungsten and Tungsten Automation are trademarks of Tungsten Automation Corporation, registered in the U.S. and/or other countries. All other trademarks are the property of their respective owners. No part of this publication may be reproduced, stored, or transmitted in any form without the prior written permission of Tungsten Automation.

Table of Contents

Preface.....	7
TotalAgility documentation.....	7
Training.....	7
Getting help with Kofax products.....	7
Chapter 1: About Transformation Server processes.....	9
High-priority incoming activities.....	9
Password-encrypted PDF files.....	9
Multiple instances of Transformation Server.....	9
Transformation Server pools.....	10
Partially completed activities.....	11
Stopping the Transformation Server service.....	12
Chapter 2: Kofax Reporting for the Capture Client.....	14
Activities recorded.....	14
Keystrokes.....	15
Chapter 3: Reporting service performance improvement.....	16
Chapter 4: TotalAgility Reporting database replication.....	17
Configure the thresholds for database growth.....	18
Chapter 5: Kofax Message Connector.....	19
Kofax Import Connector to TotalAgility.....	20
Ports usage.....	21
Deployment scenarios.....	21
Standalone scenario.....	22
Load-Balancing scenario.....	22
Failover scenario.....	23
High performance scenario.....	23
Configure Message Connector in Core Worker configuration.....	23
Disable Message Connector in TotalAgility.....	24
Advanced configuration of Message Connector features.....	24
Set Windows permissions for Message Connector.....	25
Folder permissions.....	25
Features and integration examples.....	25
Connection modes.....	25
Connect to Biscom server.....	27
Connect to RightFax server - COM API.....	28

Connect to RightFax fax server - Rest Web API.....	30
Connect to Kofax Communication Server.....	35
Import PST files.....	35
PDF normalization.....	36
Configure document normalization.....	37
Configure Kofax Converter.....	39
Date/Time format.....	44
Import MSG and EML files from folder.....	44
Import XFA files.....	45
Archive documents.....	46
Configure SSL connection.....	46
Filter source IP addresses for SMTP connections.....	48
Access other user's mailbox.....	49
Permissions for OAuth.....	49
Registry settings to enable TLS v1.1 and TLS v1.2 support for EWS.....	50
Windows Failover Clustering.....	53
Network Load Balancing.....	55
Operation and maintenance.....	58
Manage logs in Message Connector.....	58
Manage logs in KFXConverter.....	58
Message Connector status monitor.....	58
Send test messages.....	59
Message Connector storage.....	59
View messages in the storage.....	60
Manage failed messages manually.....	60
Chapter 6: Kofax Document Converter.....	62
Advanced configuration for document preparation.....	62
Configure PDF variant.....	63
Configure Microsoft Office.....	64
Configure OpenOffice.org extension.....	64
Configure Total HTML ConverterX.....	65
Configure Kofax Converter.....	65
Flatten XFA files.....	65
Image normalization rules.....	66
Manage conversion time for large files.....	67
Chapter 7: Assign TotalAgility access permissions.....	68
Chapter 8: Log on to TotalAgility in recovery mode.....	69
Appendix A: Security and compliance.....	70

User login and authentication.....	70
Client transmits to Kofax TotalAgility server(s).....	71
Kofax TotalAgility server(s) transmits to another Kofax TotalAgility server(s).....	71
Kofax TotalAgility servers transmit to SQL server.....	71
Image and metadata storage.....	72
Appendix B: Active Directory synchronization.....	73
Active Directory domains.....	73
Child domain.....	73
Additional domain (Cross domain).....	73
Forests and trees.....	73
LDAP (Lightweight Directory Access Protocol).....	73
LDAP query.....	74
Referral chasing.....	74
Active Directory attributes.....	74
Implement Active Directory synchronization.....	74
Synchronize active items.....	74
Synchronize deleted items.....	75
Synchronize root level.....	75
Synchronize middle level.....	75
Perform group search.....	75
Synchronize cross domains.....	76
Synchronize category within category.....	76
Synchronize groups within groups.....	76
Implement chase referral.....	77
Appendix C: Lock activity performance.....	78
Appendix D: CoreWorkerActivityOrder setting.....	79
Lock activities.....	79
Appendix E: Cross Origin Resource Sharing setting.....	81
Appendix F: Logging.....	82
TotalAgility Web and Application Server.....	82
TotalAgility Transformation Server.....	84
Data Layer.....	87
Capture Client.....	88
TotalAgility Reporting Server.....	89
Client-side reporting.....	90
Web Capture logging.....	91
Network logging.....	91
License Server logging.....	92

KFXConverter.....	92
Message Connector.....	92
Document Converter.....	93
Appendix G: Performance counter usage.....	94
Installation.....	94
Data collection.....	94
Interpretation.....	95
Locked automatic activities.....	95
Worker tasks taken.....	95
Active threads / Thread pools.....	96
Items / Thread pool queue.....	96
Uninstall.....	96
Logging.....	96
Appendix H: Supported input and output file formats.....	98
Supported formats for document normalization.....	98
Supported formats for document conversion.....	99
Attachment Encoding.....	101
Input and output formats for a Document Converter.....	101
Input and output formats for a Message Connector.....	102
Supported input formats and PDF output formats.....	103

Preface

Use the information in this guide if you are the administrator who will configure and maintain the TotalAgility installation.

TotalAgility documentation

Access the full documentation set online, from the [Kofax TotalAgility Documentation page](#).

You can also access the TotalAgility documentation in offline mode by downloading it from the Kofax Fulfillment Site for each language separately.

For a full documentation set, and how to access the documentation in offline mode, refer to the *Kofax TotalAgility 8.0.0 Release Notes*.

Training

Kofax offers both classroom and online training to help you make the most of your product. To learn more about training courses and schedules, visit the [Kofax Education Portal](#) on the Kofax website.

Getting help with Kofax products

The [Kofax Knowledge Portal](#) repository contains articles that are updated on a regular basis to keep you informed about Kofax products. We encourage you to use the Knowledge Portal to obtain answers to your product questions.

To access the Kofax Knowledge Portal, go to <https://knowledge.kofax.com>.

 The Kofax Knowledge Portal is optimized for use with Google Chrome, Mozilla Firefox, or Microsoft Edge.

The Kofax Knowledge Portal provides:

- Powerful search capabilities to help you quickly locate the information you need.
Type your search terms or phrase into the **Search** box, and then click the search icon.

- Product information, configuration details and documentation, including release news.
To locate articles, go to the Knowledge Portal home page and select the applicable Solution Family for your product, or click the View All Products button.

From the Knowledge Portal home page, you can:

- Access the Kofax Community (for all customers).
On the Resources menu, click the **Community** link.
- Access the Kofax Customer Portal (for eligible customers).
Go to the [Support Portal Information](#) page and click **Log in to the Customer Portal**.
- Access the Kofax Partner Portal (for eligible partners).
Go to the [Support Portal Information](#) page and click **Log in to the Partner Portal**.
- Access Kofax support commitments, lifecycle policies, electronic fulfillment details, and self-service tools.
Go to the [Support Details](#) page and select the appropriate article.

Chapter 1

About Transformation Server processes

TotalAgility uses the Transformation Server to process automatic activities (including Composite, Extraction, Classification, PDF Generation, and Image Processing). Multiple Transformation Servers can work within a single Kofax TotalAgility installation. Server software processes concrete tasks such as Classification. Transformation Server is designed as a separate component to remove CPU intensive processing from application and web servers on separate machines, thus allowing these components to be more responsive.

Transformation Server connects with Kofax TotalAgility using direct database access with the SQL Server ADO.NET driver.

High-priority incoming activities

The Transformation Server normally uses an outgoing model where each Transformation Server periodically polls Kofax TotalAgility for new jobs. When a process requires an immediate response from a Transformation Server, create a job using the CreateJobAndProgress API. This performs a synchronous activity that executes all capture activities as quickly as possible through Transformation Server and then stops at the first manual activity in a process (such as Validation).

Transformation Server uses all available slots to process the pushed calls, and you can add the reserved slots to increase responsiveness on push calls. Reserved slots only guarantee that processing can be started immediately. However, if all slots are busy (include reserved ones), the call will wait.

Password-encrypted PDF files

You cannot use Transformation Server to process password-encrypted PDF files. Decrypt the password-encrypted files before passing them to Transformation Server.

Multiple instances of Transformation Server

You can run multiple instances of Transformation Server as part of your TotalAgility environment. You can add or remove instances of the Transformation Server without reconfiguring Transformation Server and TotalAgility itself.

Transformation Server pools

In a system where all activities require a similar amount of processing time, use multiple Transformation Servers in a single pool. For greater control over more complex processes, use Transformation Server pools.

For example, in a medical claims processing solution, claims arrive in the following ways:

- Mail room: Large numbers of claims arrive through the mail room and are manually fed into high-speed scanners with 200 to 500 pages in each group. The system is continuously loaded.
- Internet Portal: Individual claims and small groups of claims arrive through the Internet portal.
- Mobile Devices: Individual claims arrive through mobile devices.

The system must acknowledge receipt of claims that arrive from the portal and mobile devices. Submissions through these devices are random and peaks are difficult to predict.

The large number of claims that arrive through the mail room can take longer to process than the individual claims and smaller groups that arrive through the Internet and mobile devices. If Transformation Server processes claims based on arrival time, an individual claim might be scheduled behind a large group of claims from the mail room. The processing time for the individual claim might be excessive.

Adding Transformation Server pools can prevent this problem. When designing the TotalAgility workflow, create separate processes for urgent jobs from the Internet portal and mobile devices, and long-running jobs from the mail room. Specify a Transformation Server pool for each Transformation Server supported activity, such as PDF Generation and Composite.

Example:

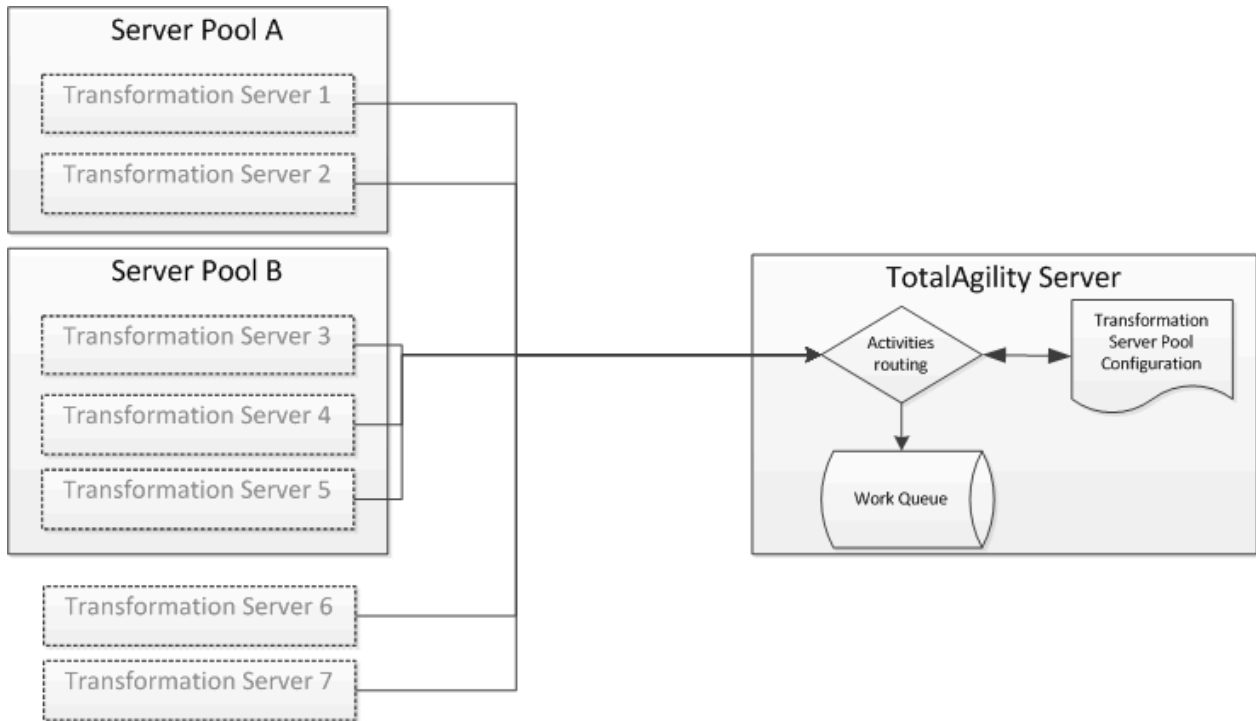

This example shows three pools:

- Pool A: Processes urgent jobs from the Internet portal or mobile devices.
- Pool B: Processes long-running jobs from the mail room.
- Default Pool: Processes activities regardless of the assigned pool.

A Transformation Server can belong to only one pool.

- Transformation Server instances 1 and 2 are assigned to process activities from Pool A.
- Transformation Server instances 3 to 5 are assigned to process activities from Pool B.
- Transformation Server instances 6 and 7 are not assigned to a pool, so they execute all activities regardless of the assigned pool.

Partially completed activities

If you enable partial completion in a Transformation Server activity (including Composite, Extraction, Classification, and PDF Generation), the Transformation Server notifies TotalAgility when a document in a folder is fully processed and ready for further processing, even though other documents in a folder are not yet ready for processing.

i For an activity using the Partial Completion property, the folder structure validation logic is not executed by Transformation Server. For more information on the Partial Completion property, see the *Kofax TotalAgility Help*.

Stopping the Transformation Server service

The Transformation Server Service can be controlled like other services from the command line or with Services under the Control Panel.

However, when the service receives the command to stop, the service is only allowed a limited time to end. The following steps occur when using the normal method of stopping the Transformation Server Service:

1. The service stops accepting or taking new work from the TotalAgility Core Worker.
2. The service continues to process unfinished activities for a limited time, which is usually less than two minutes.
3. Any activities that do not complete with this limited time are interrupted and suspended.
4. The service stops.

If you need more than a couple of minutes for activities to finish processing, you can send the following custom command to the service to stop it gracefully:

```
sc control KofaxTransformationServerService 186
```

When the service receives this custom command, the service may continue to run until it is idle. The following steps occur when you use the custom command to stop the Transformation Server Service:

1. The service stops accepting or taking on new work from the TotalAgility Core Worker.
2. The service continues to process unfinished activities for an indefinite time.
3. When all activities are complete, the service stops.

i If non-responsive background processes are not detected, the service may never end. However, 24-hour timeouts are likely to end any non-responsive processes.

In this case, the cause is likely a non-responsive child background service, and the standard stop command will end the process.

The service also allows Pause and Continue commands.

- Pause: The service continues to process current activities, but does not accept or take on new activities. The service eventually goes idle, but does not stop or exit.
- Continue: The service resumes taking new activities.

The command line syntax for all aspects relating to the Transformation Server service are as follows.

Syntax	Description
<code>sc start KofaxTransformationServerService</code>	The standard start command for the service.
<code>sc stop Kofax TransformationServerService</code>	The standard stop command for the service.
<code>sc control KofaxTransformationServerService 186</code>	The custom stop command that allows all current work to complete before the service stops.

Syntax	Description
<code>sc pause KofaxTransformationServerService</code>	The command to pause the service.
<code>sc continue KofaxTransformationserverService</code>	The command to start the service again after is has been paused so that the normal activity can resume.

Chapter 2

Kofax Reporting for the Capture Client

Kofax Reporting provides information about Kofax TotalAgility usage, including scanning, review, validation, verification, import, and export. This feature enables you to track the efficiency of the system and users.

The server records Capture Client activities and sends the information to the reporting library whenever an activity occurs that requires reporting.

Activities recorded

All document and page editing activities are recorded, including those performed by custom .NET activities. Recorded activities include:

- Document actions:
 - Create
 - Delete
 - Override/restore document problem
 - Reject/unreject document
- Page actions:
 - Annotate/Remove annotation
 - Delete
 - Rotate

The following Capture Client activities have special labels:

- Page creation activities (whether by scanning or importing) are recorded as **Page scan** actions.
- Moving a document within a folder, to a different folder, and moving a folder with a document generates a **Document move** action.
- Moving a page within a document generates a **Page move** action for the following operations:
 - Moving a page within a document.
 - Moving a page from one document to another.
 - Splitting a document with the MovePages parameter.
 - Combining documents.

Validation and Document Review modules maintain document separation statistics for the following activities:

- Correct splits
- Wrong splits

- Missing splits

These statistics are reported to the server when the activity is completed.

Keystrokes

Keystrokes are counted for documents and fields. A Complete activity causes the following to happen:

- Documents with positive key counts are included in the event data passed to the server.
- The keystroke counter is reset to zero.

Keystrokes used in folder operations are not reported.

The following rules determine how the system records keystrokes and whether the rules apply to documents or fields:

Recorded keystrokes on the document

- Field navigation keys (Tab, Up Arrow, and Down Arrow)
- Keystrokes on read-only and disabled fields
- Keystrokes that change a document field
- Keystrokes made on the Document Type field

Recorded keystrokes on the field

- Confirmation keys (Enter to confirm and Ctrl+Enter to force validation)
- When the focus is on the Navigator, Image View, Thumbnails, and Current Error panels, keys pressed to bring the focus to the active field (as highlighted in yellow)—recorded as keystrokes on the field. The exception is Enter, which is recorded as a keystroke on the document.
- All other keystrokes that are sent to a field—recorded as keystrokes on the field and on the document.

Keystrokes that are not counted

- Keystrokes made on the Folder and Activities tabs
- The Alt, Shift, Ctrl, and Print Screen keys

Chapter 3

Reporting service performance improvement

Hardware scalability (vertical scalability) is important for performance control depending on the size of the processed and/or stored data.

The performance of Reporting service may decrease as data accumulates in Staging and/or Warehouse databases. Therefore, you must take into account the following hardware scalability:

- Increase the number of processors on the computer running Reporting service. This does not affect the performance of Reporting service because it is a single-threaded application.
- Increase the number of processors for SQL server. This can slightly improve performance, particularly if SQL Server processes requests from many applications.
- Increase the size of the disk for Reporting service databases. This does not increase performance regardless of the size of the databases.
- Increase the I/O speed of the disk on which Reporting databases are located. This increases the performance of the Reporting service, regardless of the size of the databases.
- Increase the amount of RAM on the SQL server computer. This avoids significant performance degradation when the database size increases. For the Reporting service version 7.10, increasing the amount of RAM on the SQL server computer applies mainly to the Warehouse database and to a lesser extent to the Staging database. For earlier versions, this applies to both the databases.

Chapter 4

TotalAgility Reporting database replication

Kofax TotalAgility Reporting is represented by two databases: Staging and Warehouse. For an on-premise installation, the default names are TotalAgility_Reporting_Staging] and TotalAgility_Reporting. For an on-premise multi tenant installation, the database is single per tenant and it contains the tables from both databases, Staging and Warehouse.

For database replication, the Reporting databases and tables should be created on the server where data will be replicated. This can be done by running the Kofax TotalAgility installer with the option to create only databases. To configure replication for the Reporting databases, the following tables should not be included into articles for publication.

tmp_batch_edit	tmp_delete_doc_dim
tmp_batch_field	tmp_doc_accum_fact
tmp_change_details_batch_act	tmp_doc_dim
tmp_change_details_doc_act	tmp_doc_export_fact
tmp_change_details_field_act	tmp_doc_object_audit_fact
tmp_change_details_folder_act	tmp_doc_sess_snapshot_fact
tmp_change_details_general_act	tmp_event_data_dim_doc
tmp_change_details_page_act	tmp_event_data_dim_page
tmp_folder	tmp_field_accum_fact
tmp_kc_batch_action	tmp_field_aggregate_fact
tmp_status_kc_doc	tmp_field_changes_fact
tmp_status_kc_doc_field	tmp_field_column_dim
tmp_status_kc_doc_page	tmp_field_dim
tmp_workstation	tmp_folder_object_audit_fact
tmp_batch_accum_fact	tmp_gen_object_audit_fact
tmp_batch_dim	tmp_group_value_dim
tmp_batch_edit_fact	tmp_page_dim
tmp_batch_field_fact	tmp_page_object_audit_fact
tmp_batch_object_audit_fact	tmp_path_dim
tmp_batch_sess_snapshot_fact	

`Replication_Reporting_Staging.sql` and `Replication_Reporting_Warehouse.sql` are the sample scripts for Reporting database replication available at the following location from your TotalAgility product installation files.

```
\\TotalAgility\TotalAgilityInstall\DatabaseScripts\SQL Server\Reporting
```

Configure the thresholds for database growth

You can monitor the Reporting database tables growth by configuring custom job for the Microsoft SQL Agent service. The query for creating a job contains the parameters that allow you to configure the thresholds for growth warnings. To locate the query example, navigate to `TotalAgilityInstall\DatabaseScripts\SQL Server\Reporting\DB Growth Scripts` from your Kofax TotalAgility installation files.

Chapter 5

Kofax Message Connector

Kofax Message Connector is a Windows service responsible for importing messages and files in many electronic formats. Kofax Message Connector can retrieve documents using one of the following connection modes:

- Storage mode: Retrieves documents from various sources and saves them in internal storage, which is available for retrieval using a web service interface. TotalAgility connects to the Message Connector web service interface and retrieves the documents for import. This mode is recommended for larger jobs.
- Direct Mode: Retrieves documents from various sources and directly imports them to TotalAgility.

See [Connection modes](#).

Kofax Message Connector can import messages and files from:

- Email messages including attachments using various email protocols (SMTP, POP3, IMAP, EWS, MS Graph)
- Fax messages (through internal fax over IP server or external fax servers: Kofax Communication Server, RightFax, Biscom)
- Files from a local or network folder

This chapter provides important information about configuring and operating Kofax Message Connector, including:

- Instructions for configuring Kofax Message Connector.
- Instructions for integrating in a third-party environment, such as fax servers or email servers.
- Instructions for operating and monitoring Kofax Message Connector.

This chapter also describes scenarios where you can install multiple Message Connector instances on the same computer. This configuration is only useful in specific scenarios, such as:

- Network load balancing scenario (active/active Windows cluster). See [Network Load Balancing](#).
- Setup for elementary prioritization of Message Connectors. See [Load-Balancing Scenario](#).



- Kofax Message Connector is also used with slightly different functionality in other Kofax products.
- For using the Message Connector utility in Docker, start the utility remotely from the Message Connector Monitor.
- You cannot use MS Office, Open Office, Total HTML Converter, Total EML Converter for converting office documents in a Docker environment.

Kofax Import Connector to TotalAgility

To migrate from Kofax Import Connector to TotalAgility, configure specific settings in TotalAgility to make sure that your existing import configuration remains intact. Identify the existing metadata fields in your Kofax Import Connector destination configuration and map them to the corresponding metadata fields of import sources in TotalAgility.

See the following table for the Kofax Import Connector message fields and the corresponding TotalAgility metadata fields.

Kofax Import Connector message fields	TotalAgility metadata fields	IMAP/EWS/POP3/ SMTP	External fax server/FOIP	File
KfxImportFolderName	Message Import Folder	Yes		
KfxMessageAttachmentList	Message Attachment List	Yes		Yes
KfxMessageCorrelation	Message Correlation	Yes	Yes	Yes
KfxMessageDeliveryPriority	Message Delivery Priority	Yes	Yes	Yes
KfxMessageDeliverySuspectedDupli	Message Suspected Duplication	Yes	Yes	Yes
KfxMessageDeliveryType	Message Delivery Type	Yes	Yes	Yes
KfxMessageFileName	Message General File Name		Yes	
KfxMessageID	Message ID	Yes	Yes	Yes
KfxMessageOwnerReference	Message Owner Reference	Yes	Yes	Yes
KfxMessagePages	Pages		Yes	
KfxMessageReceptionCallerId	Message Reception Caller Id		Yes	
KfxMessageReceptionErrorImporting	Message Importing Error	Yes	Yes	Yes
KfxMessageReceptionErrorInfo	Error information	Yes	Yes	Yes
KfxMessageReceptionErrorLevel	Error Level	Yes	Yes	Yes
KfxMessageReceptionTimeCreated	Message Reception Time Created	Yes	Yes	Yes
KfxMessageReceptionTimeReceived	Message Reception Time Received	Yes	Yes	Yes
KfxMessageSubject	Subject	Yes	Yes	Yes
KfxMessageTimePosted	Time Posted	Yes		
KfxOriginalRecipients	Import Source Recipients	Yes	Yes	Yes
KfxOriginatorName	Message Originator Name	Yes	Yes	Yes
KfxOriginatorNumber	Message Originator Number	Yes	Yes	Yes
KfxOriginatorService	Message Originator Service	Yes	Yes	Yes

Kofax Import Connector message fields	TotalAgility metadata fields	IMAP/EWS/POP3/ SMTP	External fax server/FOIP	File
KfxRecipientName	Message Recipient Name	Yes	Yes	Yes
KfxRecipientNumber	Import Source Address	Yes	Yes	Yes
KfxRecipientService	Message Recipient Service	Yes	Yes	Yes
KfxRecipientsBCC	Bcc	Yes		Yes
KfxRecipientsCC	CC	Yes		Yes
KfxRecipientsTo	To	Yes		Yes
KfxRoutingNumber	Message Routing Number	Yes	Yes	Yes

Ports usage

With the default configuration, Message Connector uses TCP port 25086, which is used for the web interface between TotalAgility and Message Connector.

Additional ports are used on the basis of the configured features:

Port	Used for
TCP port 25	SMTP
TCP port 1720	Fax over IP via H.323
UDP port 5060	Fax over IP via SIP
UDP port 10000-10999	Fax over IP for voice/T.38 media data
TCP ports 25087, 25088	Web services

If other applications use any of these ports, change them in the Message Connector configuration. Firewall or anti-virus software may block traffic on the ports, especially port 25. In case of connection problems, review the settings for these applications.

Deployment scenarios

This section describes typical deployment scenarios for connecting Kofax Message Connector with the Core Worker service. One Core Worker service can connect to multiple Message Connectors. However, a single Message Connector must not be polled by multiple Core Worker services. Although, we recommend that you assign each Core Worker to a Message Connector.

Irrespective of the deployment scenario, use one of the following configurations when configuring Message Connectors with the Core Workers:

- Use only one Core Worker to poll all Message Connectors.
- Add an additional application server and assign each Core Worker to a Message Connector.

- [Configure each Core Worker with a Message Connector](#) and [disable unused Message Connectors](#) in TotalAgility. In this case, Message Connector and Core Worker are not installed on the same machine.

i To restrict the HTTP access of Message Connector for security reasons, we recommend that you set the Local IP Address field in the HTTP settings using one of the following.

- Specify the local IP address (127.0.0.1) to limit the access to a local machine in case of a standalone deployment.
- Specify the local IP address of any network adapter to limit the access to a specific network.

In TotalAgility, when configuring the import connection settings for emails, make sure that you specify the same IP address in the Message Connector URL field on the "Import connections" page.

Note that for optimal performance, Kofax Message Connector and the Core Worker service must be installed on the same computer.

Standalone scenario

In this scenario, Message Connector and Core Worker service are installed on the same computer. This configuration does not offer any load balancing or failover mechanisms. You can easily run this scenario in a virtual environment for tests and demonstrations.

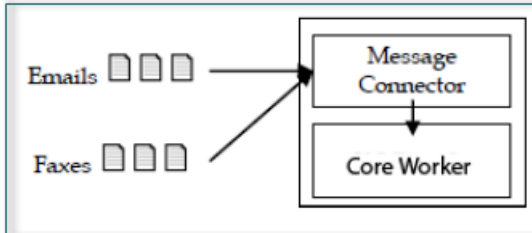

Load-Balancing scenario

In this scenario, a single instance of the Core Worker service connects to two or more Message Connector instances. Each instance runs on a separate computer. This configuration is recommended if you need to process many messages quickly. As document conversion can be time-consuming with multiple Message Connectors, you can distribute the conversion load to several computers.

You can also install multiple instances of Message Connector on a single computer. This does not speed up document processing but helps you to prioritize documents. For example, suppose that a customer expects a high volume of email traffic and some high-priority faxes. Customer expects large volume of email traffic and fewer high-priority faxes. By assigning fax import to a dedicated instance of Message Connector, the customer can ensure that faxes are not stalled in the queue behind emails.

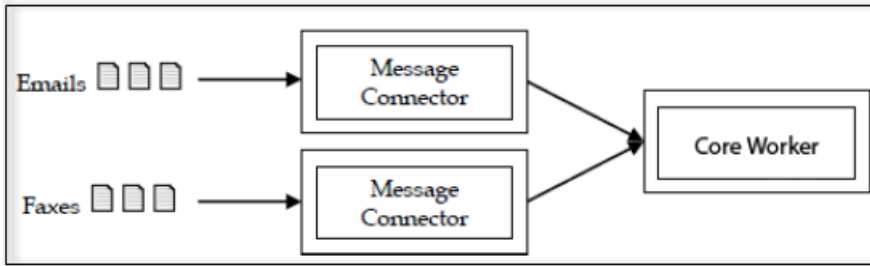

Failover scenario

In this scenario, two or more computers with Kofax Message Connector are grouped in a Windows failover cluster. Documents are routed to the active node. When that fails, the next node continues without longer service interruption. See [Windows Failover Clustering](#).

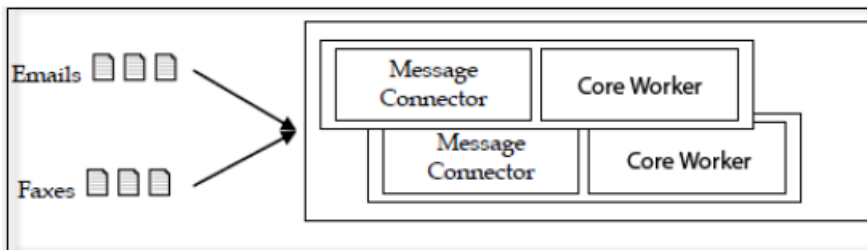

High performance scenario

In this scenario, multiple computers run in parallel and import documents from a folder.

For optimal performance, install both Message Connector and Core Worker service on the same computer. Modify the value of the `Prefetched Messages` parameter in the Message Connector configuration to optimize performance. In our high-performance environment, the value 40 has yielded the best results.

Configure Message Connector in Core Worker configuration

To configure Message Connector in the Core Worker configuration, do the following for each Core Worker:

1. Open the `C:\Program Files\Kofax\TotalAgility\CoreWorkerService\Agility.Server.Core.WorkerService.exe.config` file in a text editor.
2. Search for the following string: `ImportConnectorName`.
The following string is displayed:

```
<add key="ImportConnectorName" value="" />
```
3. Specify the Import connection name as assigned in TotalAgility Designer.
For example, if the Import connection name is "Testconnection", specify:

```
<add key="ImportConnectorName" value="Testconnection" />
```

i Specify only one Message Connector (ImportConnectorName field) in the Core Worker configuration (Agility.Server.Core.WorkerService.exe.config) file; therefore, you cannot configure multiple Message Connectors for a Core Worker.

4. Save and close the file.
5. Repeat the preceding steps for all Core Workers until each one is connected to an individual Import connection (Message Connector).

Disable Message Connector in TotalAgility

To disable any unused Message Connector (Import connection), do the following in TotalAgility Designer:

1. Navigate to **Integration > Import settings**.
2. Double-click the Import connection that is not mapped to any Core Worker.
3. Clear the **Active** check box.
4. Save and close the Import connection.

Advanced configuration of Message Connector features

In most use cases, it is sufficient to configure the import settings in the Kofax TotalAgility integration import configuration user interface.

For specific use cases, some advanced configuration parameters are available in a separate Message Connector Configuration user interface.

To open the Message Connector Configuration, from the Windows Start menu, select **All Programs > Kofax > Message Connector > Message Connector Configuration**. The Message Connector Configuration screen appears.

The following configuration parameters do not apply to Kofax TotalAgility.

Tab	Configuration Parameter
Security Options	<ul style="list-style-type: none"> • Disable Web Service Input
Document Conversion	<ul style="list-style-type: none"> • Image to PDF
Web-Service Input	<ul style="list-style-type: none"> • Local IP Address • HTTP Port • HTTPS Port • KC Plugin URL • MC Cluster Enabled • Local MC Cluster IP Address • MC Cluster Port • MC Cluster Members

Set Windows permissions for Message Connector

This section provides information about the Windows permissions required to run Message Connector.



- The user who performs the installation must be a member of the local Administrator's group.
- Only an interactive user (logged-on user), or a user defined in the Message Connector Document Conversion configuration can perform the Microsoft Office document conversion.

Folder permissions

The following table lists the necessary folder permissions to run Message Connector.

Folder	Permission
ProgramData\Kofax\KIC-ED\MC	Full Control
Installation folder Message Connector installation folder.	Read
Temp folder (generally, Windows\Temp) You can modify this folder using Windows environment variables.	Full Control

Features and integration examples

This section provides examples on how to integrate Kofax Message Connector with third-party software and hardware, and describes some advanced product features.

Connection modes

Message Connector can be configured in two different modes to connect and retrieve documents: Storage and Direct. By default, both the modes are enabled in Message Connector Configuration. See *Kofax TotalAgility Designer Help*.

Storage mode

In this mode, Message Connector retrieves documents from the import sources and stores them. TotalAgility then connects to the Message Connector web service interface and retrieves the documents for import. Each Message Connector requires a separate Integration Server to connect with a TotalAgility Tenant.

Direct mode

In this mode, Message Connector retrieves documents from the import sources and are directly retrieved by TotalAgility. In this mode, Message Connectors can connect with TotalAgility without any Integration Server.

Multiple TotalAgility tenants can use the same Message Connector. Up to 100 Tenants with an average number of 10 passive inputs are supported by each Message Connector. Tenants may use one or more Message Connector connections, or none at all.



- Message polling using FoIP, SMTP and POP3 is not available.
- Direct mode is available for both On-premise and On-premise multi-tenant installations.
- The Enable SMTP server and Enable FoIP server options are not available when configuring Import connections in TotalAgility Designer.
- The Send test fax and Inbound/outbound status views are not available in Message Connector Monitor.

Example configurations

A system with 200 Tenants is configured to use two Message Connectors.

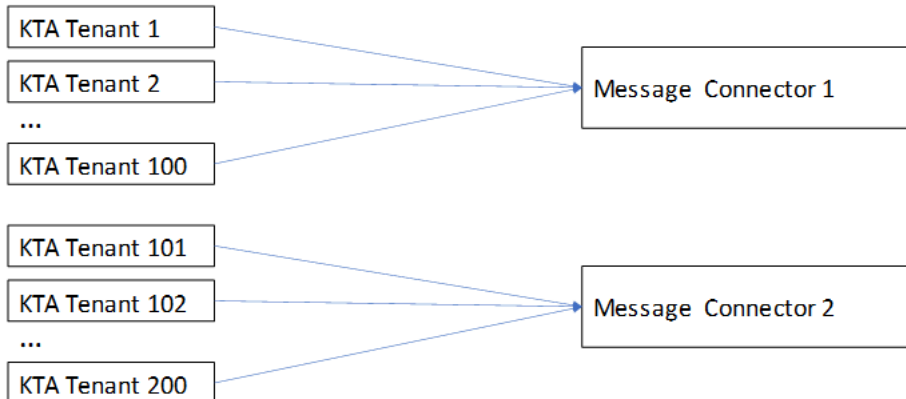

A system with 100 Tenants is configured to use one Message Connector for most inputs. A second Message Connector is available with a different configuration (such as, advanced trace settings). Tenants may use none, one or more Message Connector connections.

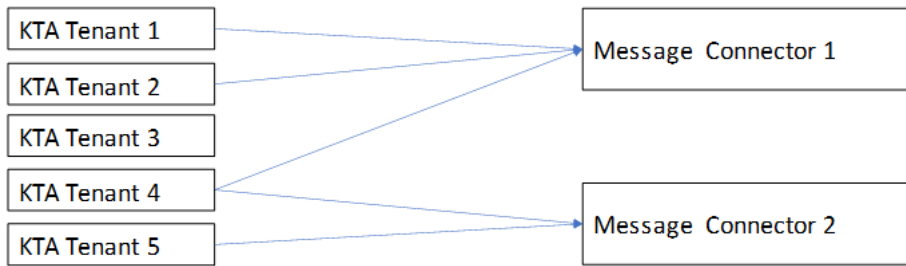

Connect to Biscom server

In addition to configuring the connection to the Biscom fax server in TotalAgility Designer, install the Biscom client software and identify a user or extension on the fax server for use with Kofax Message Connector. Work with your fax server administrator to configure the Biscom server.

Configure Biscom server

1. On the Biscom fax server, start the FAXCOM Administrator tool.
2. Create (or reserve) a user or extension for use with Kofax Message Connector.
3. Enable the network share connection to the Biscom server and note the service path.
4. Close the tool.

Install FAXCOM client

Install the Biscom client software, the FAXCOM client, on any computer where Message Connector is installed.

1. Run the following command if the computer in which the FAXCOM client is installed belongs to a Windows domain and the user does not have access rights to the Biscom share:

```
Net Use <Biscom_service_path> /USER:<Biscom_user> <password>
```
2. Start the FAXCOM client from the FAXCOM group on the Windows Start menu.
3. Enter the logon information and click **OK**.
Upon logon, the FAXCOM client window opens.

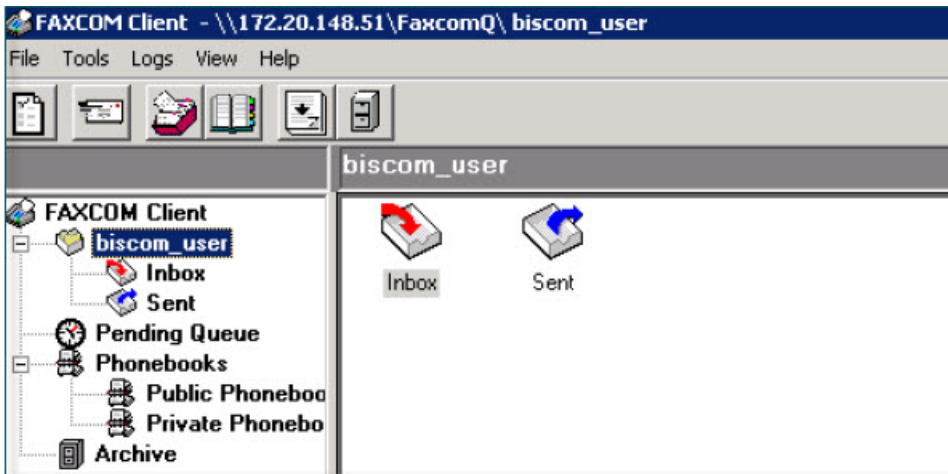

4. Close the client.

Connect to RightFax server - COM API

In addition to configuring the connection to the RightFax fax server in TotalAgility Designer, install RightFax client software and identify a user or extension on the fax server for use with Kofax Message Connector.

Configure RightFax server

1. On the RightFax fax server, start the **Enterprise Fax Manager** tool.
2. Create (or reserve) a user or extension for use with Kofax Message Connector.
3. Close the tool.

Install RightFax client

1. On the Message Connector computer, start the **RightFax Product Suite** setup.
2. When prompted to select the setup type, select **Typical Client**.
3. In the **RightFax Server Name** box, enter IP address or name of the fax server.
4. Click **Install**.
5. On the Windows Start menu, start **RightFax FaxUtil**.
6. Enter the logon information.
Keep the **Remember password** check box clear.
7. Click **OK**.
Upon logon, the RightFax FaxUtil window opens.

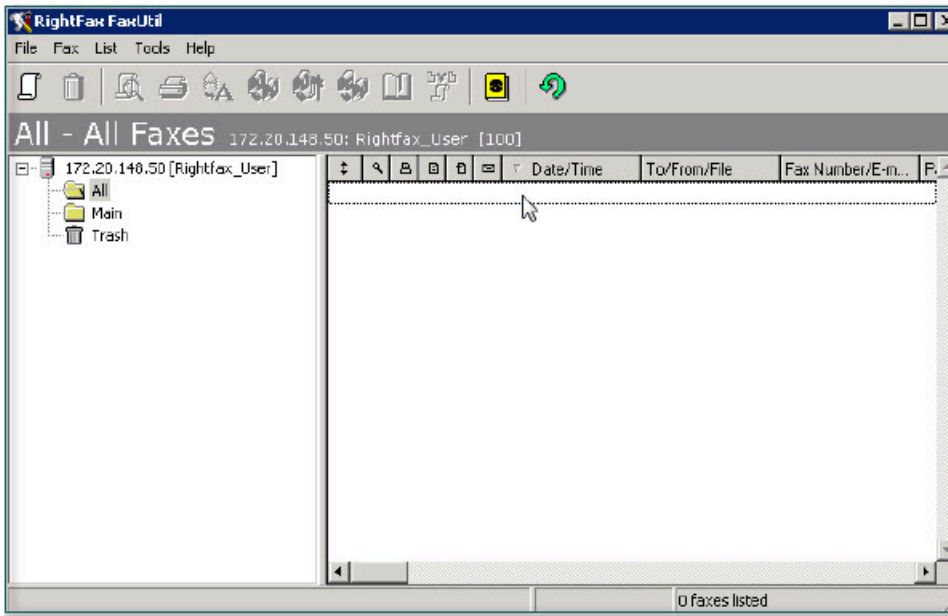

8. Close the client.

Forward faxes from multiple mailboxes to a single queue user

In Kofax TotalAgility, you can configure a single user for accessing RightFax. An administrator can have access to multiple mailboxes. If you do not want to use the administrator user for security reasons, consider setting up fax forwarding to a dedicated user, and use the credentials of this dedicated user in Kofax TotalAgility. Each fax user must configure fax forwarding using RightFax FaxUtil.

1. Start **RightFax FaxUtil** from the Windows Start menu and log on.
2. On the **Tools** menu, click **Options**.
3. On the **Receiving** tab, select **Forward Received Faxes to User**.
4. Select the dedicated user as the recipient of the forwarded faxes.
5. Confirm the changes and close FaxUtil.

Keep messages on RightFax server

By default, Kofax Message Connector deletes imported messages from the fax server. You can configure Message Connector to keep the messages on the fax server for processing later.

1. Navigate to the `MC\config` folder and open `SolutionConfig.xml` in an editor.
2. Add the following content between the `</SSL>` and `<CallPeerList>` lines:

```
<FaxServer>
<RFaxKeepMsgs>2</RFaxKeepMsgs>
</FaxServer>
```

3. Save and close the file.

Message Connector configuration now contains a new tab Fax Server with a single parameter "Keep messages on RightFax Server" set to "[2] yes".

4. Start Message Connector configuration. Verify the value in the Fax Server tab.
5. Click **Save** and then click **Exit**.

Imported messages are no longer deleted from the RightFax server; instead, the text "KCFax:marked to delete" is added to the comment field and the flag FAXFLAG_GENERIC2 is set.

Connect to RightFax fax server - Rest Web API

In addition to configuring the connection to the RightFax fax server in TotalAgility Designer, the RightFax Web API interface must be installed and enabled on the RightFax server to use with Kofax TotalAgility.



- You can poll fax server with only one Message Connector. Running multiple Message Connectors in parallel may import the same fax multiple times in TotalAgility.
- RightFax client installation is not necessary on the Message Connector computer.

Work with your fax server administrator to complete the tasks described in the following sections.

Prerequisites

RightFax server version 16.4 or higher to support the Rest Web API for the clients.



From the RightFax server version 16.6 and higher, support for the traditional COM API is discontinued.

Configure RightFax server

The RightFax Web API interface must be explicitly installed/enabled on the RightFax server.



The HTTP verbs GET, POST, PUT and DELETE must be allowed on IIS on the RightFax server. However, PUT and DELETE may be disallowed on IIS.

1. On the RightFax fax server, start the Enterprise Fax Manager tool.
2. Create (or reserve) a user or extension for use with TotalAgility.
3. Close the tool.
4. Optional. Verify the connection through Rest Web API to the RightFax server with the FaxUtil Web client of OpenText, which uses the same API as the Message Connector. Therefore, if you cannot access the RightFax server mailbox, the Rightfax Connector will also not work. Do the following:
 - a. Execute the following URL in a browser on a computer where Message Connector is installed:
`http://<RightFaxServer>/rightfax`
where, <RightFaxServer> is the IP address or hostname of the RightFax server.

- b. Click **FaxUtil Web** and log in with any RightFax user. Verify if you can access the mailbox.

i If you cannot access RightFax server with FaxUtil Web using the steps above, contact your RightFax server administrator.

Configure RightFax connector in TotalAgility

The following configurations are specific for the RightFax Rest Web API fax server type. For complete fax server settings, refer to the *Kofax TotalAgility Help*.

1. In TotalAgility Designer, navigate to **Integration > Import settings**.
The **Import settings** page appears.
2. Click **New** or an existing import connection.
The **New import connection** or **Update import connection** page appears.
3. Under the **Import sources** table, click +.
The **New import source** dialog box is displayed.
4. On the **General** tab, select **External fax server**.
5. Select **Fax users to monitor** tab and on the **Fax server type** list, select **RightFax Rest WebAPI**.
6. In **Host**, specify the fax server URL in the following format: `http[s]://<RightFaxServer>/rightfax/api`
where, `<RightFaxServer>` is the IP address or hostname of the RightFax server.
7. Under **Operation mode**, select whether to poll the fax server using single or multiple Message Connectors. See the next section.

Single instance and multi-instance modes

When configuring RightFax server in TotalAgility, you can select to poll the RightFax server using one or multiple instances of Message Connector.

Single instance

Allows polling of fax server with only one Message Connector. Selecting this option and running multiple connections in parallel may import the same fax multiple times in TotalAgility.

The process of importing a message is as follows:

1. When a new fax is detected in the fax server inbox, it is immediately imported into Message Connector storage. The comment field for the message in the RightFax server inbox displays the following status:

```
[<UniqueId>]KCFax: fetched at <Date and Time>, awaitConfirm for 600s
```

where,

<UniqueId>: The unique ID of Message Connector which is polling the fax server.

<Date and Time>: The UTC date and time when the message arrived in ISO 8601 format.

2. Once the message is imported in TotalAgility, the comment field of the message in the RightFax server inbox is updated with the following status:

```
[<UniqueId>]KCFax: deleted at <Date and Time>
```

3. The message is deleted immediately.

Multi-instance

Allows multiple Message Connector connections to a single fax server, without risking duplicate imports. However, to avoid duplicate fax import, this option introduces a small delay in importing faxes (by default, 60 seconds).

When a new fax arrives in the fax server inbox, instead of importing this message immediately, all Message Connector instances attempt to reserve the message. But the message is reserved for only one instance of Message Connector and only that instance can fetch the message.

The process of importing a message is as follows:

1. When a new fax is detected in the fax server inbox, this message is reserved for a specific instance of Message Connector. Before importing, this message must wait in the inbox for 60 seconds (ReservationTimeout).

The comment field for the message in RightFax server inbox displays the following status:

```
[<UniqueId>]KCFax:reserved at <Date and Time>,awaitFetch for 60s  
where,
```

<UniqueId>: The unique ID of Message Connector which is polling the fax server.

<Date and Time>: The UTC date and time when the message arrived in ISO 8601 format .

2. Once 60 seconds (ReservationTimeout) are expired, the message is immediately imported into Message Connector storage. The comment field for the message in RightFax server inbox displays the following status:

```
[<UniqueId>]KCFax:fetched at <Date and Time>,awaitConfirm for 600s
```

3. When the message is imported to TotalAgility, the comment field for the message in RightFax server inbox is updated with the following status:

```
[<UniqueId>]KCFax:deleted at <Date and Time>
```

4. The message is deleted immediately.

If a message reserved for a specific Message Connector is not polled due to reasons such as the specific Message Connector instance is not working, the following process is used:

1. The message remains in the reserve state for ProcessingTimeout (by default, 3600 seconds).
2. Once the ProcessingTimeout is expired, the message enters and remains in the expiration pending state define by ExpiryTimeout (by default 300 seconds).
3. Once the ExpiryTimeout is expired, the message can be reserved by any running instance of Message Connector and is treated as a new message.

 To compensate ReservationTimeout (60 seconds) for every message, each Message Connector instance can reserve up to 100 messages (MaxReservedTotal) and keep polling the messages for which the ReservationTimeout is expired.

By default, all configuration values are defined for optimum performance. If required, change the values of these parameters in the Create_Config.xml file.

Parameter name	Default value	Description
ReservationTimeout	60 seconds	The time for which message remains in reserved state.
ProcessingTimeout	3600 seconds	The time limit for processing a message once the reserve timer is expired.
MaxReservedTotal	100	Maximum number of messages a single instance of Message Connector can reserve.
ExpiryTimeout	300 seconds	The time limit to wait after ProcessingTimeout. Once this expires, the message is handled as a new message.

Forward faxes from multiple mailboxes to a single queue user

In TotalAgility, you can only configure a single user for accessing RightFax. You can access multiple mailboxes using an administrator user. If you do not want to use an administrator user for security reasons, you can set up fax forwarding to a dedicated user, and use the credentials of this user in TotalAgility. Each fax user must configure fax forwarding using RightFax FaxUtil.

1. Start RightFax FaxUtil from the Windows Start menu and log in.
2. On the **Tools** menu, click **Options**.
3. On the **Receiving** tab, select **Forward Received Faxes to Users**.
4. Select the dedicated user as the recipient of the forwarded faxes.
5. Confirm the changes and close FaxUtil.

Keep messages on RightFax server

By default, TotalAgility deletes the messages imported from the fax server. You can configure Message Connector to keep the messages on the fax server for later processing. Do the following in Message Connector Configuration:

1. Set **Keep messages on RightFax server** of the **Fax server** tab to **[8] Yes (for RightFax/REST)**.
2. Start Message Connector Configuration. Verify the value in the **Fax server** tab.
3. Click **Save** and then click **Exit**.

Imported messages are no longer deleted from the RightFax server, instead, the text "KCFax:marked to delete" is added to the comment field.

Poll order

The following improvements are implemented in the RightFax connector to avoid situations where some faxes may stay much longer in the inbox than the others.

RightFax connector - Web API	RightFax connector - COM API
Retrieves the oldest fax from the inbox first.	Retrieves the newest fax first, causing the older faxes to remain in the inbox longer.
Polls multiple inboxes in a round-robin manner.	Starts the poll cycle with the first user in the list and only serves the others if first user's inbox is empty.

Security and authentication

- RightFax supports only basic authentication for the Rest Web API. Refer to the API help at: <http://rightfaxsdk.cloudapp.net/RightFaxSdk/ApiHelp/default.htm>
- For security purposes in production environments, an SSL certificate would be installed on the IIS server and on the RightFax server, and the RightFax and the RightFax connector would use the https type of connection.
- In test environments, there may be only a self-signed SSL certificate installed on the server, and the RightFax connector will not be able to connect through an HTTPS connection, as it may not trust the certificate. To ignore certificate errors in test environments, do the following:

1. Open Create_Config.xslt in a text editor. Default path:
C:\Program Files (x86)\Kofax\KIC-ED\MC\xcd
2. Set the value of <IgnoreCertificateError> element to true as shown below.

```
<TncRFax2>
...
<Test>
  <IgnoreCertificateError>true</IgnoreCertificateError>
</Test>
...
</TncRFax2>
```

3. Save and close the file.
4. Run configure.bat.

Troubleshoot Rest Web API connection issues

To troubleshoot Rest Web API connection issues, use the Fiddler tool. Refer to the following link: <https://www.telerik.com/download/fiddler>

i The Fiddler tool cannot log the Web API communications for Windows services; therefore, enable logging in the Message Connector configuration.

1. Open Create_Config.xslt in a text editor. Default path:
C:\Program Files (x86)\Kofax\KIC-ED\MC\xcd
2. Search for the following code snippet.

```
...
  <Proxy>
    <!-- set enabled to true only to log the webAPI traffic with fiddler -->
    <Enabled>true</Enabled>
    <Url>http://localhost:8888</Url>
    <BypassOnLocal>true</BypassOnLocal>
  </Proxy>
...

```

3. Change the value of the <Enabled> element from false to true.
4. Save and close the file.
5. Run configure.bat.
6. Save the Message Connector configuration and restart the Message Connector service.

7. Start Fiddler and enable the logging of traffic to the IP address of the RightFaxServer.

 In Fiddler enabled mode, Fiddler must be running for the Message Connector to work.

Alternatively, stop the Message Connector service, and start it in the command line mode by executing the run.bat file. When running in the command line mode, Message Connector is automatically traceable by Fiddler.

Once Fiddler is running and tracing the communication between Message Connector and RightFax server, run the functions with issues and then save the session data collected in Fiddler for further analysis.

Connect to Kofax Communication Server

In addition to configuring the connection to the Kofax Communication Server in TotalAgility Designer, identify a user or extension on the fax server for use with Kofax Message Connector.

 For an external fax server, when you send an email with an attachment using Kofax Communication Server as a fax server type, TotalAgility only imports the email attachment and cannot create a document for the email body. See *Kofax TotalAgility Help*.

1. On the Kofax Communication Server system, start the **TCfW Communication Server Client**.
2. Create (or reserve) a user or extension for use with Kofax Message Connector.
3. Optionally, if you want to import faxes received by multiple Kofax Communication Server users, set up fax forwarding for each user and forward the faxes to the created user.
4. Close the client.

Import PST files

Personal storage table (PST) files are used by Microsoft Outlook and other Microsoft products to store messages and other items. Use the following procedure to extract all messages from a PST file to a folder. Kofax Message Connector can then import the extracted messages to Kofax TotalAgility.

1. Open a Windows Command Prompt in the Message Connector installation folder. The default location (for 64-bit operating system) is:

```
C:\Program Files (x86)\Kofax\KIC-ED\MC\bin\KFXConverter
```

2. Run the following command:

```
KFXConverter.exe -s <sourcepath>\<filename> -f <destinationpath>\ -type msg
```

3. Configure the following details:

- a. For <source path>, enter the folder where your PST is located.
- b. For <filename>, enter the name of the PST file to be imported.
- c. For <destination>, enter the folder where the MSG files should be extracted.

4. Once extraction is complete, move the extracted files to a watched folder to import them to Kofax TotalAgility.



- You cannot import the MSG files where attachments have been removed by any Microsoft Outlook archive tool.
- You can import multiple PST files simultaneously. However, when you run multiple KFXConverter instances in parallel, some information about the second and later instances might be missing from the log file. To ensure that your logs are complete, you can specify different log files for each instance using the command line switch: `-logfile <logfile name>`

PDF normalization

When you select to normalize your message content to PDF, Kofax Message Connector normalizes all non-PDF parts of the message to an ISO-standardized version of PDF, the PDF/A. However, Message Connector can also normalize PDF parts to PDF/A.



- If Microsoft Office is selected as normalization tool in **MS Office and selected Open Office documents**, normalization of Excel documents result in PDF documents rather than PDF/A documents.
- Any embedded macros in Microsoft Office documents are ignored during document normalization.

Configure PDF variant

You can select one of several supported PDF variants by editing a batch file.

1. Open the folder `C:\Program Files (x86)\Kofax\KIC-ED\MC\Scripts` (assuming default installation path on a 64-bit operating system).
2. Edit the file `KFXConverter.bat` in a text editor.
3. Configure the type of PDF produced when converting non-PDF documents to PDF:



This step is required if you are using Kofax Converter for the normalization. If you are using a different converter, such as Microsoft Office, this setting does not modify the converted PDF type.

- a. Find the string `IF %ConvertToType%== "PDF/A" (.`
- b. Edit the line immediately below `set ConvertToType="PDF/A1B"`. The following values are supported:
 - PDF
 - PDF/A1A
 - PDF/A1B (default)
 - PDF/A2B

4. Configure the type of PDF produced when normalizing existing PDF documents:
 - a. Find the string `IF %ConvertToType%== "PDFAn" (.`
 - b. Edit the line immediately below `set ConvertToType="PDFA1BN"`. The following values are supported:
 - PDF (disables PDF normalization)
 - PDFA1AN
 - PDFA1BN (default)
 - PDFA2BN
5. Save the file and close it.

Configure document normalization

Kofax Message Connector can normalize text, HTML, OpenOffice.org, and Microsoft Office documents to PDF. The images are not normalized to PDF, but they are always imported in their original format.

1. Start Message Connector Configuration from the Kofax group in the Windows Start menu.
2. Expand the **Document conversion** tab.
3. If you want to extract documents from compressed files, select **Unpack archives**. The following formats/extensions are supported: zip, rar, 7z, tar, gzip. Extraction happens before document normalization; that is, a Word document extracted from a .zip file can be further normalized into PDF. Extraction is repeated if the extracted file is another compressed file (such as .zip within a .zip) until all compressed files are extracted. A .zip file containing multiple files with the same name is also extracted. The following restrictions apply:
 - Password-protected compressed files are not extracted.
 - Archives split to multiple volumes are not supported.
 - EML documents from compressed files are not subject to further extraction/document normalization.
 - If the extraction ends without an error, the compressed file is discarded. When archiving to folder is enabled, the extracted files are archived, not the compressed ones.
4. Select the tool for converting Microsoft Office documents.
5. Select the tool for converting HTML documents.
6. If you selected **Open/Libre Office** in step 3, make sure that you have installed the necessary extension. See [Third-Party software](#).
7. If you selected **Microsoft Office** in either step 3 or step 4, and you are using the operating system Windows Server 2012, Windows 10, or later, you need to select the Windows user account to be used for Microsoft Office DCOM automation. For initial tests and troubleshooting, you may use the interactive user. For production use, you must specify an administrator user.
8. Click **Advanced**. In the **Security options** tab, verify that document conversion is not disabled.
9. Click **Save**. Click **Exit and restart service**.

For input and output formats supported by Message Connector for document normalization, see **Appendix H: Supported input and output formats**.

Configure Microsoft Office

Message Connector can use Microsoft Office for document normalization.

- Install a supported version of Microsoft Office on the same computer as Message Connector.
- Make sure that at least one printer is installed (required for Microsoft Excel document conversion).
- Start all applications (Word, Excel, PowerPoint) at least once and respond to the initial prompts.
- If you are using 64-bit version of Microsoft Office, create the folder `C:\Windows\System32\config\systemprofile\Desktop`.

 Customers are responsible for providing appropriate licenses for third-party software.

Configure OpenOffice.org / LibreOffice extension

Kofax Message Connector supports the normalization of Microsoft Office documents using Microsoft Office, LibreOffice or OpenOffice.org.

If using LibreOffice / OpenOffice, you must install the supported version of the LibreOffice / OpenOffice extension on the same computer where Message Connector is installed. Before installing, shut down all OpenOffice / LibreOffice processes (including Quickstarter).

1. Install a supported version of OpenOffice.org. Refer to [Third-Party software](#) for supported versions.
2. Shut down all OpenOffice.org processes (including Quickstarter).
3. From the installation media, browse to the `TotalAgility\KIC\Export\MC\OpenOfficeExtension` folder and start **setup.exe**.
4. Click **Browse**. Windows explorer displays the content of the installation folder.
5. Go to the folder `MC\OpenOfficeExtension` and start **Install.bat**.
This identifies the installed applications on the system and then installs the applicable extensions. If more than one application is installed, the following priority order is used to identify the application for which the extension will be installed: LibreOffice > ApacheOpenOffice > OpenOffice.org.
6. Wait until the extension is installed.

You can manage installed OpenOffice.org extensions by selecting **Tools > Extension Manager** from any OpenOffice.org application menu. The extension list should include "Kofax Conversion for OpenOffice 1.0." A properly installed extension has the symbol  indicating that this extension is installed for all users.

Configure Total HTML ConverterX

Message Connector can use Total HTML ConverterX for converting HTML documents, such as email messages in HTML format. Note the following:

- Download the software from <http://www.coolutils.com/TotalHTMLConverterX>. You can start with the trial version for initial testing.

- Install Total HTML ConverterX on the same computer as Message Connector. Use the default installation path.

 Customers are responsible for providing appropriate licenses for third-party software.

Third-Party software

The following information applies to third-party software:

- Customers are responsible for providing appropriate licenses for third-party software.
- Install third-party software to the default installation path.
- Install the following third-party application versions as required:
 - For normalizing Microsoft Office files, you can use the internal conversion tool (KFXConverter) or install one of the following:
 - Apache OpenOffice (certified version 4.1.7)
 - LibreOffice 6.4 (32-bit)
 - Microsoft Office 365
 - Microsoft Office 2016
 - Microsoft Office 2013
 - Microsoft Office 2010
 - For normalizing HTML files, you can use the internal conversion tool (KFXConverter) or install one of the following:
 - Microsoft Office 365
 - Microsoft Office 2016
 - Microsoft Office 2013
 - Microsoft Office 2010
 - Total HTML ConverterX
 - For normalizing Open Office files (ODT, ODS and ODP formats), you can use the internal conversion tool, KFXConverter. For normalizing other Open Office document formats, use OpenOffice.org.

- 
- Do not install OpenOffice.org/LibreOffice and Microsoft Office 2013 on the same computer, as document normalization using Microsoft Office 2013 may fail.
 - Use Internet Explorer to access Message Connector user interface and document conversion configuration utilities.
 - Third-party software such as Microsoft Office requires the appropriate licenses, which are not included in the Message Connector license.

Configure Kofax Converter

Configure the advanced settings of the Kofax Converter (KfxConverter) by editing the KFXConverter.ini file in a text editor. The ini file is located in the same folder as the Kofax Converter executable. The default location:

C:\Program Files (x86)\Kofax\KIC-ED\MC\bin\KFXConverter\.

Message Connector installs the KFXConverter_Default.ini file to the same folder. If the KFXConverter.ini does not exist when Message Connector starts, a copy of KFXConverter_Default.ini is created. An existing KFXConverter.ini is not modified by the setup.

The following parameters are available:

 Fix the line breaks if you copy and paste the parameters from this guide.

Group	Parameter name	Default value	Description
EML2PDF	EnableMargin	False	If set to True, KfxConverter considers the margin parameters and the parameter PgNmDistFromHeader.
	LeftMargin	3.175 cm	Left margin of page (in centimeters).
	RightMargin	3.175 cm	Right margin of page (in centimeters).
	TopMargin	2.54 cm	Top margin of page (in centimeters).
	BottomMargin	2.54 cm	Bottom margin of page (in centimeters).
	PgNmDistFromHeader	1.3 cm	Page number distance from header (in centimeters).
	EnableFontSize	False	If set to True, KfxConverter considers the "FontSize" parameter, and all the converted PDF files will be the same font size.
	FontSize	12	Font size in points.
	DateFormat		<p>Defines the date format. If empty, the default date format is used. Examples:</p> <ul style="list-style-type: none"> DateFormat="dd-MMM-yy" DateFormat="yyyy-MM-dd" <p>For more information, see http://msdn.microsoft.com/library/8kb3ddd4(v=vs.110).aspx</p> <p> Depending on the regional settings of your operating system, certain separators are not available. For example, a forward slash configured in the .ini file might be replaced with a hyphen as date separator.</p>
FitTableWidthToPage	True	<p>Resize the table width in an output PDF file when converting EML files (including body with message header).</p> <p>If set to true, KFXConverter sets the table width based on the page size in output PDF files.</p>	

Group	Parameter name	Default value	Description
	ResizeLargeImages	2	<p>Resize the images that are larger in size. The following options are available:</p> <p>0 - Image is not resized.</p> <p>1 - The image size is compared with the section size of the document. If the image size is larger than the section size, image is resized to fit the section.</p> <p>2 - Free space is calculated based on whether an image is inline or floating. The image resize ratio to fit the page size is calculated as per the longer side of the image, and then the image is resized.</p> <p>i If ResizeLargeImages is set to 0 when the input file contains large size images, file conversion may result in data loss.</p>
PDF2PDF	ALCWebServiceTimeout	1200 sec	Adobe Experience Manager web service timeout in seconds.
TEXT2PDF	FontType	Arial Unicode MS	Specifies the font type for the generated PDF. The font must be installed on the computer on which KFXConverter is used.
EXCEL2PDF	FitAllColumnsToOnePage	True	If set to True, all the columns are set to one page.
	PaperOrientation	-1	Defines the paper orientation. Default is -1, for Landscape 0, for Portrait 1
	PaperSize	Default	Disables the papersize setting.
	ConvertSheets	All	<p>KFXConverter converts the pages according to the values specified in field. Possible values are: All, Active, 1, 2, 3 and so on. Specify the values as comma-separated values.</p> <p>For example, ConvertSheets=Active,1 converts the first page and the active page, whereas ConvertSheets=All converts all the pages.</p> <p>i If a blank page is selected for conversion and no printable area is selected in Excel, KFXConverter ignores this page at the time of conversion. But, if a blank page with a defined printable area is selected for conversion, KFXConverter converts this page into a PDF.</p>
	EnableMargin	False	If set to True, KFXConverter considers the margin parameters.
	LeftMargin	1	Left margin of page (in centimeters).

Group	Parameter name	Default value	Description
	RightMargin	1	Right margin of page (in centimeters).
	TopMargin	1	Top margin of page (in centimeters).
	BottomMargin	1	Bottom margin of page (in centimeters).
HTML2PDF	EnableMargin	False	If set to True, KFXConverter considers the margin parameters for HTML2PDF files.
	LeftMargin	0.3528 cm	Left margin of page (in centimeters).
	RightMargin	0.3528 cm	Right margin of page (in centimeters).
	TopMargin	2.54 cm	Top margin of page (in centimeters).
	BottomMargin	2.54 cm	Bottom margin of page (in centimeters).
MHT2PDF	EnableMargin	False	If set to True, KFXConverter considers the margin parameters for MHT2PDF files.
	LeftMargin	3.175 cm	Left margin of page (in centimeters).
	RightMargin	3.175 cm	Right margin of page (in centimeters).
	TopMargin	2.54 cm	Top margin of page (in centimeters).
	BottomMargin	2.54 cm	Bottom margin of page (in centimeters).
EXTERNAL RESOURCE LOADING	LoadExternalResources	True	If set to False, when converting EML or MSG documents, KFXConverter does not download any externally linked resource, for example, an image from an Internet hyperlink.
GENERAL	OriginalDocumentFolder		If document conversion fails and path is valid, original file is saved at this path.
	EnablePageHeader	True	If set to False, KFXConverter disables the page number displayed on top of each page.
	EncodingType	UTF-8	If encoding type is defined in the input files, KFXConverter uses the same for converting the documents; otherwise, the default encoding type or the value specified for the EncodingType parameter is used. The encoding type is only applicable for HTML, MHT and EML file formats.
	DebugLog	False	If set to True, KFXConverter logs additional trace statements in the KFXConverter.log file in case of errors or exceptions. See Manage logs in KFXConverter .

Group	Parameter name	Default value	Description																						
PDF2PDF/A	AllowedErrors	128	<p>If the Standard (Recommended) option is selected for the PDF to PDF/A conversion engine field in Message Connector, the KFXConverter allows the document conversion with the specific conversion errors.</p> <p>To ignore one or more conversion errors and allow conversion, set the value of AllowedErrors to one error code or to a combination of error codes.</p> <p>If AllowedErrors=0, no error is allowed. All the error codes and all possible values generating from an OR operation of the error codes can be used to ignore one or more document conversion errors.</p> <p>The following table lists the error codes and description.</p> <table border="1" data-bbox="907 863 1463 1514"> <thead> <tr> <th data-bbox="907 863 1057 909">Error code</th> <th data-bbox="1057 863 1463 909">Description</th> </tr> </thead> <tbody> <tr> <td data-bbox="907 909 1057 955">4</td> <td data-bbox="1057 909 1463 955">Visual differences</td> </tr> <tr> <td data-bbox="907 955 1057 1001">8</td> <td data-bbox="1057 955 1463 1001">Name collisions of colorants</td> </tr> <tr> <td data-bbox="907 1001 1057 1077">16</td> <td data-bbox="1057 1001 1463 1077">Removing optional content groups (layers)</td> </tr> <tr> <td data-bbox="907 1077 1057 1123">32</td> <td data-bbox="1057 1077 1463 1123">Removing transparency</td> </tr> <tr> <td data-bbox="907 1123 1057 1169">64</td> <td data-bbox="1057 1123 1463 1169">Removing embedded files</td> </tr> <tr> <td data-bbox="907 1169 1057 1245">128</td> <td data-bbox="1057 1169 1463 1245">Removing non-convertible XMP metadata</td> </tr> <tr> <td data-bbox="907 1245 1057 1320">512</td> <td data-bbox="1057 1245 1463 1320">Removing of signatures while normalizing the signed document</td> </tr> <tr> <td data-bbox="907 1320 1057 1396">4096</td> <td data-bbox="1057 1320 1463 1396">Normalizing corrupt input document</td> </tr> <tr> <td data-bbox="907 1396 1057 1442">16384</td> <td data-bbox="1057 1396 1463 1442">Similar font substitution</td> </tr> <tr> <td data-bbox="907 1442 1057 1514">32768</td> <td data-bbox="1057 1442 1463 1514">Removing interactive elements such as actions or annotations</td> </tr> </tbody> </table> <p>Examples:</p> <ul style="list-style-type: none"> • If AllowedErrors = 4, visual differences in the output file do not cause a document conversion error. • If AllowedErrors = 132, that is, combination of error code 4 and error code 128, conversion is done even if there are visual differences in the output file, or non-convertible XMP metadata is removed. 	Error code	Description	4	Visual differences	8	Name collisions of colorants	16	Removing optional content groups (layers)	32	Removing transparency	64	Removing embedded files	128	Removing non-convertible XMP metadata	512	Removing of signatures while normalizing the signed document	4096	Normalizing corrupt input document	16384	Similar font substitution	32768	Removing interactive elements such as actions or annotations
Error code	Description																								
4	Visual differences																								
8	Name collisions of colorants																								
16	Removing optional content groups (layers)																								
32	Removing transparency																								
64	Removing embedded files																								
128	Removing non-convertible XMP metadata																								
512	Removing of signatures while normalizing the signed document																								
4096	Normalizing corrupt input document																								
16384	Similar font substitution																								
32768	Removing interactive elements such as actions or annotations																								
SKIPCONVERSION	InputPDFhasAttachments	False	If set to True, the conversion of an input PDF file is skipped if it contains attachments.																						

Group	Parameter name	Default value	Description
	InputPDFhasUnknownFonts	False	If set to True, the conversion of an input PDF file is skipped if it contains unknown fonts.
	InputPDFisaValidPDFA	False	If set to True, the conversion of an input PDF file is skipped if it is a valid PDF/A document.
	InputPDFisSigned	False	If set to True, the conversion of an input PDF file is skipped if it is signed.

Date/Time format

By default, the Date/Time metadata fields always return values in the UTC format. You can configure Date/Time metadata fields to return values in the local system format. Do the following for each Core Worker:

1. Open the following file in a text editor

```
C:\Program Files\Kofax\TotalAgility\CoreWorkerService
\Agility.Server.Core.WorkerService.exe.config
```

2. Search for the `IsUtcTime` parameter and set its value to false as shown below:

```
<add key="IsUtcTime" value="false" />
```

i If you already set the value of `IsUtcTime` to false and want to view the date/time values in the UTC format, set its value to true.

3. Save and close the file.

Import MSG and EML files from folder

When you import MSG and EML files from a folder, these email messages are treated as received emails. The metadata, such as subject, to, from, date, are extracted directly from the email message. All content selection and conversion options, such as converting to TIFF, adding a message header, importing only body or attachments, apply to the MSG or EML file.

i If you are not importing MSG and EML files from a folder directly, but are using a controlling XML file which links these email documents, only the email body is converted and imported. The attachments are discarded, unless you select the "Extract referenced MSG/EML files" option in TotalAgility Designer.

Note the following points for the EML and MSG files import:

- When a single EML or MSG file is imported and the **Import trigger file** option is not selected, TotalAgility treats the EML/MSG file as a received mail and keeps the metadata of the email message and not the metadata of the file on disk storage.
- When a single EML or MSG file is imported and the **File not modified since** option is selected, TotalAgility treats the EML/MSG file as a received mail and keeps the metadata of the email message and not the metadata of the file on disk storage.
- When a single EML or MSG file is imported and the **Import trigger file** option is selected, TotalAgility only keeps the metadata of the file on disk storage.

- When two or more EML or MSG files are imported using the trigger file, TotalAgility always keeps the metadata of the file on disk storage.

Import XFA files

You can import and normalize the PDF documents with Adobe XML Forms Architecture (XFA forms) using the Message Connector. To achieve this, Adobe Experience Manager Server is required.

 If support for Adobe LiveCycle is available, you can also use Adobe LiveCycle for conversion of XFA Forms.

Following are the prerequisites for using Adobe Experience Manager Server:

- You must install and configure the Adobe Experience Manager Server to make it accessible to TotalAgility. The Output service must be running, and its web service must be enabled and working properly.
- Adobe Experience Manager software must be installed on a different computer than TotalAgility. However, to decrease the probability of timeouts and retries, we recommend that you install the software in the same network LAN segment.
- The minimum supported version of Adobe Experience Manager Server is 6.3.
- You must acquire the Adobe Experience Manager product through an appropriate Adobe Sales Channel. Kofax does not ship, install, support or troubleshoot the Adobe Experience Manager Server. The customer using this feature is responsible for any licensing requirements and maintenance contract and/or agreements required by Adobe, and any of third-party vendor that may be involved.

 Any limitations imposed by Adobe are applicable. For example, only XFA PDFs with no rights, signature, or certification can be converted to PDF or PDF/A. Refer Adobe Experience Manager documentation for more information.

- When an exception occurs while using Adobe Experience Manager, TotalAgility reports the exception in its log file, and the error is treated as a standard document conversion error.

To configure the Adobe Experience Manager Server, do the following:

- In Message Connector, specify the information for connecting to Adobe Experience Manager Server on the **Adobe Experience Manager** tab.
- In the Integration module of TotalAgility Designer, enable the **Flatten XFA forms to PDF documents using Adobe Experience Manager** setting when configuring the import source settings.

 Enabling this setting may have impact on the performance as each PDF document is sent to document converter to determine whether it is XFA form or standard PDF.

- For more information on the import source settings, see the *Kofax TotalAgility Help*.

Archive documents

TotalAgility can archive processed documents. You can configure the archive folder, file formats and file name prefixes for the following type of archived documents:

- Successfully imported
- Partially imported
- Rejected or failed

For more details, see the *Kofax TotalAgility Help*.

If you are upgrading TotalAgility from version 7.8.0 or lower, note the following:

- **Archive folder:** Populated with the value configured in the previous version.
- **Subfolders and file prefix:** Populated with the following values:
 - **{OK}\{Timestamp(YYYYMMDDhhmmss)}_{Message-ID}**: For successfully imported
 - **{PARTIAL}\{Timestamp(YYYYMMDDhhmmss)}_{Message-ID}**: For partially imported
 - **{REJECT}\{Timestamp(YYYYMMDDhhmmss)}_{Message-ID}**: For rejected or failed
- **Format:** All formats will be selected for successfully imported, partially imported and rejected/failed sections.

Configure SSL connection

Using SSL connections, configure TotalAgility to operate in a secure environment.

1. Create an SSL certificate for each component that you want to connect securely. Use the following tools:
 - Microsoft Active Directory Certificate Services
 - OpenSSL
2. Configure each component that you want to connect securely:
 - For Message Connector, convert the certificate to .pem format so that you can copy the private key and the certificate to the Configuration Utility.
 - For TotalAgility, install the certificate using Microsoft Management Console (MMC) local account and copy the thumb print to the Configuration Utility.
3. Install the certificates on all computers that connect to a secure server.

See [Request a certificate for Message Connector using Microsoft Active Directory Certificate Services](#) for an example.

Secure connection between Message Connector and TotalAgility

1. In the Message Connector Configuration, click **Advanced** to display additional configuration options.
2. On the **HTTP** tab, select **SSL/TLS active** to enable SSL.
3. On the **SSL/TLS certificate** tab, edit the fields as needed. For production use, update the **SSL/TLS certificate** field.

4. In the Integration module of TotalAgility Designer, enable the **Flatten XFA forms to PDF documents using Adobe Experience Manager** setting when configuring the import source settings.
5. Click **Test connection** to verify the connection.

Secure connection for incoming SMTP mail

1. In the Message Connector Configuration, click the **Email inbound via SMTP** tab.
2. On the **SSL/TLS active** list, select **ONREQUEST** or **ALWAYS** to activate the SSL protocol.
3. On the **SSL/TLS certificate** tab, edit the fields as needed.

Secure connection for outgoing SMTP mail

In Message Connector Configuration, on the **Email outbound** tab, select **ONREQUEST** or **ALWAYS** on the **SSL/TLS active** field.

Secure connection for POP3/IMAP mail

1. In the Integration module of TotalAgility Designer, edit the connection for a POP3/IMAP type of import source.
2. Select **Always** or **Negotiate** for **SSL**.

Secure connection for Exchange Web Services

1. In the Integration module of TotalAgility Designer, specify the EWS **URL** when configuring the import source settings.
2. The prefix of the EWS URL in the field determines whether the connection is secure. Use **https** for secure connections.

Request a certificate for Message Connector using Microsoft Active Directory Certificate Services

This example explains how to use Microsoft Active Directory Certificate Services to generate a certificate for Message Connector and OpenSSL to extract the private key and certificate. The following requirements and additional information:

- Requirement for Microsoft Certification Services:
 - Configure the server for https binding ([https://\[CANAME\]/certsrv/](https://[CANAME]/certsrv/)).
 - Configure the server to archive the key.
 - Create a template which allows to export the private key.
 - OpenSSL
 - To export a decrypted private key.
 - To create a PKCS#12 file.
1. Use Microsoft Certification Services to request a certificate.
 - a. Use a web browser to connect to the CA Server (<https://CANAME/certsrv/>).
 - b. Select **Request a certificate**.
 - c. Select **Advanced certificate request**.

- d. Select **Create and submit a request to this CA**.
 - e. Fill out the necessary information in the form, and select the correct Certificate Template.
 - f. Select **Mark keys as exportable**. Enter the Message Connector server name in the **Name** box.
 - g. Click **Submit**. Wait until the certificate is issued.
 - h. Click **Install this certificate**. Wait until the certificate is installed.
2. Use a web browser to export the certificate.
 - a. Go to Tools > Internet Options > Content > Certificates.
 - b. On the **Personal** tab, select the certificate and click **Export**.
 - c. Select to export the private key. Select **PKCS #12** as the format.
 - d. Type a password to protect the key.
 - e. Specify the location and file name, and click **Finish**.
3. Use OpenSSL to extract the private key and the certificate to .pem format. For example:

```
openssl.exe pkcs12 -in "c:\certif.pfx" -out  
"c:\certif.pem" -nodes
```

Provide the password used in Step 2.
4. Open the pem file in a text editor. The certificate and private key for configuring Message Connector are available in this file. See [Configure SSL connection](#).

Filter source IP addresses for SMTP connections

Define filters in Message Connector to provide additional security. Use filters to allow SMTP connection requests from authentic IP addresses, and to avoid or reject requests from unsolicited IP addresses.

 Filters are only applicable for requests from SMTP connections; requests from other connection types such as HTTP are not filtered.

Message Connector Configuration provides an option to define a list of filters in the **Source IP filter** field of **Email inbound via SMTP** tab. Using these filters, SMTP connections to Message Connector are either allowed or denied. By default, no filter is defined and connections are allowed from all IP addresses.

Each line in the **Source IP filter** field defines a filter and starts with an Allow or Deny keyword, followed by the CIDR (Classless Inter-Domain Routing) notation of an IP range. These filters are compared with the source IP address of a request. If a source IP address falls in a category of a filter starting with Allow, the SMTP connection for that IP address is accepted.

For example, Allow 10.20.30.0/24 allows request from IP addresses from 10.20.30.0 to 10.20.30.255.

The first matching filter defines whether the request should be allowed or denied. If filters are defined, but no filter matches the incoming source IP address request, the request is denied.

Access other user's mailbox

You can access other mailboxes using the following options.

Access using Exchange Impersonation

Using Exchange Impersonation, a single user can access multiple users' mailboxes. This option is available only for EWS import source. The user must have permission to access the mailboxes.

Access a shared mailbox

Multiple users can access a common shared mailbox. The Administrator can create a shared mailbox and give access to multiple users for this shared mailbox. These users will have access to this shared mailbox along with their own mailboxes.

The following table lists the differences between Exchange Impersonation and shared mailbox.

	Exchange Impersonation	Shared mailbox
Administered by	Administrator	Administrator
Used by	Exchange Web Services	Any mailbox client
Configuration	Per impersonator	Per user who need to be given access to the shared mailbox
Rights	Broad	Granular

Permissions for OAuth

Assign the following permissions for using OAuth authentication.

Protocol	Grant type	Minimum set of Microsoft Entra ID API permissions required
MS Graph	Resource Owner Password Credentials	User.Read (delegated) Mail.ReadWrite (delegated) Mail.ReadWrite.Shared (delegated)
	Authorization Code	User.Read (delegated) Mail.ReadWrite (delegated) Mail.ReadWrite.Shared (delegated)
	Client Credentials	Mail.ReadWrite (application)
IMAP	Resource Owner Password Credentials	Not applicable
	Authorization Code	User.Read (delegated) Mail.ReadWrite (delegated) Mail.ReadWrite.Shared (delegated) IMAP.AccessAsUser.All (delegated)
	Client Credentials	Not supported by Microsoft Entra ID.

Protocol	Grant type	Minimum set of Microsoft Entra ID API permissions required
POP3	Resource Owner Password Credentials	Not applicable
	Authorization Code	User.Read (delegated) Mail.ReadWrite (delegated) Mail.ReadWrite.Shared (delegated) POP.AccessAsUser.All (delegated)
	Client Credentials	Not supported by Microsoft Entra ID.



In case of Authorization code grant for MS Graph, IMAP, and POP3:

- The scope **offline_access** must be passed inside the scopes parameter while requesting for the authorization code.
- Passing the scopes **openid** and **profile** inside the scopes parameter while requesting for the authorization code is optional.

For MS Graph with Resource Owner Password Credentials, do the following to configure Default client type in Microsoft Entra ID:



If **Default client type** is set to **YES**, then do not specify the Client secret. Otherwise, specify the Client secret.

1. Log in to <https://portal.azure.com/>.



Ensure that the you have necessary permissions to change the application settings.

2. Click the **View** button for **Manage Microsoft Entra ID**.
3. From the **Manage** menu, click **App registrations**.
4. In the right pane, select the application you have created in Microsoft Entra ID.
5. From the **Manage** menu, click **Authentication**.
6. Under **Advanced settings** in the right pane, set the value of **Default client type** to **Yes**.
7. Click **Save**.
8. Restart the Kofax Message Connector Service.

Registry settings to enable TLS v1.1 and TLS v1.2 support for EWS

For EWS to send TLS v1.1 and TLS v1.2 confirming requests and messages to Microsoft Exchange Server, modify or add specific registry keys for both client (Message Connector) and Exchange Server.

Prerequisites:

- Install the required .NET Framework updates to enable TLS v1.1 and TLS v1.2.

- For both client and server, upgrade .NET Framework for the applicable Operating System in use.

i If a specific .NET Framework update is already installed or if an update is not required (in case a higher version of .NET Framework which supports TLS v1.1 and TLS v1.2 is already installed), the following error is displayed: The update is not applicable to your computer.

Enable TLS v1.1 and TLS v1.2 for Message Connector

To enable TLS v1.1 on a computer where Message Connector is installed, add or modify the following registry sub keys.

Operating System Type	Registry Path	Sub key	Type	Description
64-bit	HKEY_LOCAL_MACHINE\SOFTWARE\Microsoft\.NETFramework\v2.0.50727	SystemDefaultTlsVersions	dword	Set this sub key value to 1
64-bit	HKEY_LOCAL_MACHINE\SOFTWARE\Wow6432Node\Microsoft\.NETFramework\v2.0.50727	SystemDefaultTlsVersions	dword	Set this sub key value to 1
32-bit	HKEY_LOCAL_MACHINE\SOFTWARE\Microsoft\.NETFramework\v2.0.50727	SystemDefaultTlsVersions	dword	Set this sub key value to 1
32-bit/64-bit	HKEY_LOCAL_MACHINE\SYSTEM\CurrentControlSet\Control\SecurityProviders\Schannel\Protocols\TLS 1.1\Client	DisabledByDefault	dword	Set this sub key value to 0.
32-bit/64-bit	HKEY_LOCAL_MACHINE\SYSTEM\CurrentControlSet\Control\SecurityProviders\Schannel\Protocols\TLS 1.1\Client	Enabled	dword	Set this sub key value to 1.

To enable TLS v1.2 on a computer where Message Connector is installed, add or modify the following registry sub keys.

Operating System Type	Registry Path	Sub key	Type	Description
64-bit	HKEY_LOCAL_MACHINE\SOFTWARE\Microsoft\.NETFramework\v2.0.50727	SystemDefaultTlsVersions	dword	Set this sub key value to 1
64-bit	HKEY_LOCAL_MACHINE\SOFTWARE\Wow6432Node\Microsoft\.NETFramework\v2.0.50727	SystemDefaultTlsVersions	dword	Set this sub key value to 1
32-bit	HKEY_LOCAL_MACHINE\SOFTWARE\Microsoft\.NETFramework\v2.0.50727	SystemDefaultTlsVersions	dword	Set this sub key value to 1
32-bit/64-bit	HKEY_LOCAL_MACHINE\SYSTEM\CurrentControlSet\Control\SecurityProviders\Schannel\Protocols\TLS 1.2\Client	DisabledByDefault	dword	Set this sub key value to 0.

Operating System Type	Registry Path	Sub key	Type	Description
32-bit/64-bit	HKEY_LOCAL_MACHINE\SYSTEM\CurrentControlSet\Control\SecurityProviders\Schannel\Protocols\TLS 1.2\Client	Enabled	dword	Set this sub key value to 1.

Enable TLS v1.1 and TLS v1.2 for Exchange Server

To enable TLS v1.1 on a computer where Microsoft Exchange Server is running, add or modify the following registry sub keys.

Operating System Type	Registry Path	Sub key	Type	Description
32-bit/64-bit	HKEY_LOCAL_MACHINE\SYSTEM\CurrentControlSet\Control\SecurityProviders\Schannel\Protocols\TLS 1.1\Client	DisabledByDefault	dword	Set this sub key value to 0.
32-bit/64-bit	HKEY_LOCAL_MACHINE\SYSTEM\CurrentControlSet\Control\SecurityProviders\Schannel\Protocols\TLS 1.1\Client	Enabled	dword	Set this sub key value to 1.
32-bit/64-bit	HKEY_LOCAL_MACHINE\SYSTEM\CurrentControlSet\Control\SecurityProviders\Schannel\Protocols\TLS 1.1\Server	DisabledByDefault	dword	Set this sub key value to 0.
32-bit/64-bit	HKEY_LOCAL_MACHINE\SYSTEM\CurrentControlSet\Control\SecurityProviders\Schannel\Protocols\TLS 1.1\Server	Enabled	dword	Set this sub key value to 1.

To enable TLS v1.2 on a computer where Microsoft Exchange Server is running, add or modify the following registry sub keys.

Operating System Type	Registry Path	Sub key	Type	Description
32-bit/64-bit	HKEY_LOCAL_MACHINE\SYSTEM\CurrentControlSet\Control\SecurityProviders\Schannel\Protocols\TLS 1.2\Client	DisabledByDefault	dword	Set this sub key value to 0.
32-bit/64-bit	HKEY_LOCAL_MACHINE\SYSTEM\CurrentControlSet\Control\SecurityProviders\Schannel\Protocols\TLS 1.2\Client	Enabled	dword	Set this sub key value to 1.
32-bit/64-bit	HKEY_LOCAL_MACHINE\SYSTEM\CurrentControlSet\Control\SecurityProviders\Schannel\Protocols\TLS 1.2\Server	DisabledByDefault	dword	Set this sub key value to 0.
32-bit/64-bit	HKEY_LOCAL_MACHINE\SYSTEM\CurrentControlSet\Control\SecurityProviders\Schannel\Protocols\TLS 1.2\Server	Enabled	dword	Set this sub key value to 1.



- Enable both server and client (Message Connector) sub keys for the Exchange Server and then restart the computer.
- To support this feature on Exchange Server 2013, install the latest updates available for Exchange Server 2013. Additionally, install the [CU16](#) update. We recommend to install latest updates for all Exchange Servers in use.

Windows Failover Clustering

Message Connector can run in a Windows failover cluster. This ensures that if one computer in a cluster fails, another continues automatically without any manual steps or prolonged service interruption.

There are two possible installation options:

- Entire Message Connector installed on the shared disk (recommended).
- Only Message Connector storage installed on the shared disk.

Make sure the following prerequisites are met:

- Windows Server failover cluster is installed and configured.
A shared disk with 1 GB or more explicitly owned by Message Connector; it should not be available for other applications.
- Third-party applications needed for document conversion, such as Microsoft Office, OpenOffice.org, LibreOffice or TotalHtml installed on all cluster nodes.



Install these applications to the same local path.

TotalAgility can also run in a failover cluster.

For an active/active Windows cluster configuration, multiple instances of Message Connector on one computer are required. For installing multiple Message Connectors on one computer, refer to the *Kofax TotalAgility Installation Guide*.

Install Message Connector on a cluster (shared application)

1. Stop all cluster nodes except one.
2. Log on to the cluster node and install Message Connector on the shared disk.
If this is the first node:
 - a. Start the Message Connector Configuration.
 - b. In the **Storage file** field (**General** tab), type the path and name of the storage file on the shared disk.
 - c. It is recommended to change the **Trace location** (**Trace settings** tab) to the shared disk as well.
 - d. Save the configuration.

3. Stop the Message Connector service.
4. Change the Windows user under which Message Connector is running. The user must be a domain user with local administrator rights (same user for all cluster nodes).
5. Stop the cluster node.
6. Repeat steps 1, 2, 4, and 5 for all other nodes.
7. Continue with [Configure clustered service and IP address](#).

Message Connector configuration behaves differently when running in a clustered environment:

- When Message Connector is installed in shared application mode, the shortcuts to "Message Connector Configuration" and "Message Connector Monitor" in the Start menu may only be run on the cluster node that is the current owner of the clustered Message Connector service. The shared disk with the Message Connector working folder is only available to this one cluster node. Do not start the configuration shortcut on other than the active node!
To prevent erroneous situations, it is recommended to use a remote desktop connection to the cluster and start the configuration tool there. For the remote connection, use the IP address described in [Configure clustered service and IP address](#).
- When the Message Connector runs as a clustered service, the Message Connector Configuration application cannot restart the service, because the service is under control of the cluster. Simply save configuration changes, then take the service offline via Failover Cluster Management, and bring it online again.

Install Message Connector on a cluster (shared storage)

1. Log on to the cluster node and install Message Connector locally.
2. Start the Message Connector Configuration. In the **Storage file** field (**General** tab), type the path and name of the storage file on the shared disk. It is recommended to change the **Trace location** (**Trace settings** tab) to the shared disk as well.
3. Change the Windows user under which Message Connector is running. The user must be a domain user with local administrator rights (same user for all cluster nodes).
4. Repeat steps 1 and 3 for all nodes.
5. Continue with [Configure clustered service and IP address](#).

Message Connector configuration behaves differently when running in a clustered environment:

- When Message Connector is installed in shared storage mode, changes in Message Connector configuration must be performed on all nodes.
- When the Message Connector runs as a clustered service, the Message Connector Configuration application cannot restart the service, because the service is under control of the cluster. Simply save configuration changes, then take the service offline via Failover Cluster Management, and bring it online again.
- If you configure the storage file to a non-default location, this file will not be removed when uninstalling the product.

Configure clustered service and IP address

1. On the active cluster node, start **Failover Cluster Manager** from the **Administrative Tools**.
2. Open the cluster node in the tree view and right-click **Services and Applications**. Select **Configure a Service or Application** from the context menu. The High Availability Wizard starts.

3. When prompted to select a service or application from the list, choose **Generic Service**.
4. In the next screen, select the Message Connector or TotalAgility service, as appropriate.
5. In the next screen, assign a name and an IP address to the clustered service.
6. The clustered service will be available via this name and IP address later on.

 If you are using SSL, use the name of the clustered service when requesting a certificate.

7. When prompted to select the storage volume, select the shared disk.
8. Configure TotalAgility, Message Connector, and all other applications (such as SMTP email clients) to access using the IP address assigned to the clustered service.

Availability of Clustered Service

Failover behavior is configurable via the Failover Cluster Management application. If the service stops, the cluster either restarts the service or moves the ownership to another cluster node (that is, starts the service on the other node). By default, the service can be restarted twice within six hours before failover occurs.

For Message Connector, the failover takes about 2 - 3 minutes. During failover, no HTTP or SMTP connections are accepted. After a failover, clients can again access the Message Connector, using the same name and IP address. Configuration and stored messages are available as before. The list of all mailboxes must be explicitly reloaded (this is done by TotalAgility).

Uninstall Message Connector on a Failover Cluster

1. Using Failover Cluster Administration, take the clustered service offline and delete it.
2. Uninstall Message Connector from every node.
3. If you were using the shared storage mode, manually delete the storage file from the shared disk.

Network Load Balancing

The SMTP of Message Connector can run as a part of a Windows Network Load Balancing (NLB).

A Message Connector NLB cluster can be used to add scalability, load balancing, and high availability to the SMTP in scenarios, where the sender SMTP can only be configured to send to a particular server machine defined by a single IP address.

The Windows NLB concept by itself provides failover only for the case when an NLB node in the cluster is completely shut down: NLB directs all TCP-based traffic automatically only to the working NLB nodes.

However, NLB does not provide a failover solution for the case when a node is running but the TCP-based services on the node (in our case SMTP listeners) have problems, or if the service is stopped.

Therefore, Message Connector includes a feature called NLB Port Control that monitors the health of its processes. In case of problems, the port control makes the node unavailable.

Simple variant

In this variant, either Windows NLB or a hardware NLB is used to distribute the load to two or more computers. All computers run in parallel. You can continue to add computers as needed.

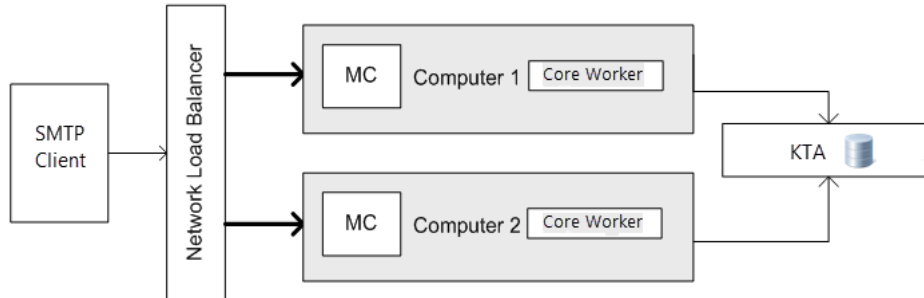

Active/active Windows cluster

In the active/active Windows cluster, two independent instances of Message Connector run on a single computer. This variant combines network load balancing with failover.

During normal operation one of these Message Connectors is active on each computer so that the system load is distributed across both computers.

If one machine fails, the passive instance on the second computer is activated and continues to process documents.

The active/active cluster configuration can be used with any input service. However, if you want to use SMTP input with a single IP address, an external load balancer is required.

You could also run TotalAgility as a clustered service, but this does not support the active/active scenario, because only one instance of TotalAgility is supported on a computer.

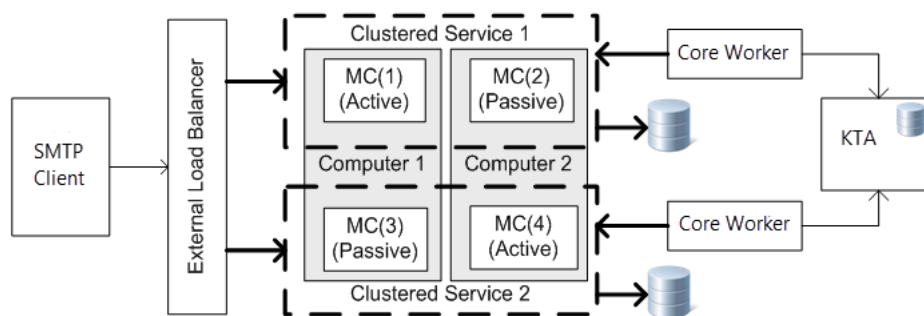

Restrictions

The NLB port control still leaves a short unavailability time window (usually 1 to 8 seconds) when the failover is not provided and an SMTP connection to the common NLB IP address fails. This always occurs in the following situations:

- **Unavailability time window when Message Connector node stops abruptly:** In this case it is the NLB (and not the port control) that handles this situation. NLB requires ~5 seconds to detect a failed node. NLB requires 2 to 3 seconds to remove the failed node and redistribute its load to the live nodes.

- **Unavailability time window when a node starts:** Some seconds elapse between when the NLB service starts (with enabled ports - depends on the cluster host configuration) and when the Message Connector with port control starts. You can eliminate most of this delay by changing the **Default state** to **Suspended** and selecting **Retain suspended state after computer restarts** when creating a new cluster. See [Install Windows NLB](#).
- **Unavailability time window at Message Connector process crash:** Some (1...3) seconds elapse until the Message Connector port control detects the crash and the disables the ports for NLB.

Nevertheless, if the SMTP client supports retries, the second attempt will presumably be outside of this time window and the connection request will be directed to a working node.

Install Windows NLB

1. Install Windows NLB on each Message Connector node.
On Windows Server, NLB must be installed as an additional feature of the operating system.
 - a. Start Server Manager.
 - b. Select **Features**.
 - c. Click **Add Features**.
 - d. Select **Network Load Balancing**.
 - e. Click **Next**, then click **Install**.
2. Configure a fixed IP address on each node.
3. The recommended method to create an NLB cluster is using the Windows Network Load Balancing Manager. Run "nlbmgr".
4. Create a new cluster:
 - a. Right-click **Network Load Balancing Cluster** and select **New Cluster**.
 - b. Specify an IP address of one of the cluster hosts and click **Connect**. Select an interface and click **Next**.
 - c. It is recommended to change the **Default state** to **Suspended** and to select **Retain suspended state after computer restarts**. Message Connector updates the state after startup. Click **Next**.
 - d. Click **Add** and specify the cluster IP address. Click **OK**, then click **Next**.
 - e. In the **Full Internet name** field, enter the name of the cluster computer.
 - f. Select **Multicast** (unless you have at least 2 network adapters on each node). Click **Next**.
 - g. Click **Add** to add port rules for SMTP (default 25). Select **Multiple host** as a **Filtering mode** and set **Affinity** to **None**.
 - h. Click **Finish**.
5. Add additional cluster nodes:
 - a. Right-click the cluster and select **Add Host**.
 - b. Specify an IP address of the node and click **Connect**. Select an interface and click **Next**.
 - c. Click **Next**, then **Finish**.

Operation and maintenance

Message Connector provides log files that can help for troubleshooting. Log files are stored in the application / program data folder for all users. The default path:

```
C:\ProgramData\Kofax\KIC-ED
```

Manage logs in Message Connector

To manage logs in Message Connector:

1. Start the Message Connector Configuration from the Kofax group in the Windows Start menu.
2. Click **Advanced** to display additional configuration options.
3. Edit the settings on the **Advanced** tab.
 - The default values (TraceLevel 10 and MessageTraceSize 1) provide basic trace information (usually sufficient) without negatively impacting the performance.
 - Troubleshooting values (TraceLevel 40 and MessageTraceSize 100000) provide lot of information; these are more suitable when duplicating error situations in controlled environment.

Refer to Message Connector Help for more information about the parameters.

4. Find log files in <path>\MC\log.
5. Click **Save** and then click **Exit and restart service**.

Manage logs in KFXConverter

The default name of the log file is KFXConverter.log. The default location is C:\ProgramData\Kofax\KFXConverter. The maximum log file size is 5 MB. The file is overwritten when the maximum size is reached. You can specify another log file using the command line option `-logFile <path>\<filename>`.

For example: `-logFile C:\temp\mylog.log`

In Message Connector, for PDF/A normalization using **Standard (Recommended)** option in **PDF to PDF/A conversion engine**, conversion results are logged in StandardPDFEngine.log.

For logging additional trace statements in case of errors or exceptions, set the `DebugLog` parameter in KFXConverter.ini file to true. See [Configure Kofax Converter](#).

Message Connector status monitor

Message Connector provides a monitoring interface with the following main functions:

- Sending test messages
- Viewing documents in storage
- Managing failed documents
- Monitoring Message Connector status

Send test messages

Use this section to verify the functionality of the Message Connector by sending a test fax or an email. To verify both tests, send a message in a loop (Message Connector --> Message Connector). Core Worker service will then import the message to Kofax TotalAgility.

Send a test fax

1. On the Windows Start menu, click **Kofax > Message Connector Monitor**.
2. On the **Menu**, click **Test Fax**.
3. In the **Number to Dial** box, enter a number.
4. Click **Send Fax**.
The "Server returned ok!" message appears.
5. On the **Menu**, under **Outbound Status**, click **Processed** to find the sent fax.
6. Optionally, click **Inbound Status > Active** and view the message, if the Kofax TotalAgility service is not running.

Send a test mail

1. On the Windows Start menu, click **Kofax > Message Connector Monitor**.
2. On the **Menu**, click **Test Email**.
3. In the **To** box, enter an email address.
4. Click **Send Email**.
The "Server returned ok!" message appears.

Message Connector storage

Message Connector stores all messages and files received from various sources to its internal storage before they are imported to Kofax TotalAgility.

The storage is managed automatically. Files and messages that are correctly imported to Kofax TotalAgility are marked for deletion and they are removed when the storage is full. Files and messages that are not correctly imported to Kofax TotalAgility may fill the storage. See [Manage failed messages manually](#).

The storage includes multiple folders.

- Under **Inbound Status**, click **Active** to list documents that are active and have been received by Message Connector but not yet delivered to Kofax TotalAgility. When the "archive to folder" function is activated, documents remain in this folder until the archiving has been concluded.
- Under **Inbound Status**, click **Active > Failures** to list documents that have been received by Message Connector but are not delivered to Kofax TotalAgility. Documents appear in this folder only if the **Keep failed** setting is selected in configuration. When the archive to folder function is activated, documents remain in this folder until the archiving has been concluded.

 Documents remain in this folder until they are handled manually by an operator (reactivated or deleted). If not monitored, this can cause full storage and stop processing of documents.

- Under **Inbound Status**, click **Processed** to list documents delivered to Kofax TotalAgility. If Keep Failed is cleared, this folder also contains documents that permanently failed to import to Kofax TotalAgility. Processed documents are deleted automatically from the storage when space for active messages is needed.
- Under **Inbound Status**, click **Processed** > **Failed** to list documents that permanently failed to import to Kofax TotalAgility (ensure that the Keep Failed setting is clear). These documents are deleted automatically from the storage when space for active documents is needed.
- Under **Outbound Status**, click **Active** to list test fax messages which are queued for sending or are currently being sent.
- Under **Outbound Status**, click **Processed** to list test fax messages which are queued for sending or are currently being sent.
- Under **Outbound Status**, click **Processed** > **Failed** to list test fax messages that could not be sent.

View messages in the storage

1. On the Windows Start menu, click **Kofax** > **Message Connector Monitor**.
2. On the **Menu**, go to **Inbound Status** or **Outbound Status** for any storage folder..
3. Select the message and click the **View/Save** message.
 - Email messages are available as EML files. You can view these files in Outlook Express or Windows Live Mail or any other mail client that supports EML.
You can also view EML files in Microsoft Outlook. To view an EML file in Outlook 2007, follow the instructions from Microsoft documentation available at the Microsoft website. Outlook 2010 can directly open these files.
 - Fax messages are available in multipage TIFF format. You may need a special viewer to view this format properly.

Manage failed messages manually

Use this section, to manually manage messages that could not be delivered to Kofax TotalAgility. Depending on the Keep Failed configuration in the Message Connector Configuration User Interface, problematic messages can be found in either storage folder:

- Inbound > Active > Failures
- Inbound > Processed > Failures

Reactivate messages

It is important to monitor the Inbound > Active > Failures folder, as messages in this folder can potentially fill the entire storage space. These messages can be reactivated and Kofax Message Connector will retry to import them to Kofax TotalAgility.

1. On the Windows **Start** menu, click **Kofax** > **Message Connector Monitor**.
2. On the **Menu**, under **Inbound Status**, click **Active** > **Failures**.
You can view the contents of a message to investigate the problem.
3. Click **View** / **Save**.
4. You can either reactivate the message or delete it.

A reactivated message is moved back to the "Inbound Status > Active" folder. A deleted message is moved to the "Inbound Status > Processed > Failures" folder.

Rerun messages

The "Inbound Status > Processed > Failures" folder contains messages that are already marked for deletion. When the storage gets full, these messages are lost. However, as long as they are available, you can rerun them and create a copy of any message-as if it had just arrived-in the "Inbound Status > Active" folder.

1. On the Windows **Start** menu, click **Kofax > Message Connector Monitor**.
2. On the **Menu**, under **Inbound Status**, click **Processed > Failures**.
3. Click **View / Save** to view the contents of a message.

You cannot delete these messages; they are already deleted. However, you can try to rerun any message. A copy of this message is created in the "Inbound Status > Active" folder.

Chapter 6

Kofax Document Converter

Normally, the document conversion takes the default document conversion settings in TotalAgility. However, if the Kofax Document Converter is not an acceptable alternative to MS Office for converting MS Office documents, you may need to modify these settings.

The Kofax Document Converter utility (KFXConverter) provides an interface to modify the default configuration settings for document conversion. See *Kofax TotalAgility Document Converter Help*.

This utility is installed when you install Transformation Server. Make sure that you configure these settings on each Transformation Server instance separately.



- You cannot modify the default parameters in the Document Converter utility in an Azure environment. You can only use KFXConverter for document conversion.
- The document conversion advanced configuration using the Document Converter utility has to be performed on each Transformation Server separately.
- You cannot modify the default parameters in the Document Converter utility, as the utility is not accessible in a Docker environment.

Make sure that you provide appropriate licenses for the following third-party applications that may be required for the Document Converter:

- Adobe Experience Manager Server
- Total HTML ConverterX
- OpenOffice.org
- Microsoft Office

Advanced configuration for document preparation

Document Converter can normalize text, HTML, OpenOffice.org, and Microsoft Office documents to PDF. The images are not normalized to PDF, but they are always imported in their original format.

When you select to normalize your message content to PDF, Kofax Document Converter actually normalizes all non-PDF parts of the message to an ISO-standardized version of PDF, the PDF/A. However, the Document Converter can also normalize PDF parts to PDF/A.



- If "Microsoft Office" is selected as the normalization tool in "MS Office and selected Open Office documents", normalization of Excel documents results in PDF documents rather than PDF/A documents.
- Do not open MS Office applications or process MS Office documents on a computer where the document conversion with MS Office is running.

1. To run the utility, on the Windows Start menu, click **Kofax > Document Converter Configuration**.
2. Expand the **Document conversion** tab.
3. Select the tool for converting Microsoft Office documents.
 - If using OpenOffice.org, make sure that you have installed the necessary extension. See [Third-Party software](#).
 - If using Microsoft Office, and if the operating system is Windows Server 2008 R2, Windows Vista, or later, select the Windows user account to use for Microsoft Office DCOM automation. For initial tests and troubleshooting, use the interactive user. For production use, specify an administrator user.



When you use MS Office as a conversion tool, you can only convert one document on one computer at a time. This may prevent the Transformation Servers from utilizing the full potential of the computers on which they are run. Therefore, we recommend that you create separate Transformation Server Pools for document conversion using MS Office. All other conversion activities can be processed on different Transformation Servers. For more information, see [Transformation Server Pools](#).

4. Select the tool for converting HTML documents.
5. Click **Save** and **Exit configuration**.

Configure PDF variant

You can select one of several supported PDF variants by editing a batch file.

1. Open the following folder (assuming the default installation path on a 64-bit operating system):
`C:\Program Files (x86)\Kofax\Document Converter\Scripts`
2. Edit the file `KFXConverter.bat` in a text editor.
3. Configure the type of PDF produced when converting non-PDF documents to PDF.

If you are using Kofax Converter for normalization, perform the following substeps. For any other converter, such as Microsoft Office, this setting does not modify the converted PDF type.

- a. Find the string `IF %ConvertToType%== "PDF/A" (.`
- b. Edit the line immediately below `set ConvertToType="PDF/A1B"`. The following values are supported:
 - PDF
 - PDF/A1A
 - PDF/A1B (default)

- PDFA2B
4. Configure the type of PDF produced when normalizing existing PDF documents.
 - a. Find the string `IF %ConvertToType%== "PDFAn" (.`
 - b. Edit the line immediately below `set ConvertToType="PDFA1BN"`. The following values are supported:
 - PDF (disables PDF normalization)
 - PDFA1AN
 - PDFA1BN (default)
 - PDFA2BN
 5. Save and close the file.

Configure Microsoft Office

To use Microsoft Office for document normalization, verify the following:

- Install a supported version of Microsoft Office on the same computer as Document Converter.
- Install at least one printer (required for Microsoft Excel document conversion).
- Start all applications (Word, Excel, and PowerPoint) at least once and respond to the initial prompts.
- If using a 64-bit version of Microsoft Office, create the following folder:

```
C:\Windows\System32\config\systemprofile\Desktop
```

Configure OpenOffice.org extension

Kofax Document Converter supports the normalization of Microsoft Office documents using Microsoft Office or OpenOffice.org.

If using OpenOffice.org, you must install the OpenOffice.org extension on the same computer as the Document Converter.

To install this extension, do the following:

1. Install a supported version of OpenOffice.org. See [Third-Party software](#) for supported versions.
2. Shut down all OpenOffice.org processes (including Quickstarter).
3. From the installation media, browse to `TotalAgility\KIC\Export\MC\OpenOfficeExtension` and run `setup.exe`.
4. Click **Browse**. Windows File Explorer displays the content of the installation folder.
5. Go to `MC\OpenOfficeExtension` and run `Install.bat`.
6. Wait until the extension is installed.

You can manage installed OpenOffice.org extensions by selecting **Tools>Extension Manager from any OpenOffice.org application menu**. The extension list should include "Kofax Conversion for OpenOffice 1.0.". An installed extension displays the icon  indicating that this extension is installed for all users.

Configure Total HTML ConverterX

You can use Total HTML ConverterX for converting HTML documents, such as email messages in HTML format.

Install Total HTML ConverterX on the same computer as Document Converter. Use the default installation path.

 For initial testing, you can use the trial version of Total HTML ConverterX.

Configure Kofax Converter

By default, each document conversion profile uses the default KFXConverter settings for document conversion. You can modify the Kofax Converter settings for each document conversion profile in the TotalAgility Designer.

For detailed description of KFXConverter settings, refer to the "Document conversion profiles" topic in the *Kofax TotalAgility Help*.

For input and output formats supported by document converter, see **Appendix H: Supported input and output formats**.

Flatten XFA files

You can import and flatten the PDF documents with Adobe XML Forms Architecture (XFA forms) using the Document Converter. To achieve this, you must install Adobe Experience Manager Server and make it accessible to TotalAgility.

 If support for Adobe LiveCycle is available, you can also use Adobe LiveCycle for conversion of XFA Forms.

Prerequisites for using the Adobe Experience Manager Server:

- Install the Adobe Experience Manager software on a different computer than TotalAgility. However, to decrease the probability of timeouts and retries, we recommend that you install the software in the same network LAN segment.
- Ensure that the Output service is running, and its web service is enabled and working.
- The minimum supported version of Adobe Experience Manager Server is ES3.



- Any limitations imposed by Adobe are applicable. For example, only XFA PDFs with no rights, signature, or certification can be converted to PDF or PDF/A. See Adobe Experience Manager documentation for more information.
- When an exception occurs while using Adobe Experience Manager, TotalAgility reports the exception in its log file, and the error is treated as a standard document conversion error.

To configure the Adobe Experience Manager Server, do the following:

- In Document Converter, specify the information for connecting to Adobe Experience Manager Server on the **Adobe Experience Manager** tab.
- In the Capture module of TotalAgility Designer, enable the **Flatten XFA forms to PDF documents using Adobe Experience Manager** setting when configuring the document conversion profiles.



- Enabling this setting may have impact on the performance as each PDF document is sent to the Document Converter to determine whether it is an XFA form or standard PDF.
- For more information on the document conversion profiles, see the *Kofax TotalAgility Help*.

Image normalization rules

During the image normalization process, the following rules are applied to manage the image height, width, and resolution.. The first matching rule governs the conversion.

1. If the resolution of an incoming image matches the requested resolution, the image is not changed.
2. If the `MaxPrintSize` parameter is set to a certain value and if the print size of an image exceeds this value, then the image is changed without retaining the original print size. This is done by changing the resolution without resampling the image. The default location of the file is:
`C:\Program Files (x86)\Kofax\KIC-ED\MC\Scripts`. By default, `MaxPrintSize` is set to 60.
3. If the x and y resolutions are different, the image is re-sampled to the requested resolution (non-quadratic pixel case).
4. If the resolution value is wrong, it is set to a requested value without re-sampling the image. This changes the printing size of the image. To avoid quality loss, such images are not re-sampled. A resolution is wrong if one of the following conditions is true:
 - The resolution is below the `MindxResolution` value which is set to 96 dpi. If the `MindxResolution` is not set, ImageMagick returns 72 dpi.
 - The resolution exceeds 200 dpi and the width is less than 1500 pixels (19.5cm@200dpi).
 - The resolution exceeds 200 dpi and the height is less than 2000 pixels (25.4cm@200dpi).

5. If the resolution is higher than the requested resolution, the image is down-sampled to the requested resolution.
6. If none of the above listed rules applies, the image conversion depends on the configuration in the script file `image2tif.bat`. Open the file with a text editor and change the value in the line `Set ResetResolution=0`. The following values are available:
 - 0: Resample image and change resolution. This is the default option. Image file size is increased without improving the image quality. Re-sampling is a time-consuming operation that results in lower performance.
 - 1: Change the resolution without re-sampling. This reduces the print size of the image.
 - 2: Image is not changed. Set this value for best performance.

Manage conversion time for large files

To process some large size files, the default configured time may need to be adjusted. In such scenarios, to avoid timeouts, you can increase the default conversion time.

To increase the timeout value, do the following:

1. Open the `Create_Config.xslt` file from `C:\Program Files (x86)\Kofax\Document Converter\xcd` (default installation path).
2. Increase the value of the `<MaxTimeout>` parameter under `<ConversionOptions>`. Default value of `<MaxTimeout>` is `900000ms`.
3. If the `<MaxTimeout>` or `<ConversionOptions>` parameters are not available, add these parameters under `<TncDocConv>` as shown in the following example.

```
<TncDocConv>
    ...
    <ConversionOptions>
        <MaxTimeout>1200000</MaxTimeout>
    </ConversionOptions>
    ...
</TncDocConv>
```

4. Save and close `Create_Config.xslt`.
5. Run `configure.bat`.

Chapter 7

Assign TotalAgility access permissions

The following table lists the default full control access permissions for different areas of TotalAgility.

TotalAgility function/component	Full-control access permissions
Process	Designers
Business Rule	Designers
Resource	Designers
Settings	Administrators
Work Type	Designers
Lock Status Search	Designers
Job Clear Down	Administrators
Capture	Designers
Persona	Designers
Designer	Designers
Devices	Device Users
Capture Design	Designers

Chapter 8

Log on to TotalAgility in recovery mode

You can log on to TotalAgility in recovery mode by using the recovery mode session ID. Use this ID when the administrator is unable to log into TotalAgility Designer using the standard Federated Security (FS) login. The recovery mode session ID is unique and a new ID is generated with each installation. You can get the session ID from the system settings in the TotalAgility Designer. However, you can regenerate the session ID as needed.

To log on to TotalAgility in recovery mode, you should have full control or read/write permissions.

To obtain or update the recovery mode session ID:

1. Navigate to **System > System settings > Logon and authentication > User sessions**.
The **User sessions** dialog box is displayed. By default, the key has a session ID that can be used to log on.
2. To generate a new session ID, click **Generate** next to the **Recovery mode session ID** field.
3. Open the browser window and enter the recovery mode URL.
See "Configure federated security" in the *Kofax TotalAgility Help* for more information.
4. Enter the **Recovery mode session ID** obtained from the system settings and click **Validate**.
The Recovery mode page appears.
5. Enter the **Username** and **Password**.
6. Click **Login**.
The TotalAgility Designer is launched in recovery mode.

Appendix A

Security and compliance

This appendix describes the security and compliance requirements for TotalAgility.

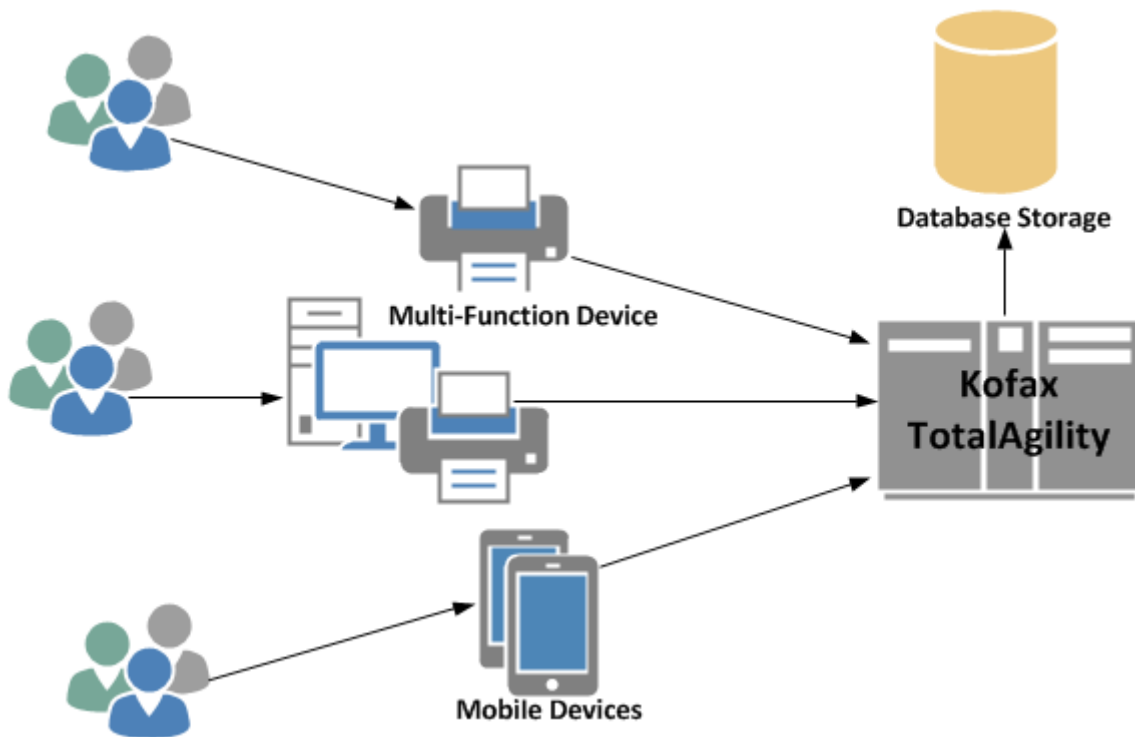

User login and authentication

Category	Authentication and Authorization
Description	User provides login credentials for Kofax TotalAgility application.

Security details	<p>Kofax TotalAgility supports synchronizing users/groups with Active Directory. This allows Kofax TotalAgility to take advantage of the corporate infrastructure for authentication and credential management via Windows Authentication.</p> <p>Kofax TotalAgility also has an application-specific authentication and authorization mechanism for convenience. This includes credential management and storage. Stored passwords are encrypted using Scrypt.</p> <p>Lastly, Kofax TotalAgility supports Federated Security to authenticate with identity providers that support the SAML 2.0 or Ws-Federation standards.</p>
------------------	---

Client transmits to Kofax TotalAgility server(s)

Category	Data in transit
Port	80 or 443
Protocol	HTTP or HTTPS
Description	Clients transmit to the Kofax TotalAgility servers.
Security details	All connectivity from Kofax TotalAgility clients (including Process/Form Designer, Forms Workspace, Transformation Designer, and MFPs) to the TotalAgility servers is via HTTP/HTTPS. HTTPS should be configured for maximum security.

Kofax TotalAgility server(s) transmits to another Kofax TotalAgility server(s)

Category	Data in transit
Port	Varies depending on protocol
Protocol	HTTP, HTTPS or WCF NET.TCP
Description	Kofax TotalAgility servers transmit to/from another Kofax TotalAgility server.
Security details	All Kofax TotalAgility components can be deployed on a single machine, in which case there is relatively low risk of a Third party intercepting transmission. You can alternately deploy Kofax TotalAgility components on multiple servers. In such a case, the servers should be co-located and/or physically protected, to mitigate the risk of interception. If further mitigation is desired, use IP sec or HTTPS to protect the connection between machines.

Kofax TotalAgility servers transmit to SQL server

Category	Data in transit
Port	Varies depending on protocol

Protocol	TCP/IP or Named Pipes
Description	Kofax TotalAgility servers transmit to/from database
Security details	The Kofax TotalAgility servers connect to the SQL database. Typically, the SQL Server system is co-located or otherwise physically protected such that transmission need not be otherwise encrypted. However, if such encryption is needed, you can encrypt the database connection via SSL.

Image and metadata storage

Category	Data at rest
Description	Image and metadata is stored.
Security details	Images and metadata are stored in the Kofax database, which is accessed through a configured system account. Database level encryption is also available using the encryption feature within the database itself. Whether or not file system and/or database encryption is enabled, passwords (for external systems or application-specific users), are further protected. Password credentials are stored using the AES GCM encryption algorithm and the Scrypt hashing algorithm (for end user passwords) approved by the Federal Information Processing Standard (FIPS) Publication 140-2 standard.

Appendix B

Active Directory synchronization

This appendix describes the Active Directory synchronization features supported by Kofax.

Active Directory domains

A domain is a group of computers that share a common directory database.

Child domain

Parent domains can be divided into sub-domains which are also called child domains. For example, the host name for a computer in the Irvine office could be abc.irvine.Kofax.com where abc is the computer name, Irvine is the child domain and Kofax.com is the parent domain. These domains in turn can have subdomains.

Additional domain (Cross domain)

Each Active Directory domain has a DNS domain name, such as Kofax.com. When one or more domains share the same directory data, they are referred to as a forest. In the DNS naming hierarchy, a domain name within a forest can be:

- Contiguous (child domain)
- Discontiguous: They form separate domain trees within the forest. In this example, the msnbc.com and microsoft.com domains form the roots of separate domain trees in the same forest.

Forests and trees

Windows .NET and 2000 domains can be grouped into trees and forests.

LDAP (Lightweight Directory Access Protocol)

LDAP, Lightweight Directory Access Protocol, is an Internet protocol. Kofax TotalAgility uses the LDAP protocol that represents the protocol for .NET/2000 domains.

The LDAP protocol lets you retrieve the information related to the objects contained in an Active Directory using a specific syntax. This syntax allows searching for directory objects and selecting them on the basis of their attributes.

LDAP query

Kofax TotalAgility uses an LDAP query to retrieve user, group and organizational unit details based on the following criteria:

- Search base (or base object): It's a start location. Kofax TotalAgility supports an Active Directory server name or a server name with the organization unit's path or group name.
- Scope: Specifies how deep the search should be performed. There are three kinds of scope:
 - Base: Restricts the search only to the base. For example, if the search base is a container object, its attributes are listed, but not the contents.
 - One level: Takes the search just beyond the base object, excluding the base object itself.
 - Subtree: Extends the search over the whole subdirectory (including the base object). A filter is used to single out the required elements in the specified subtree scope.
- Selection (or attribute description list): Determines which attributes of the selected objects are important.

Referral chasing

The referral chasing allows the parent directory server to retrieve information about users, groups or organizational units that are on other domain, such as a sub domain or an external forest.

Active Directory attributes

- ou (organizationalUnit)
- sAMAccountName
- cn
- dc (domainDNS)
- distinguishedName
- objectCategory
- objectClass
- objectGUID
- objectSid
- SID=S-1-5-21-3917318313-2927010959-1265295254-2115

Implement Active Directory synchronization

TotalAgility Active Directory synchronization is passive. It cannot add, update or delete anything in Active Directory. As an added security measure, it obfuscates the Object ID from Active Directory to store it as a Resource ID in TotalAgility (HEX conversion). It is not possible to locate the same resource in Active Directory even from the Resource ID from TotalAgility.

Synchronize active items

1. Create a List of OUs.

2. Create a List of Users in OU.
3. Create a List of Groups in OU.
4. Get changed Users and Groups in the system.
5. Set the value of the server variable, `sAD_CHASE_REFERRAL` to turn on or off the referral chasing.
 - True: To enumerate resources from parent and external domains/forest.
 - False: To enumerate resource from parent and child domains.
6. To enumerate child and additional domain resources, the "DC" string is modified based on the resource's path where the same server name is used for search.
7. To enumerate cross forest resources, account and domain information is retrieved from the SID, and the LDAP query is rebuilt to point to a new server.

Synchronize deleted items

TotalAgility supports delete synchronization for users, groups and categories.

To synchronize deleted items, set `isDeleted=TRUE`.

- Active Directory server should be configured to add deleted resources to the Delete container. Otherwise, this feature will not work.
- If a resource is deleted from Active Directory, it is deleted from TotalAgility during delete synchronization only if the resource is not in use.

Synchronize root level

- All the OUs and resources in Active Directory server will be imported to TotalAgility.
- The first synchronization takes time and thereafter, only newly added/deleted resources are synchronized..
- The resources from the User container will not be imported as they are not part of any OU. This is to restrict the import of unwanted resources, such as the computer, printer, domain controller and the rest.

Synchronize middle level

- Resources will be imported from the specified OU and its children OUs.
- If the target OU has a parent OU, specify the complete path for the target OU (Test OU). For example, `SERVER_NAME/OU=Test Parent, OU=Test OU`

 The resources from the Test parent will not be imported, as the target OU is the test OU.

- The resources from the User container will not be imported as they are not part of any OU; the only exception is when a group search is specified.

Perform group search

- Specified group and its members will be imported to TotalAgility.
- Option is available only for a group and not for user search.

- For root level synchronization, the group is searched in the complete Active Directory server.
- For mid-level synchronization, the group is searched in the specified OU and its children OUs.
- Only for Group search, resources from the User container will be imported to TotalAgility in the default category.

Synchronize cross domains

Group members residing in different domains or forests can also be imported to TotalAgility.

- Domain should be fully trusted or at least have trust to allow the LDAP search.
- Child Domain Sync: Regardless of Chase referral, flag resources will always be imported.
- Sub domain Sync: Chase referral should be true to import resources.
- External Forest Sync: Chase referral should be true to import resources.

Synchronize category within category

The OU structure in AD can be imported as is in TotalAgility.

- If the category name length is more than allowed in TotalAgility, or a category with the same name already exists in TotalAgility or any other database constraint, the category will not be imported and an error will be logged with the exact cause. Resources to invalid category will be added to the default category.
- For example, if synchronizing Group "G1" which is in OU1 and some members of G1 are in different OUs, and the OUs are not in current search path (that is, with mid-level synchronization).
 - All the parent OUs for OU1 will be imported. For example, OU1- > Parent of OU1-> Parent of (Parent of OU1).

 Only parent OUs will be synchronized, and not the resources inside those OUs.

- If members are imported, then their parent OUs up to the root level will be imported same as the first bullet point.

Synchronize groups within groups

The Group structure in Active Directory can be imported as is in TotalAgility.

- Circular group synchronization is supported even within external domains (such designs should be avoided).
- Groups within groups in a cross domain is supported; that is, parent group in one forest and members are in child domain, sub domain or forest.
- If group or user name length is more than allowed in TotalAgility or any other database constraint, the resource will not be imported and an error will be logged with the exact cause.
- The complete group structure from Active Directory is retrieved in multiple parses through recursive call to LDAP Query. Each call to LDAP query returns single level group information and if group has subgroups then new query is fired on subgroup to retrieve its children and does until it finds the leaf node or circular group.

Implement chase referral

- The referral chasing will be turned on or off based on the value of the server variable AD_CHASE_REFERRAL.
- If it is on, resources from the parent and external domains/forest will be enumerated; otherwise, resources from parent and child domains will be enumerated.
- To enumerate child and additional domain resources, the "DC" string will be modified based on the resource's path, whereas the same server name will be used for search.
- To enumerate cross forest resources, account and domain information will be retrieved from SID, and the LDAP query will be rebuilt to point to the new server.

Appendix C

Lock activity performance

If you decide to lock activities based on the job expected finish time, you can improve the performance of TotalAgility by creating a new index on the LIVE_ACTIVITY table.

To create this index, run `Create_Job_Expected_Finish_Time_Index.sql` available at:

```
$:\Program Files\Kofax\TotalAgility\DatabaseScripts\SQL Server
```

The index file is installed with other SQL scripts during TotalAgility installation, but it is not executed. You must run it manually if you want to apply the index.

You can lock activities based on the job expected finish time by changing the value of the appSetting "CoreWorkerActivityOrder" in the Core Worker service or Transformation Server config files.

The supported values for CoreWorkerActivityOrder are:

ActivityPriority = 0

ActivityDueDate = 1

ActivityPriorityDueDate = 2

ActivityDueDatePriority = 3

JobPriority = 4

JobDueDate = 5

JobPriorityDueDate = 6

JobDueDatePriority = 7

The new index improves performance if the value of CoreWorkerActivityOrder is 5 or 7.

Appendix D

CoreWorkerActivityOrder setting

By default, the CoreWorker service retrieves processed automatic activities in the order of activity due date and priority. However, you can change the order of the activities by running the Configuration Utility.

 The Configuration Utility is available on the installation media and must be manually copied to your Kofax TotalAgility server.

The possible values are as follows.

Value for Activity/Job	Description
0 (Activity Priority)	Process activities based on activity priority.
1 (ActivityDueDate)	Process activities based on activity due date.
2 (ActivityPriorityDueDate)	Process activities in the order of activity priority and activity due date.
3 (ActivityDueDatePriority)	Process activities in the order of activity due date and activity priority. (Default)
4 (JobPriority)	Process jobs based on job priority.
5 (JobDueDate)	Process jobs based on job due date.
6 (JobPriorityDueDate)	Process jobs in the order of job priority and job due date.
7 (JobDueDatePriority)	Process jobs in the order of job due date and job priority.

1. Run the Configuration Utility from your installed location.
2. On the **Core Worker** settings tab, change the value for `CoreWorkerActivityOrder` as required.
3. Click **Save**.

Lock activities

By default, the CoreWorker service locks activities for processing in the order of activity due date and priority. You can change the default order by updating the `CoreWorkerActivityOrder` app key in the CoreWorker configuration file.

If you select the job priority and expected finish time as the order, add the following index in the TotalAgility main database to improve performance.

```
CREATE NONCLUSTERED INDEX [IDX_JOB_PRIORITY] ON [DBO].[JOB]  
(
```

```
[PRIORITY] ASC,  
[EXPECTED_FINISH_TIME] ASC  
)  
INCLUDE ( [JOB_ID])
```

 The same configuration file settings also apply to the Transformation Server service.

Appendix E

Cross Origin Resource Sharing setting

Cross Origin Resource Sharing (CORS) in Kofax TotalAgility allows other domains to access the Kofax TotalAgility SDK APIs.

The `CorsAllowedOrigins` setting determines the origin or domains that can access the web server. You can enable CORS by running the Configuration Utility post installation.

 The Configuration Utility is available on the installation media and must be manually copied to your Kofax TotalAgility server.

1. Run the Configuration Utility from your installed location.
2. On the **Web** settings tab, enter the value for `CorsAllowedOrigins` as follows.
 - To access two different domains using CORS, such as `CompName1.domain1.com` and `CompName2.domain2`, configure the value as follows:

```
http://CompName2.domain2,http://CompName1.subdomain1.domain1.com
```

 Separate the two domains by a comma.

- To access all the origin or domains, use the following value: *
 - To disable CORS (default), do not enter any value.
3. **Save** the file.

Appendix F

Logging

Logging is used to record critical errors, such as database failures. All errors are written into the Windows Event log. This includes errors which occur in the services, and errors that occur when an SDK web service call is invoked.

TotalAgility uses the Unity logging framework which enables enhanced logging, through various configuration settings. The settings for logging are present but commented out in the configuration files. You can enable these settings to write logging to the configured files. The Unity logging framework allows configuration of logging output from a list of supported destinations.

You can enable Unity logging for the following server and services:

- Web Server
- Core Worker, Export Service, Streaming Service
- Transformation Server
- Reporting Server

You can configure logging to use different outputs, such as event log and log file. (Default: event log)

TotalAgility Web and Application Server

This section describes error logging configuration for the TotalAgility Application server.

Logging can be enabled in the following configuration files:

- Web.config
- Agility.Server.Core.WorkerService.exe.config
- Agility.Server.StreamingService.exe.config
- Agility.Server.Core.ExportService.exe.config

```
<loggingConfiguration name=""
tracingEnabled="true" defaultCategory="General">
<listeners>
<add name="Event Log Listener"
type="Microsoft.Practices.EnterpriseLibrary.Logging.TraceListeners.
FormattedEventLogTraceListener,
Microsoft.Practices.EnterpriseLibrary.Logging, Version=5.0.505.0, Culture=neutral,
PublicKeyToken=31bf3856ad364e35"
listenerDataType=
"Microsoft.Practices.EnterpriseLibrary.Logging.Configuration.
FormattedEventLogTraceListenerData,
Microsoft.Practices.EnterpriseLibrary.Logging,
Version=5.0.505.0, Culture=neutral,
```

```
PublicKeyToken=31bf3856ad364e35"
source="Total Agility" formatter="Text Formatter" log="" machineName="."
traceOutputOptions="None" />
</listeners>
<formatters>
<add
type="Microsoft.Practices.EnterpriseLibrary.Logging.Formatters.TextFormatter,
Microsoft.Practices.EnterpriseLibrary.Logging,
Version=5.0.505.0, Culture=neutral,
PublicKeyToken=31bf3856ad364e35" template="Timestamp:
{timestamp}{newline}&#xA;Message:
{message}{newline}&#xA;Category:
{category}{newline}&#xA;Priority:
{priority}{newline}&#xA;EventId:
{eventId}{newline}&#xA;Severity:
{severity}{newline}&#xA;Title:{title}{newline}&#xA;Machine:
{localMachine}{newline}&#xA;App Domain:
{localAppDomain}{newline}&#xA;ProcessId:
{localProcessId}{newline}&#xA;Process Name:
{localProcessName}{newline}&#xA;Thread Name:
{threadName}{newline}&#xA;Win32
ThreadId:{win32ThreadId}{newline}&#xA;Extended Properties:
{dictionary({key} - {value}{newline})}"
name="Text Formatter" />
</formatters>
<categorySources>
<add switchValue="All" name="General">
<listeners>
<add name="Event Log Listener" />
</listeners>
</add>
</categorySources>
<specialSources>
<allEvents switchValue="All" name="All Events" />
<notProcessed switchValue="All" name="Unprocessed Category" />
<errors switchValue="All" name="Logging Errors & Warnings">
<listeners>
<add name="Event Log Listener" />
</listeners>
</errors>
</specialSources>
</loggingConfiguration>
<exceptionHandling>
<exceptionPolicies>
<add name="Agility Exception Policy">
<exceptionTypes>
<add name="All Exceptions" type="System.Exception, mscorlib,
Version=4.0.0.0, Culture=neutral, PublicKeyToken=b77a5c561934e089"
postHandlingAction="NotifyRethrow">
<exceptionHandlers>
<add name="Logging Exception Handler"
type="Microsoft.Practices.EnterpriseLibrary.ExceptionHandling.
Logging.LoggingExceptionHandler,
Microsoft.Practices.EnterpriseLibrary.ExceptionHandling.Logging,
Version=5.0.505.0, Culture=neutral, PublicKeyToken=31bf3856ad364e35"
logCategory="General" eventId="100" severity="Error" title="Total Agility"
formatterType="Microsoft.Practices.EnterpriseLibrary.ExceptionHandling.
TextExceptionFormatter,
Microsoft.Practices.EnterpriseLibrary.ExceptionHandling,
Version=5.0.505.0, Culture=neutral, PublicKeyToken=31bf3856ad364e35"
priority="0" />
</exceptionHandlers>
</add>
</exceptionTypes>
```

```
</add>
</exceptionPolicies>
</exceptionHandling>
```

This section describes the configuration to trace out calls to TotalAgility. To output tracing, you must update the relevant CONFIG file. If tracing web server calls, edit Web.config.

- To output tracing Logger.Log() or Logger.LogMessage() calls in TotalAgility to a text file, update the relevant CONFIG file with the following:

```
....
<trace autoflush="true">
  <listeners>
    <add name="Log" type="System.Diagnostics.TextWriterTraceListener"
      initializeData="c:\temp\Trace.txt">
      </add>
    </listeners>
  </trace>
....
```

For more information, see [Logging](#).

- To output tracing about all calls being made through Unity dependency injection to a text file, update the CONFIG file with the following changes in addition to the above changes:

```
....
<unity xmlns="http://schemas.microsoft.com/practices/2010/unity">
  <container>
    <extension type="Agility.Server.Common.Logging.LogMethodRegistration,
      Agility.Server.Common, Version=1.0.0.0, Culture=neutral,
      PublicKeyToken=d86c87abe4a71948" />
  </container>
</unity>
```

TotalAgility Transformation Server

This section provides logging diagnostic information for the TotalAgility Transformation Server. The logging configuration is stored in `Kofax.CEBPM.CPUServer.ServiceHost.exe.config`.

By default, the Transformation Server configuration file is located in the temporary folder. To save the log file in another location, such as `C:\logs\TS_Log`, do the following:

1. Stop the Kofax Transformation Server service.
2. Open "Kofax.CEBPM.CPUServer.ServiceHost.exe.config" in text editor.
3. Search for "CPUServerLogTxt" and modify the section after initializeData to the path you wish to save the log file. Example:

```
<add name="CPUServerLogTxt"
  type="Kofax.CEBPM.CPUServer.Common.Diagnostics.DateTimeTaggedTraceListener,
  Kofax.CEBPM.CPUServer.Common" initializeData="C:\logs\TS_Log
  \KofaxCPUServerLog.log" >
</add>
<filter type="System.Diagnostics.EventTypeFilter" initializeData="All"/>
```

4. Restart the Kofax Transformation Server service and verify that the updated log file is written to the new directory.

You can configure logging to use different outputs, such as event log and log file. In the application configuration file, you can also specify the logging options.

Example: Log errors into the application event log

This example defines a simple logging configuration where all errors log into the application event log so they can be viewed using the Event Viewer utility.

It includes:

TraceLevelSwitch: This trace switch with a value "Verbose" traces verbose, information, warning and error messages. This switch is used for all Transformation Server modules. See the `switchName` attribute of the `<source>` tag.

initializeData="Error": This attribute specifies the tracing level in the trace listener.

```
<system.diagnostics>
  <trace autoflush="true" />
  <switches>
    <!--
      Off - None
      Error - Only error messages.
      Warning - Warning messages and error message.
      Information - Informational messages, warning messages and error messages.
      Verbose - Verbose messages, informational messages, warning messages and error
messages.
      All - All messages.
    -->
    <add name="TraceLevelSwitch" value="Verbose"/>
  </switches>
  <sources>
    <source name="Kofax.CEBPM.CPUServer.ServiceHost" switchName="TraceLevelSwitch" >
      <listeners>
        <clear />
        <add name="EventLogListener" />
      </listeners>
    </source>
    <source name="Kofax.CEBPM.CPUServer.Core" switchName="TraceLevelSwitch" >
      <listeners>
        <clear />
        <add name="EventLogListener" />
      </listeners>
    </source>
    <source name="Kofax.CEBPM.CPUServer.Common" switchName="TraceLevelSwitch" >
      <listeners>
        <clear />
        <add name="EventLogListener" />
      </listeners>
    </source>
    <source name="Kofax.CEBPM.DataLayer" switchName="TraceLevelSwitch" >
      <listeners>
        <clear/>
      </listeners>
    </source>
    <add name="xml" type="System.Diagnostics.XmlWriterTraceListener"
initializeData="Kofax.CEBPM.DataLayer.log"/>
  </sources>
  <sharedListeners>
    <add name="EventLogListener" type="System.Diagnostics.EventLogTraceListener"
initializeData="Application" >
      <filter type="System.Diagnostics.EventTypeFilter" initializeData="Error"/>
    </add>
  </sharedListeners>
</system.diagnostics>
```

Example: Logs in different formats

This example defines the logging configuration to log all messages to the text files and errors to the event log.

To have logs in different formats you must specify the Trace Listener in the <sharedListeners> section and reference it under all necessary sources in the <source> tag.

```
<system.diagnostics>
  <trace autoflush="true" />
  <switches>
    <!--
      Off - None
      Error - Only error messages.
      Warning - Warning messages and error message.
      Information - Informational messages, warning messages and error messages.
      Verbose - Verbose messages, informational messages, warning messages and error
messages.
      All - All messages.
    -->
    <add name="TraceLevelSwitch" value="Verbose"/>
  </switches>
  <sources>
    <source name="Kofax.CEBPM.CPUServer.ServiceHost" switchName="TraceLevelSwitch" >
      <listeners>
        <clear />
        <add name="CPUServerLogTxt" />
        <add name="EventLogListener" />
      </listeners>
    </source>
    <source name="Kofax.CEBPM.CPUServer.Core" switchName="TraceLevelSwitch" >
      <listeners>
        <clear />
        <add name="CPUServerLogTxt" />
        <add name="EventLogListener" />
      </listeners>
    </source>
    <source name="Kofax.CEBPM.CPUServer.Common" switchName="TraceLevelSwitch" >
      <listeners>
        <clear />
        <add name="CPUServerLogTxt" />
        <add name="EventLogListener" />
      </listeners>
    </source>
    <source name="Kofax.CEBPM.DataLayer" switchName="TraceLevelSwitch" >
      <listeners>
        <clear/>
        <add name="xml" type="System.Diagnostics.XmlWriterTraceListener"
initializeData="Kofax.CEBPM.DataLayer.log"/>
      </listeners>
    </source>
  </sources>
  <sharedListeners>
    <add name="CPUServerLogTxt"
type="System.Diagnostics.TextWriterTraceListener "
initializeData="KofaxCPUServerLog.log" >
<filter type="System.Diagnostics.EventTypeFilter" initializeData="All"/>
    </add>
    <add name="EventLogListener"
type="System.Diagnostics.EventLogTraceListener" initializeData="Application" >
<filter type="System.Diagnostics.EventTypeFilter" initializeData="Error"/>
    </add>
```

```
</sharedListeners>  
</system.diagnostics>
```

Transformation Server has its own internal trace listener, `DateTimeTaggedTraceListener` which allows to have a text log with timestamps in different formats.

Optionally, you can specify different trace switches and assign them to different trace sources. For example, you can log all messages from `Kofax.CEBPM.CPUServer.Core` and log only errors from `Kofax.CEBPM.CPUServer.Common`.

For more information on tracing and tracing options, refer to Microsoft documentation available at the Microsoft website.

Example: Text log with timestamps in different formats

This example defines the configuration of `DateTimeTaggedTraceListener`.

```
<!--  
    initializeData for DateTimeTaggedTraceListener should have the following  
    format:  
        initializeData="<file name>;<format>"  
        or initializeData="<file name>"  
  
    where:  
        <file name> is the log file name;  
        <format> is the desired date time format;  
  
    If <format> is not specified, the default format, "MM/dd/yyyy hh:mm:ss.fff tt" is  
    used.  
For more information on date time format strings, refer to Microsoft documentation at  
the Microsoft web site.  
-->  
<add name="CPUServerLogTxt"  
    type="Kofax.CEBPM.CPUServer.Common.Diagnostics.DateTimeTaggedTraceListener,  
Kofax.CEBPM.CPUServer.Common" initializeData="KofaxCPUServerLog.log" >  
<filter type="System.Diagnostics.EventTypeFilter" initializeData="All"/>  
</add>
```

Data Layer

This section provides information on configuring error logging for the Data Layer.

The Data Layer uses the standard .NET logging. The logging configuration is stored in `TotalAgility Web.config`, `Agility.Server.Core.WorkerService.exe.config` and `Kofax.CEBPM.CPUServer.ServiceHost.exe.config`.

You can configure logging to use different outputs, such as event log and log file.

Multiple trace sources include:

- **Kofax.CEBPM.DataLayer:** The main Data Layer trace source that contains majority of the important log statements.
- **Kofax.CEBPM.DataLayer.Nhibernate:** The Supplementary NHibernate logging that contains a lot of information. Use with care.
- **Kofax.CEBPM.DataLayer.Imaging:** Contains information about the image processing operations.

- **Kofax.CEBPM.DataLayer.PdfLibrary:** Contains information about the PDF related operations.

Example: Logging configuration

```
<?xml version="1.0" encoding="utf-8" ?>
<configuration>
  <system.diagnostics>
    <trace autoflush="true"/>
    <sources>
      <!-- Main Data Layer trace source - contains majority of important log statements -->
      <source name="Kofax.CEBPM.DataLayer" switchValue="Warning">
        <listeners>
          <clear/>
          <add name="DataLayerAll"/>
        </listeners>
      </source>
      <!-- Supplementary NHibernate logging, use with care - it contains a LOT of information -->
      <source name="Kofax.CEBPM.DataLayer.NHibernate" switchValue="Warning">
        <listeners>
          <clear/>
          <add name="DataLayerAll"/>
        </listeners>
      </source>
    </sources>
    <sharedListeners>
      <add name="DataLayerAll" initializeData="Kofax.CEBPM.DataLayer.log"
      type="System.Diagnostics.XmlWriterTraceListener"/>
    </sharedListeners>
  </system.diagnostics>
</configuration>
```

Capture Client

This section provides information on configuring error logging for Capture Client.

Capture Client uses the standard .NET logging. The logging configuration is stored in TotalAgility Web.config.

You can configure logging to use different outputs, such as event log and log file.

Example: Logging configuration

```
<system.diagnostics>
  <switches>
    <add name="DocumentServicesTraceLevelSwitch" value="All" />
  </switches>
  <sharedListeners>
    <!-- Event log trace listener. By default write only errors. -->
    <add name="EventLogListener" type="System.Diagnostics.EventLogTraceListener"
    initializeData="TotalAgility">
      <filter type="System.Diagnostics.EventTypeFilter" initializeData="Error" />
    </add>
    <!-- Simple text log for Document Services -->
    <add name="DocumentServicesTxt" initializeData="c:\temp\tc.log"
    type="System.Diagnostics.TextWriterTraceListener">
      <filter type="System.Diagnostics.EventTypeFilter" initializeData="All" />
    </add>
```



```

</sharedListeners>
<sources>
  <source name="Kofax.CEBPM.ThinClient.DocumentServices"
switchName="DocumentServicesTraceLevelSwitch">
    <listeners>
      <clear />
      <add name="EventLogListener" />
      <add name="DocumentServicesTxt" />
    </listeners>
  </source>
</sources>
<trace autoflush="true">
  <listeners>
  </listeners>
</trace>
</system.diagnostics>

```

Where,

- **traceOutputOptions:** Defines the additional data to each log statement (DateTime, ThreadId).
- **type:** Defines the type of logging, such as text file.
- **initializeData:** Defines the path to the log file.
- **(Filter) initializeData:** Defines the trace level (Off, Critical, Error, Warning, Information, Verbose or All).

TotalAgility Reporting Server

This section provides logging diagnostic information for the TotalAgility Reporting Server. The logging configuration is stored in the Kofax.CEBPM.Reporting.TAService.exe.config and Kofax.CEBPM.Reporting.AzureETL.exe.config files.

The logging mechanism is similar to Transformation Server or Data Layer that uses the Microsoft .NET diagnostics. The source name for the Reporting messages is "Reporting".

By default, both the files use customized trace listener Kofax.Reporting.Common.Logging.TenantBasedTraceListener. This listener allows automatic separation of logs by tenant and supports circular logging via configurable parameters: `maxFileSizeKB` and `maxFilesAmount`.

The following XML displays the System.Diagnostics sections from Kofax.CEBPM.Reporting.AzureETL.exe.config and Kofax.CEBPM.Reporting.TAService.exe.config.

Example: System.Diagnostics in Kofax.CEBPM.Reporting.AzureETL.exe.config

```

<system.diagnostics>
  <trace autoflush="true"/>
  <switches>
    <add name="TraceLevelSwitch" value="Warning"/>
  </switches>
  <sources>
    <source name="Reporting" switchName="TraceLevelSwitch">
      <listeners>
        <clear/>
        <add name="TextDiagnostics"/>
      </listeners>
    </source>
  </sources>

```

```

</sources>
<sharedListeners>
  <!--Using customized Listener which can generate log file name based on tenant
  name (if used {0} placeholder in the name).
  By default, logs folder is C:\ProgramData\Kofax\TotalAgility\Reporting\Log-->
  <add name="TextDiagnostics"
  type="Kofax.Reporting.Common.Logging.TenantBasedTraceListener,
  Kofax.Reporting.Common"
  initializeData="C:\ProgramData\Kofax\TotalAgility\Reporting\Log\ETLApp_{0}.log"
  maxFileSizeKB="5120" maxFilesAmount="10">
  </add>
</sharedListeners>
</system.diagnostics>

```

Example: System.Diagnostics in Kofax.CEBPM.Reporting.TAService.exe.config

```

<system.diagnostics>
  <trace autoflush="true"/>
  <switches>
    <add name="TraceLevelSwitch" value="Warning"/>
  </switches>
  <sources>
    <source name="Reporting" switchName="TraceLevelSwitch">
      <listeners>
        <clear/>
        <add name="ReportingLogTxt"/>
      </listeners>
    </source>
  </sources>
  <sharedListeners>
    <!--By default logs folder is C:\ProgramData\Kofax\TotalAgility\Reporting\Log-->
    <add name="ReportingLogTxt"
    type="Kofax.Reporting.Common.Logging.TenantBasedTraceListener, Kofax.Reporting.Common"
    initializeData="C:\ProgramData\Kofax\TotalAgility\Reporting\Log\WorkerRole.log"
    maxFileSizeKB="5120" maxFilesAmount="10">
      <filter type="System.Diagnostics.EventTypeFilter" initializeData="All"/>
    </add>
  </sharedListeners>
</system.diagnostics>

```

You can do the following:

- Change the logging detalization by changing the "TraceLevelSwitch" value to any of the following values: Off, Critical, Error, Warning, Information, Verbose, All.
- Change the location of the log file by modifying the value of the "initializeData" attribute of the "ReportingLogTxt" shared listener. The default path for the log files is "ReportingLogTxt".
- Change the number of files used with circular logging by modifying the value of "maxFilesAmount". When the value is less than 2, default value of 10 is used. The "maxFileSizeKB" parameter allows to configure the maximum size of logging file per each file used in circular logging. The logging files have the index number at the end of file name.

Client-side reporting

You can enable logging in the Reporting client-side library that is used in the TotalAgility components to report data into Reporting Server.

To enable the Reporting client-side logging for these components, you must extend the existing System.Diagnostics section of TotalAgility Web.config, Agility.Server.Core.WorkerService.exe.config

and Kofax.CEBPM.CPUServer.ServiceHost.exe.config with the following switches, sources and shared listeners.

Example: System.Diagnostics changes for the client-side reporting

```
<system.diagnostics>
  <trace autoflush="true"/>
  <switches>
    <add name="TraceLevelSwitch" value="Verbose"/>
  </switches>
  <sources>
    <source name="Reporting" switchName="TraceLevelSwitch">
      <listeners>
        <clear/>
        <add name="ReportingLogTxt"/>
      </listeners>
    </source>
  </sources>
  <sharedListeners>
    <add name="ReportingLogTxt" type="System.Diagnostics.TextWriterTraceListener,
system, version=1.0.3300.0, Culture=neutral, PublicKeyToken=b77a5c561934e089"
initializeData="Kofax.Reporting.Integration.log" />
  </sharedListeners>
</system.diagnostics>
```

We recommend that you use different log names in different Application configuration files if they are modified on the same machine.

For example, use `initializeData="Kofax.Reporting.Integration_web.log"` for Web.config, and `initializeData="Kofax.Reporting.Integration_CPU_server.log"` for the Transformation Server.

This will prevent mixing information logged by different instances of client-side library in one file.

Web Capture logging

You can enable the javascript logs using the browser console by setting the following parameter:

```
Atalasoftware.TraceEnabled = true
```

You can enable the Web Capture Service logging using the following configuration files:

- Kofax.WebCapture.Host.exe.log.config
- Kofax.WebCapture.ScanWorker.exe.log.config

To log all statements, set the following parameters:

```
DisableLogging=false
Filter="%Severity% >= trace"
```

Available log levels are trace, debug, info, warning, error and fatal.

Network logging

The third party utilities, Fiddler and Wireshark, and developer tools built into the various browsers offer useful features to trace out HTTP requests.

Such utilities enable you to troubleshoot potential network issues.

License Server logging

You can enable custom logging for the license server by adding the following parameters to win.ini available at C:\Windows.

```
[KDB]
File=On
filename=C:\licensedebug.log
```

KFXConverter

This section describes KFXConverter logging information. The log contains information about all the tasks performed by KFXConverter, and error information about the errors that occur while converting the files.

The default name of the log file is KFXConverter.log. The default location is C:\ProgramData\Kofax\KFXConverter. The maximum log file size is 5 MB. The file is overwritten when the maximum size is reached. You can specify another log file using the command line option `-logFile <path>\<filename>`. For example, `-logFile C:\temp\mylog.log`.

For PDF/A normalization using the **Standard** option in the **PDF to PDF/A conversion engine** in Message Connector, conversion results are logged in StandardPDFEngine_<GUID>.log. This log file contains information about the PDF/A conversion using the Standard PDF to PDF/A conversion engine. However, this file is deleted if conversion is successful.

Message Connector

This section describes the Message Connector logging information. The log file contains information about the connections established by Message Connector and error information about failed connections. By default, the Message Converter log file is available at C:\ProgramData\Kofax\KIC-ED\MC\Log.

The location of Message Connector installation logs depend upon how Message Connector is installed:

- If Message Connector is installed using the setup.exe, the logs are saved at C:\ProgramData\temp\MC\<instance_number>.
- If Message Connector is installed using the .msi file, the logs are saved at C:\ProgramData\temp.

To manage Message Connector logging:

1. Open Message Connector Configuration from the **Kofax** group in the Windows Start menu.
2. Click **Advanced** to display additional configuration options.
3. Expand **Trace settings**.

4. Edit the settings on the **Trace settings** tab.
 - The default values (TraceLevel 10 and MessageTraceSize 1) provide basic trace information (that is often sufficient) without negatively impacting performance.
 - Troubleshooting values (TraceLevel 40 and MessageTraceSize 100000) provide a lot of information; these are more suitable when duplicating error situations in a controlled environment.

Refer to the *Message Connector Help* for more information on parameters.

5. Click **Save** and then click **Exit**.

Document Converter

This section describes the Kofax Document Converter logging information. The log contains information about all the tasks performed by Document Converter and error information about the errors that occur while converting the files.

The default name of the log file is KofaxDocumentConverter_<randomnumericstring>.log. The default location is C:\ProgramData\Kofax\DocumentConverter\Trace.

To manage Document Converter logging:

1. Start Document Converter Configuration from the Kofax Import Connector group in the Windows Start menu.
2. Click **Advanced** to display additional configuration options.
3. Expand **Trace settings**.
4. Edit the settings in the **Trace settings** tab.
 - The default values (TraceLevel 10 and MessageTraceSize 1) provide basic trace information (that is often sufficient) without negatively impacting performance.
 - Troubleshooting values (TraceLevel 40 and MessageTraceSize 100000) provide a lot of information; these are more suitable when duplicating error situations in a controlled environment.
5. Click **Save** and then click **Exit**.

Appendix G

Performance counter usage

The Performance Counters are used to record application states and activities. Many are already included as part of the Windows operating system, and additional counters may be created programmatically. Counters are written and placed in an application where specific measurements need to be made, such as rate of throughput, count of items and others.

Once the counters are installed on a target system, an application can write values to them. These values can then be read in real-time using the Windows Performance Monitor, a Microsoft Management Console (MMC) snap-in.

TotalAgility has a number of Performance Counters; the placement of these within the application are used to measure Key Performance Indicators (KPIs) of a number of critical services which are detailed below.

Before using the TotalAgility Performance Counters, see the following guides for more information on TotalAgility internals:

- *Kofax TotalAgility Features Guide* (see **System > System settings > System > Thread pools**)
- *Kofax TotalAgility Architecture Guide*

Installation

The Performance Counters are automatically installed on the target machine when the following services are installed:

- CoreWorker Service
- Export Service

The installation requires no input from the user.

Data collection

The Performance Counter data is collected using the Microsoft Performance Monitor. When the monitor is launched, the installed counters can be selected and added to the current monitoring session.

Interpretation

Many factors, such as hardware specifications, network topology, virtualization, nature and quantity of work being processed, and the deployment configuration of TotalAgility influence TotalAgility performance. Performance counters therefore should be viewed as indicative and used in conjunction with other approaches, such as logging and monitoring, to determine system health.

The most likely scenario of using the Performance Counters is the TotalAgility deployment that is operating a heavy load. In this case, counters indicate several things:

- Some counters, such as locked automatic activities, should always be at their maximum value (as set by configuration). Dips in performance can indicate contention, overloading, network issues, and more.
- Some worker tasks, such as the Archive Jobs Worker, are executed according to a configurable schedule. The associated counter should reflect this scheduled activity; any other result indicates that the system is not performing as expected.
- Thread pools and thread pool queue counters can indicate if long-running tasks are blocking execution and require scaling.

Locked automatic activities

This counter indicates the number of automatic activities taken up by TotalAgility to execute from the TotalAgility database. This number corresponds to the `MaximumNumberOfActivitiesToLock` setting in the `CoreWorker` configuration file, which has a factory value of 32. This counter should be used in conjunction with other counters, such as the thread pool queues, to determine if the system is efficiently servicing the tasks. If queues are not being serviced in a timely manner, possible remediation includes reducing the `MaximumNumberOfActivitiesToLock` value and / or increasing the thread pool size. Counters are available for the following services:

- CoreWorker Service
- Export Service

Worker tasks taken

This counter indicates the number of job-related worker tasks of each type that are due to be processed. These tasks are performed in the job and process activities thread pools, whose sizes are governed by the relevant thread pool sizes in the TotalAgility System Settings. Counters are available for the following worker task types:

- Archive Jobs Worker
- Create Exceptions Worker
- Create Jobs Worker
- Evaluate Jobs Worker
- Process Activity Worker
- Process Capture Timeouts Worker
- Process State Actions Worker

A consistently high reading here may indicate that the thread pool value needs to be increased, although this requires experimentation to find the best value for any given scenario. Counters are available for the CoreWorker service.

Active threads / Thread pools

This counter indicates the number of active threads per thread pool for the CoreWorker service. A consistently high reading here may indicate that scaling may need to be considered to accommodate the workload, either horizontal or vertical. Counters are available for the CoreWorker service.

Items / Thread pool queue

This counter indicates the number of items queued in the CoreWorker service thread pool and waiting to be added. A consistently high reading may indicate that scaling is required to accommodate the workload, either horizontal or vertical. Counters are available for the following services:

- CoreWorker Service
- Export Service

Uninstall

The Performance Counters are automatically uninstalled on the target machine when the following services are stopped:

- CoreWorker Service
- Export Service

The uninstallation requires no input from the user.

Logging

In general, Performance Monitor samples the performance counters every one second. While this provides sufficient information for most purposes, some scenarios may require a deeper level of detail which can be viewed in the log file. You can log each performance counter in the TotalAgility log file by enabling the logging function.

Enable logging in the Core Worker Service and Export Worker Service configuration files as follows:

1. Open `Agility.Server.Core.WorkerService.exe.config` and `Agility.Server.Core.ExportService.exe.config` located in the `CoreWorkerService` folder available at your installation location, for example, `C:\Program Files\Kofax\TotalAgility\CoreWorkerService`
2. Under the `<appSettings>` section, change the following value to **true**:
`<add key="PerformanceLoggingEnabled" value="false"/>`
3. Uncomment the **<system.diagnostics>** section in the service configuration files:

```
<system.diagnostics>
  <trace autoflush="true" indentsize="4">
    <listeners>
      <add name="KTALog" type="System.Diagnostics.TextWriterTraceListener"
initializeData="c:\temp\KTALog.txt">
      </add>
    </listeners>
  </trace>
</system.diagnostics>
```

i Disable logging once finished, as continuous use will cause an unnecessary increase in the size of the log file.

Appendix H

Supported input and output file formats

This chapter provides information about the input and output formats supported for conversion.

Supported formats for document normalization

TotalAgility supports the following document formats for conversion with various third-party tools.

	Microsoft Office	Apache OpenOffice.org / LibreOffice	Total HTML ConverterX	Third-party tools used in Message Connector	KFXConverter
Word documents ^{1,7}	Yes	Yes		Yes	Yes
Excel documents ^{1,7}	Yes	Yes		Yes	Yes
PowerPoint documents ^{1,7}	Yes	Yes		Yes	Yes
Text documents (both attachments and email body)	Yes	Yes		Yes	Yes
OpenOffice documents		Yes			Yes
HTML, MHT documents (both attachments and email body)	Yes		Yes	Yes	Yes
EML documents (email header embedded on the first page of email body) ⁵				Yes	Yes
MSG documents ^{3,5}				Yes	Yes
PST files ⁵				Yes	Yes
PDF documents, including portfolio PDFs ^{1,2}				Yes	Yes
Compressed documents (ZIP, RAR, 7Z, TAR, TZ,GZIP) ¹				Yes	Yes

	Microsoft Office	Apache OpenOffice.org / LibreOffice	Total HTML ConverterX	Third-party tools used in Message Connector	KFXConverter
XML documents ⁶				Yes	
XML Paper Specification (XPS) ⁷ and OXPS					Yes
VCF					Yes

1. Conversion of password-protected documents is not supported.
2. Conversion of PDF documents with XFA forms (Adobe XML Forms Architecture) created with Adobe Experience Manager Designer requires Adobe Experience Manager environment via network.
3. MSG documents where attachments are removed by any Microsoft Outlook archiving function are not supported and they are treated as document conversion errors.
4. Require additional manual steps. See Convert PST files in *Kofax TotalAgilityAdministrator's Guide*.
5. For folder import only, EML and MSG files are treated as if the messages have arrived via email. The metadata of the message (and not the metadata of the file) is used.
6. Conversion might require third-party tools during configuration or customization. The tools are not required during operation.
7. KFXConverter supports conversion of Microsoft Office 2016 to Microsoft Office 2021 and Microsoft Office 365 documents. It also supports the conversion of XPS format.

 Each conversion tool produces the desired output in a different way. As a result, switching to another conversion tool may change the look of your converted documents.

Supported formats for document conversion

TotalAgility supports the following document formats for conversion with various third-party tools.

 You cannot use MS Office, Open Office, or Total HTML Converter in an Azure environment.

Document formats	Microsoft Office	OpenOffice.org	Total HTML ConverterX	Third-party tools used in Document Converter	KFXConverter
Word documents (DOC, DOCX, DOT, DOTM, DOTX, and DOCM) ^{1, 9}	Yes	Yes (DOC and DOCX formats only)		Yes	Yes

Document formats	Microsoft Office	OpenOffice.o	Total HTML ConverterX	Third-party tools used in Document Converter	KFXConverter
Excel documents (XLS, XLSX, XLM, XLT, XLSM, XLTX, XLTM, XLSB, XLAM and CSV) ^{1,9}	Yes	Yes (XLS and XLSX formats only)		Yes	Yes
PowerPoint documents (PPT, PPTX, POT, PPTM, POTX, POTM, PPS, PPSX, PPSM, SLDX, and SLDM) ^{1,4,9}	Yes	Yes (PPT and PPTX formats only)		Yes	Yes
Text documents (both attachments and email body) (TXT, LOG, RTF, and XPS)	Yes	Yes		Yes	Yes
OpenOffice documents (ODP, OTP, STI, SXI, ODG, OTG, STD, SXD, ODT, OTT, STW, SXW, ODS, OTS, STC, and SXC)		Yes			Yes (ODT, ODS, and ODP formats only)
HTML, MHT, HTM, MHTML documents (both attachments and email body)	Yes		Yes	Yes	Yes
EML documents (email header embedded on the first page of email body) ⁷				Yes	Yes
MSG documents ^{5,7}				Yes	Yes
PST files ⁶				Yes	Yes
Images (BMP, GIF, JPG, JPEG, PNG, TIF, HEIF, HEIC, JFIF, and TIFF) ²				Yes	Yes
PDF documents (including portfolio PDFs and XFA) ^{3,10}				Yes	Yes
compressed documents (ZIP, RAR, 7Z, TAR, and GZ) ¹				Yes	Yes
XML documents ⁸				Yes	
XML Paper Specification (XPS) and OXPS ⁹					Yes
VCF					Yes

1. Conversion of password-protected documents is not supported.
2. Images can be converted to the 200x200 dpi or 300x300 dpi resolutions; black & white, grayscale, or color.

3. Conversion of PDF documents with XFA forms (Adobe XML Forms Architecture) created with Adobe Experience Manager Designer requires Adobe Experience Manager environment via network.
4. Conversion of PowerPoint documents with the extension .ppsx is not supported via OpenOffice.org.
5. MSG documents where attachments are removed by any Microsoft Outlook archiving function are not supported and they are treated as document conversion errors.
6. Require additional manual steps. See Import PST files in *Kofax TotalAgility Administrator's Guide*.
7. For folder import only, EML and MSG files are treated as if the messages have arrived via email. The metadata of the message (and not the metadata of the file) is used.
8. Conversion might require third-party tools during configuration or customization. The tools are not required during operation.
9. KFXConverter supports conversion of Microsoft Office 2016 to Microsoft Office 2021 and Microsoft Office 365 documents. It also supports the conversion of XPS format.
10. Conversion of password-protected PDF portfolio is not supported.

i Each conversion tool produces the desired output in a different way. As a result, switching to another conversion tool may change the look of your converted documents.

Attachment Encoding

Kofax Import Connector understands attachments with the following Content-Transfer-Encoding types:

- Base64
- Quoted-printable
- Uuencode/x-uuencode

i Xxencode encoding is not supported.

Input and output formats for a Document Converter

The following table illustrates the input and respective output formats supported by Document Converter.

Input file format	Output file formats		
	TIFF	PDF	PDF/A ⁶
MSG, EML	✓	✓	✓
MS Office documents ^{1, 2, 3}	✓	✓	✓
CSV	✓	✓	✓

Input file format	Output file formats		
	TIFF	PDF	PDF/A ⁶
TXT, LOG, RTF, XPS, and OXPS	✓	✓	✓
OpenOffice ⁴	✓	✓	✓
HTML	✓	✓	✓
MIME HTML (MHT)	✓	✓	✓
PDF (1.2 - 1.7)	✓	×	✓
XML ⁵	✓	✓	✓
GIF, JPEG, PNG, HEIF, HEIC, BMP, and JFIF	✓	×	×
VCF	✓	✓	✓

1. DOC, DOCX, DOCM, DOT, DOTX
2. XLS, XLSX, XLM, XLSM, XLT, XLTX, XLTM, XLSB, XLAM
3. PPT, PPTX, PPTM, POT, POTX, POTM, PPS, PPSX, PPSM
4. ODP, OTP, STI, SXI, ODG, OTG, STD, SXD, ODT, OTT, STW, SXW, ODS, OTS, STC, SXC, SLDX, SLDM
5. Requires a matching XSLT that converts to HTML which is then converted to PDF.
6. PDF/A-1a, PDF/A-1b, PDF/A-2a, PDF/A-2b, PDF/A-2u, PDF/A-3a, PDF/A-3b, PDF/A-3u

For more information about input formats and specific PDF (PDF and PDF/A) formats, see [Supported input formats and output PDF formats](#).

Input and output formats for a Message Connector

The following table illustrates the supported input formats and respective output formats.

Input file formats	Output file formats		
	TIFF	PDF	PDF/A ⁶
BMP, GIF, JPEG, PNG, TIFF, HEIF, HEIC, and JFIF	✓	✓	✓
MSG, EML	✓	✓	✓
MS Office documents ^{1, 2, 3}	✓	✓	✓
CSV	✓	✓	✓
TXT, LOG, RTF, XPS, and OXPS	✓	✓	✓
OpenOffice ⁴	✓	✓	✓
HTML	✓	✓	✓
MIME HTML (MHT)	✓	✓	✓

Input file formats	Output file formats		
	TIFF	PDF	PDF/A ⁶
PDF (1.2 - 1.7)	✓	×	✓
VCF	✓	✓	✓
XML ⁵	✓	✓	✓

1. DOC, DOCX, DOCM, DOT, DOTX, DOCM, MPP, ONE, VSD

 The .mpp files created using Microsoft Project 98 or earlier are not supported by Aspose.

2. XLS, XLSX, XLM, XLSM, XLT, XLTX, XLTM, XLSB, XLAM
3. PPT, PPTX, PPTM, POT, POTX, POTM, PPS, PPSX, PPSM
4. ODP, OTP, STI, SXI, ODG, OTG, STD, SXD, ODT, OTT, STW, SXW, ODS, OTS, STC, SXC, SLDX, SLDM
5. Requires a matching XSLT that converts to HTML which is then converted to PDF.
6. PDF/A-1a, PDF/A-1b, PDF/A-2a, PDF/A-2b, PDF/A-2u, PDF/A-3a, PDF/A-3b, PDF/A-3u

For more information about input formats and specific PDF (PDF and PDF/A) formats, see [Supported input formats and PDF output formats](#).

Supported input formats and PDF output formats

The following table provides a list of all the input file formats supported by KFXConverter and the respective output (PDF or PDF/A) formats.

Input file formats	Output PDF formats	Output PDF/A formats
DOC, DOCX, DOCM, DOT, DOTX, ODT	PDF 1.5	PDF/A-1a PDF/A-1b
XLS, XLSX, XLM, XLT, XLTX, XLSB, XLAM, CSV, ODS	PDF 1.4	PDF/A-2a PDF/A-2b
PPT, PPTX, PPTM, POTX, ODP	PDF 1.5	PDF/A-2u
MPP, ONE, VSD	PDF 1.4	PDF/A-3a PDF/A-3b PDF/A-3u
 The .mpp files created using Microsoft Project 98 or earlier are not supported by Aspose.		
MHT file	PDF 1.5	
HTML, HTM	PDF 1.5	
PDF-1.2 to PDF-1.7	Not supported	

Input file formats	Output PDF formats	Output PDF/A formats
TXT, Log	PDF 1.5	
OXPS	PDF 1.4	

If the content of the input PDF file does not meet the criteria to be converted to the required PDF/A format, the format of the output PDF/A may be downgraded.

 This applies only to the files which are convertible to a PDF/A compliant file.

For example:

- If the input file contains text that is not extractable and the output is configured to PDF/A-2u, the actual output will be downgraded to PDF/A2b.
- If the input does not contain logical structure information (that is, tagging) and the output is configured to PDF/A1a, the actual output will be downgraded to PDF/A1b.

The following table summarizes the configured output in TotalAgility, the expected PDF/A format of the output file, and the actual PDF/A format of the output file based on the contents of the input file.

Input PDF version	Configured PDF/A format for output	Expected PDF/A format of the output	Actual PDF/A format of output in case of a downgrade	Output PDF version
PDF version 1.3	PDF/A-1a	PDF/A-1a	PDF/A-1b	1.4
PDF version 1.5	PDF/A-1b	PDF/A-1b	PDF/A-1b	1.4
PDF version 1.6	PDF/A-2a	PDF/A-2a	PDF/A-2u	1.7
PDF version 1.7	PDF/A-2b	PDF/A-2b	PDF/A-2b	1.7
PDF version 1.8	PDF/A-2u	PDF/A-2u	PDF/A-2u	1.7
	PDF/A-3a	PDF/A-3a	PDF/A-3u	1.7
	PDF/A-3b	PDF/A-3b	PDF/A-3u	1.7
	PDF/A-3u	PDF/A-3u	PDF/A-3u	1.7