



Tungsten TotalAgility Features Guide

Version: 8.1.0

Date: 2024-10-01

TUNGSTEN
AUTOMATION

© 2024 Tungsten Automation. All rights reserved.

Tungsten and Tungsten Automation are trademarks of Tungsten Automation Corporation, registered in the U.S. and/or other countries. All other trademarks are the property of their respective owners. No part of this publication may be reproduced, stored, or transmitted in any form without the prior written permission of Tungsten Automation.

Table of Contents

Preface.....	11
TotalAgility documentation.....	11
Introduction to TotalAgility.....	11
On-Premise Multi-Tenancy.....	11
Tungsten Analytics for TotalAgility.....	12
Training.....	12
Getting help with Tungsten Automation products.....	12
Chapter 1: Imaging.....	14
Chapter 2: Transformation.....	15
Classification.....	15
Trainable Document Separation.....	15
Clustering.....	15
Extraction from unstructured documents.....	16
Extraction from invoices.....	16
Extraction from forms.....	16
Extraction from tables.....	16
Extraction – check processing.....	16
Extraction from key-value pairs.....	16
Extraction from the document library.....	17
Auto Extract.....	17
Database extraction.....	17
Extraction - other.....	17
Optical Character Recognition (OCR).....	17
Recognition engines.....	17
Bar code recognition.....	18
Natural language processing.....	19
Named Entity Locator.....	19
Sentiment Locator.....	19
Summary Locator.....	19
Themes Locator.....	20
Tungsten Search and Matching Server.....	20
Chapter 3: Case and business process modeling.....	21
Business Process Modeling Notation (BPMN).....	21
Start node.....	21
Event types for a start node.....	21

Activity.....	22
Annotation.....	22
Attachment.....	22
End node.....	23
Process paths.....	23
Decision.....	23
Branching rules.....	24
Dependents.....	25
Preconditions.....	25
Loop.....	26
Manage process maps.....	26
Variables.....	27
Process variable examples.....	27
Initialization variables.....	27
Variable types.....	28
Activity types.....	32
Common activities.....	32
Capture activities.....	37
Tungsten activities.....	43
Microsoft activities.....	45
CMIS activities.....	48
OpenText activities.....	49
Script activities.....	50
Other activities.....	53
Custom service activity.....	58
Activity input and output.....	58
Service level agreement.....	59
Time and cost.....	60
Time and cost for a process.....	60
Time and cost for an activity.....	60
Milestones.....	62
States.....	63
Restart action.....	63
Event action.....	64
New Job action.....	64
Process events.....	64
Notes.....	65
Data models.....	65

Document set.....	66
Roles.....	66
Types of roles.....	67
Resource assignment.....	68
Static versus dynamic resources.....	68
Manual allocation versus dynamic allocation.....	69
Assign resources by applying rules.....	70
Communicate with resources.....	71
Activity notification.....	71
Resource notes.....	71
Alerts.....	72
Triggers.....	72
Trigger types.....	72
Trigger creation.....	72
Process triggers.....	73
Milestone triggers.....	74
Activity triggers.....	75
Predictive model.....	76
Access.....	77
Maintenance access.....	77
Default settings.....	78
Activity defaults.....	78
Activity notification defaults.....	78
Process variables.....	78
Case completion.....	79
History, reporting and execution.....	79
History.....	79
Reporting.....	80
Execution.....	80
Exceptions.....	80
Process associations.....	81
Process documentation.....	82
Test plan.....	82
Case definitions.....	83
Fragments.....	83
Process versus case.....	83
Business rules.....	84
Business rule types.....	84

Skins.....	89
Templates.....	89
Rules.....	89
Custom services.....	90
System processes.....	90
SYSTEM Active Directory Synchronization.....	90
SYSTEM Check for Completed Delegations.....	90
SYSTEM Passcode Notification.....	91
SYSTEM Perform Auto Work Allocation.....	91
System Process Email Activity.....	91
SYSTEM Reset Password.....	92
SYSTEM Reset Quantity Counts.....	92
Save and release processes.....	93
Revert and delete processes.....	93
Revert processes.....	93
Delete processes.....	93
Monitoring.....	94
Business events.....	94
Business alerts.....	94
Business targets.....	94
Chapter 4: Model the user interface.....	95
Generate forms automatically.....	95
Manually create forms.....	96
Toolbox.....	97
Layout.....	98
General controls.....	98
Input types.....	100
Headings.....	100
Advanced controls.....	101
Form initialization.....	109
Form events and actions.....	109
Form actions.....	109
Form events.....	112
Form variables.....	124
Form variable types.....	125
Deploy forms.....	125
Form debugging.....	125
Associate a form with an activity.....	125

Sites.....	126
Themes.....	126
Global variables.....	126
Security tokens.....	127
Navigations.....	127
Customer assets.....	128
Form variants.....	128
Chapter 5: Workspace.....	129
Create work.....	129
Create jobs, cases and fragments.....	129
Job or case properties.....	129
Find jobs or cases.....	129
Manage work.....	129
Work queues.....	129
Queries panel.....	130
Take and complete activities.....	130
Delegate work.....	130
Reassign work.....	130
Manual work allocation.....	130
Reset taken activities.....	130
Modify live jobs and activities.....	131
Place jobs on hold.....	131
Business calendar.....	131
Manage your system.....	131
Logged on users.....	131
Audit log.....	131
Upgrade jobs.....	132
Remove finished jobs.....	132
Performance statistics.....	132
Management Console.....	132
Chapter 6: Resources in TotalAgility.....	133
Individual resource.....	133
Group resources.....	133
External resources.....	134
Email address.....	134
Password.....	134
Personas.....	134
Resource extensions.....	134

Working group.....	135
Supervisors.....	135
Security levels.....	135
Skill levels.....	135
Variable and fixed costs.....	135
Active period.....	136
Working category.....	136
Active Directory Synchronization.....	136
Chapter 7: System data.....	137
Server variables.....	137
Predefined server variables.....	137
Regular expressions.....	140
Lookups.....	141
Document templates.....	142
Currency codes.....	142
Error codes.....	142
Checklist templates.....	143
Checklist items.....	144
Work types.....	145
Tags.....	146
Data models.....	146
Chapter 8: Capture.....	147
Extraction groups.....	147
Classification groups.....	148
Folders.....	148
Document and activity variants.....	148
Document variants.....	148
Use case: Create variants for document types.....	149
Activity variant.....	149
Use case: Create activity variants for the Invoice document variant.....	150
Additional information about variants.....	151
Field formatters.....	151
Field validators.....	152
Field zoom settings.....	152
Document conversion profiles.....	152
PDF profiles.....	153
Scan/VRS profiles.....	153
Interaction of Scan/VRS profiles and Web Capture service with VRS Elite.....	153

Using Scan/VRS profile for MFP scanning.....	153
Separation profiles.....	154
Bar code and patch code profiles.....	154
Control layouts.....	154
Chapter 9: Translation.....	156
Chapter 10: Queries.....	158
Chapter 11: System.....	159
Categories.....	159
Job schedules.....	160
Deployment servers.....	160
Deployment schedules.....	160
System settings.....	161
Database, retention and reporting.....	161
Utilities.....	166
Process.....	167
Logon and authentication.....	169
System.....	173
User behavior.....	185
License servers and statistics.....	193
Capture.....	193
Apps.....	194
Access settings.....	194
Access control list.....	194
Additional settings.....	195
Database, retention and reporting.....	195
Utilities.....	196
Logon and authentication.....	196
Capture.....	197
Apps.....	198
GitHub.....	198
GitHub file manager.....	199
Chapter 12: Packages.....	200
Miscellaneous files.....	202
Solution rollback.....	202
Patch package.....	203
Chapter 13: TotalAgility Apps.....	204
Chapter 14: Generative AI.....	205
Chapter 15: Testing.....	206

Chapter 16: Integrate with other systems.....	207
Web service references.....	207
.Net assemblies.....	208
RPA.....	208
Custom service groups.....	208
Insight.....	208
SignDoc.....	208
TCM.....	209
Import settings.....	209
Active import sources.....	209
Passive import sources.....	210
Linked servers.....	210
OpenText Content Manager.....	210
CMIS.....	211
Azure Storage.....	211
Recognition providers.....	212
SharePoint.....	212
Dynamics CRM.....	212
Exchange.....	212
ControlSuite.....	213
OAuth servers.....	213
OAuth Authorization Grant types.....	215
TotalAgility Rest API.....	215
TotalAgility SDK JSON payload.....	216
TotalAgility OAuth clients.....	216

Preface

This guide provides an overview of the Tungsten TotalAgility features.

TotalAgility documentation

Access the full documentation set online, from the [Tungsten TotalAgility Documentation page](#).

You can also access the TotalAgility documentation in offline mode by downloading it from the [Tungsten Automation Fulfillment Site](#) for each language separately.

For a full documentation set, and how to access the documentation in offline mode, refer to the *Tungsten TotalAgility 8.1.0 Release Notes*.

Introduction to TotalAgility

TotalAgility is an Intelligent Automation platform that transforms and simplifies critical business interactions. Use TotalAgility to design, develop, and deploy continually improving business processes that result in better customer engagement, more effective process execution, and increased business agility.

TotalAgility provides multichannel information Capture, business process management and adaptive case management and mobile capabilities in a single, integrated product offering.

TotalAgility supports Business Intelligence (BI) and Analytics, advanced data integration and e-signature capabilities through prebuilt integration to the Tungsten Insight, RPA, Tungsten SignDoc, and Tungsten Communications Manager products respectively.

TotalAgility supports integration with Generative AI providers such as ChatGPT OpenAI, Azure OpenAI and Custom LLM. This integration helps you create workflows along with the associated forms and use them within you solutions.

On-Premise Multi-Tenancy

The On-Premise Multi-Tenant version of TotalAgility, which allows Shared Service Centers (SSCs) and Business Process Outsourcers (BPOs) to offer the software/solutions to their customer base (tenants), includes the following:

- Tenant management system (to create and manage tenants)
- Production environment
- Additional deployment environment

By leveraging the optional On-Premise Multi-Tenant version of TotalAgility, you can deploy a single instance of the software that serves all tenants, such that each tenant has its own set of data that remains isolated from data that belongs to all other tenants.

Tungsten Analytics for TotalAgility

Tungsten Analytics for TotalAgility is an extension of TotalAgility that tracks data as it moves through the workflow to produce Business Intelligence (BI) dashboards. The dashboards help you track data through the workflow; analyze the effectiveness of the processes and resources in real-time; and address business problems.

Data stored within the database displays in standard or custom views that consist of charts, grids, pivot tables, and reports. You can also extract information from the User Tracking tables in your TotalAgility installation and from external databases.

Training

Tungsten Automation offers both on-demand and instructor-led training to help you make the most of your product. To learn more about training courses and schedules, visit the [Tungsten Automation Learning Cloud](#).

Getting help with Tungsten Automation products

The [Tungsten Automation Knowledge Portal](#) repository contains articles that are updated on a regular basis to keep you informed about Tungsten Automation products. We encourage you to use the Knowledge Portal to obtain answers to your product questions.

To access the Tungsten Automation Knowledge Portal, go to <https://knowledge.tungstenautomation.com/>.

 The Tungsten Automation Knowledge Portal is optimized for use with Google Chrome, Mozilla Firefox, or Microsoft Edge.

The Tungsten Automation Knowledge Portal provides:

- Powerful search capabilities to help you quickly locate the information you need.
Type your search terms or phrase into the **Search** box, and then click the search icon.
- Product information, configuration details and documentation, including release news.
To locate articles, go to the Knowledge Portal home page and select the applicable Solution Family for your product, or click the View All Products button.

From the Knowledge Portal home page, you can:

- Access the Tungsten Automation Community (for all customers).
On the Resources menu, click the **Community** link.
- Access the Tungsten Automation Customer Portal (for eligible customers).
Go to the [Support Portal Information](#) page and click **Log in to the Customer Portal**.

- Access the Tungsten Automation Partner Portal (for eligible partners).
Go to the [Support Portal Information](#) page and click **Log in to the Partner Portal**.
- Access Tungsten Automation support commitments, lifecycle policies, electronic fulfillment details, and self-service tools.
Go to the [Support Details](#) page and select the appropriate article.

Chapter 1

Imaging

Using TotalAgility, you can drastically reduce your organization's labor-intensive processes by capturing all types of content for automatic classification, extraction, validation and delivery into applications, processes and repositories.

You can capture information at any point in business process and without human intervention, extract, separate, classify, validate and perfect information. For example, after the loan application process starts, a financial institution may request documents, such as Proof of Income and Credit Reports. The information can be captured anytime from any source, including from mobile or tablet devices, and ingested into the loan approval process.

You can classify documents; define scanner or device settings for reuse; and separate and automatically place documents in folders during capture.

You can export images (or both images and text that has been automatically extracted from the images) to a PDF or other file format, define resolution and quality and more. You can identify text and graphics, convert to HTML and XML file formats, and ensure interpretation by assistive software for the visually impaired.

TotalAgility provides a number of capture nodes that can be used as part of process flow definition. Nodes include Scan, Extraction, Classification and Image Processing. Use of these nodes in a process provides an efficient and effective means to manage the capture of inbound documents and information (see [Capture activities](#)).

These nodes help you:

- Scan a single document or a collection of documents.
- Classify documents into specific folders based on document types.
- Extract and store data from the documents.
- Validate, verify and review documents and folders in a process.
- Process images that are imported and images that are scanned from an MFP.
- Export documents and folders to "System of Records", using an export connector. The System of Records could be a database, IBM/FileNet, EMC/Documentation, SharePoint, and so on.
- Transfer documents or folders between two linked TotalAgility servers

Further, TotalAgility can automatically initiate (or restart or awaken from a wait state) a process to which an inbound document is required. A property, Initialize from Scan, enables this automatic process initiation, for example initiating an instance of the "loan approval" process when a loan application document is received.

Further information on capture features is available in various sections of this Features guide.

Chapter 2

Transformation

Transformation is a technology used to transform data into information. The transformation features act upon raw data and transform it into meaningful information. Transformation of a document includes steps, such as Optical Character Recognition (OCR), Classification, Separation, Extraction, Formatting and Validation.

Tungsten TotalAgility Transformation features include advanced tools and utilities to configure, test and benchmark these steps.

Classification

Tungsten TotalAgility offers classification based on layout, content and rules. Classification is learn-by-example, meaning that sample images are provided to represent individual document types. The software learns to tell classes apart by analyzing these samples. Rules-based classification can be used to augment the learn-by-example classification.

Trainable Document Separation

Trainable Document Separation (TDS) is a classification-based separation technology that examines each page in a document and assigns several classification result options. The page classification results are compared to other surrounding pages and evaluated to determine the most logical way of separating the pages into smaller documents. Like classification, TDS is learn-by-example; all it needs for configuration are sample documents that are correctly separated.

Clustering

The ability to organize documents based on their content is available in Transformation Designer using Clustering. A set of unknown documents is processed, and based on the content or layout, the Clustering feature organizes the documents into groups. Several iterations of clustering are performed, and interaction is required throughout each step of the process. The Clustering feature learns from the changes and improves the clustering results throughout the process. The result of this process is a set of known documents organized in a hierarchy with the relevant class names. This hierarchy can be used by the project for classification and separation training, benchmarking, and testing.

Extraction from unstructured documents

A learn-by-example locator is available to extract data from documents that have no consistent layout. Use the locator to extract data from unique contracts, correspondence, architectural drawings, or even essays and manuscripts. Any type of data can be extracted, such as numeric and non-numeric data, or even an unknown format extraction works best on natural language text.

Extraction from invoices

Several locators, some of which are learn-by-example, can be used to extract from invoices. Header data, line items and amounts are supported. Line item matching using a purchase order database is possible, as well as line item extraction without a Purchase Order (PO) reference.

Extraction from forms

Special locators for forms allow quick setup of zones on multi-page forms. Background (the pre-printed zones and labels) is automatically removed to allow Optical Character Recognition (OCR) or Intelligent Character Recognition (ICR) get the best possible input. Zones are automatically registered to allow for typical shift, stretch and skew on scanned images.

Extraction from tables

Table detection uses a separate recognition engine and machine learning to automatically locate and identify multiple tables on a document. There are three levels of automatic table identification, depending on your requirements and how the Advanced Table Locator is configured and trained.

Extracted table data is available to a downstream system via export.

Extraction – check processing

Parascript technology using the FormXtra recognition engine is supported for extracting data from checks.

Extraction from key-value pairs

The Key-Value Pairs Locator finds values on the document with zero configuration. Users identify the meaning of each value by providing some keywords as "hints." There is no training required, and in many semi-structured documents this locator may be all that you need.

Extraction from the document library

The Predefined Document Type Locator enables you to extract available document types out-of-the-box, without any configure or manual setup with locators, as is necessary for other document types not covered by the Predefined Document Type Locator.

This locator communicates with the cloud-based Tungsten Document Library. This library contains a set of predefined document types that have all the necessary subfields in place so that no additional extraction setup is required.

<<LINK TO DOCUMENT LIBRARY>>

Auto Extract

The Auto Extract Locator uses a Large Language Model to extract data from a document based on the field names or a simple worded description. There is no need for additional configuration, scripts, or training. You can add multiple subfields to a single Auto Extract Locator.

Database extraction

Using a database table in a fuzzy manner is a powerful tool to extract known data, such as the database record representing the vendor sending an invoice, or the customer sending a letter. You can use this easy-to-configure technology to identify document senders.

Extraction - other

Additional locators allow configuration of extraction for almost any need, including highly customized scripting.

Optical Character Recognition (OCR)

Advanced OCR capabilities are offered in Tungsten TotalAgility. OCR serves as basis for classification and extraction. OCR full text can also be stored to allow indexing and searching documents in repositories.

More than 170 languages are supported for OCR.

Recognition engines

Tungsten Transformation comes with the following recognition engines:

Azure AI Document Intelligence

A cloud-based recognition engine that uses Azure AI Document Intelligence. This is available for both page and zone recognition. To use this engine, you require a Microsoft Azure account and an API key for access.

FormXtra

Use this recognition engine for a zone recognition engine to recognize handwritten text in a zone. This profile enables users to extract various field types for a set group of languages. Users can also specify what type of handwriting is expected such as cursive, handprint, or boxed handprint. Some of the field types have specific settings to further refine extraction.

OmniPage

This is the default recognition engine in Tungsten Transformation. This engine provides both page and zone recognition.

Tungsten Clarity

This is a cloud-based recognition engine that is available for both page recognition and zone recognition. A separate license is required to use this recognition engine.

Bar code recognition

Extraction of the following bar codes is also supported:

Linear bar codes (1D)

One-dimensional bar codes contain encoded information, in the form of digits and characters, of a message as bars and spaces. The start and stop markers, the size of the quiet zone required before and after the bar code, and the computation of a checksum can also be part of the code. The following 1D bar code varieties are available for selection:

- Australia Post 4-state Bar code
- Codabar
- Code 11
- Code 128
- Code 32 -
- Code 39
- Code 39 without start/stop character
- Code 93
- EAN-13
- EAN-8
- Extended Code 39
- GS1 DataBar Expanded
- GS1 DataBar Limited
- GS1-128 (aka EAN-128 or UCC 128)
- IATA 2 of 5
- Industrial 2 of 5
- Interleaved 2 of 5
- International Standard Book Number (Bookland)
- Italian Post 25
- ITF-14
- Matrix 2 of 5
- MSI (Modified Plessey)
- Patch Code
- PLANET
- POSTNET
- SCC-14
- SSCC-18
- UPC-A
- UPC-E
- USPS OneCode 4-State Customer Bar code

Matrix bar codes (2D)

Two-dimensional bar codes are similar to linear one-dimensional bar codes but have more data representation capability due to the representation of information arranged in a grid pattern. The following 2D bar code varieties are available for selection:

- Data Matrix
- Data Matrix High Accuracy

- QR Code
- QR Code High Accuracy
- PDF417
- PDF417 High Accuracy

More than 170 languages are supported for OCR.

Natural language processing

The natural language processing engine is available to extract named entities and the mood or sentiment of a document. This engine is installed separately and supports several languages. You can use the Named Entity Locator to extract named entities and the Sentiment Locator to determine the sentiment of a document. You can also use a script alone to further process the extraction results, or a script in conjunction with either the Named Entity Locator or the Sentiment Locator to further process their results.

Named Entity Locator

This locator assigns extracted entities to fields. You can extract the entity name only by using a simple field, or you can use a table field to extract not only the entity name, but also the entity confidence, entity type, and the entity sentiment. Once the entities are extracted, it is necessary to customize a script to interpret the results for your needs.

Custom entities

You can define your own custom entities. This means that when a specific entity is located on a document, the custom entity file is referenced to determine the extracted result. Custom entities support several languages.

Sentiment Locator

This locator extracts text sentiments from a document. This means that the Sentiment Locator is able to determine the overall mood or sentiment of a document based on the words or phrases found on that document. Once the sentiment is extracted, it is necessary to customize a script to interpret the results for your needs.

Summary Locator

This locator uses built-in functionality of the natural language processing engine to extract a summary of a document.

For example, if you are archiving many documents to a database, this locator method can provide a summary of those documents that is saved alongside the document itself. This enables a user to search the summaries or review the summary without reading the entire document, when looking for a specific document.

Themes Locator

This locator uses built-in functionality of the natural language processing engine to extract the theme or topic of a document. This information is then available for custom analysis via script.

Tungsten Search and Matching Server

This standalone 64-bit server uses multiple CPUs to quickly perform a fuzzy search within a database. Use Tungsten Search and Matching Server to extract data from documents or look up data entered by an operator.

Chapter 3

Case and business process modeling

TotalAgility lets you create, view, edit and delete processes, cases, case fragments, business rules, simulations templates and skins. You can also manage supporting artifacts, such as variables, milestones, states and resources, and manage translations. You can import and export processes, work allocation rules and languages.

Business Process Modeling Notation (BPMN)

TotalAgility uses BPMN for process design.

BPMN positions itself as a bridge between process modeling and process implementation. BPMN is readily understandable by both technical developers and business users. It provides a graphical notation that is intuitive to business users yet able to represent complex process semantics.

Start node





A Start node indicates the beginning of a process path.





You can use standard BPMN event types to denote that something happens at the beginning (Start node) of a process.

Event types for a start node

Event types for the start node indicate the circumstances that trigger the start of the process. They are just visual aids; they do not trigger events or perform any functions.

The following table describes the event types available for a Start node and the corresponding BPMN Standard notations.

Event Type	BPMN standard notation	Description
Default		Indicates the default notation.
None		Indicates that no trigger is defined.
Message		Indicates that the receipt of a message, such as a request from a customer, initiates the process.
Timer		Indicates that the process starts at a specific date and time or a recurring time, such as every Monday at 9 AM.

Event Type	BPMN standard notation	Description
Conditional		Indicates that a business condition, such as a balance dropping below a certain value, triggers the process.
Signal		Indicates that an external signal, such as the addition of a new customer, triggers the process.
Multiple		Indicates that any event can start the process.
Parallel Multiple		Indicates that the process has multiple events, and all the events must occur for the process to start.

Activity

An activity is an individual step (service) within a business process, such as getting customer details.

An activity in a process map may have various uses, such as:

- A call to a script that runs automatically or requires feedback from a user, such as a form to be filled.
- A call to a third-party software component to automatically send an email.
- An ordinary activity that facilitates the passing of output and input variables to other parts of the business process.

When you configure an activity with the business rule, create new job, or custom service, and if you double click on the activity, the configured rule, process, or custom service are opened in a new tab.

Annotation

Use annotations to add extra information to a process or activity in a process.

This information is then readily available to the user implementing the TotalAgility site.

Attachment

Use attachments to link additional information to a process or activities within a process.

For example, for a Procurement process, attach process-related documents, such as an exceptions list, terms and conditions, or an example invoice form.

An attachment can be a Word document, Excel spreadsheet, or PowerPoint presentation. Once an attachment is added to a map, it is available to all users who open that map and select to view the attachment.

End node

An End node indicates the end of a process path or the completion of the job.

Use an End node to complete a process or a particular stage of a process that cannot progress any further.

In line with BPMN, an End node can indicate how the job or paths are completing, that is, Escalation, Error, Message, and more.

A process can have multiple end nodes, when of a type that completes the job, all other parallel paths are stopped.

Process paths

Define process paths using decisions and branching rules.

Decision

A decision is a point in a process to select the path the business process must follow. The selected path depends on the evaluation of one or more conditions (decision rules).

By default, a Decision node includes:

- One Condition: Condition on which the rule is evaluated.
- True Path: The path of execution when the decision evaluates to true.
- False Path: The path of execution when the decision evaluates to false.

At runtime, the value of the decision variable is passed as an operand/keyword into the process map and may be evaluated against another variable or value.

For example, in the Loan Approval map, the Send Confirmation Letter and Send Rejection Letter are two possible paths for the Approved decision. If the APPROVED condition evaluates to TRUE, the Send Confirmation Letter activity takes place at which point the confirmation letter is sent to the customer, and the money is transferred to the customer's credit account. Otherwise, the Send Rejection Letter activity takes place, at which point the rejection letter is sent to the customer.

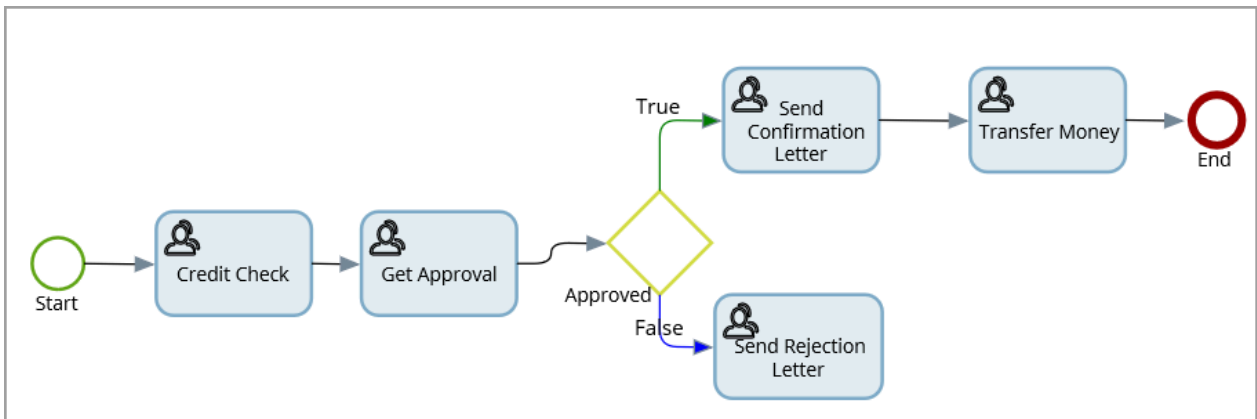

Branching rules

Branching rules help you model complex business logic. They are simple and neater than using numerous decision nodes. Unlike decisions, they are not limited to a maximum of only two mutually exclusive paths.

- Use a decision to model an exclusive choice decision pattern where only one of the two alternative paths is required for the process to continue.
- Use a branching rule to model a multiple-choice decision pattern where the flow is split into two or more alternative paths.

A branching rule must include the following:

- A condition (business rule) for each path (destination node) that must be met before the destination node can become pending or active. The business rule set for destination nodes determines which destination node is activated. Any of the target destination nodes can potentially be activated if each business rule evaluates to True; two or more outcomes can be valid.
- A default node to execute at runtime if none of the conditions is met; this stops the process flow from stalling.

i If you do not specify business rules on the output paths, then all paths are executed normally.

Branching can be either OR (inclusive) or XOR (exclusive):

- **OR branching:** Allows one or more, or all the outgoing paths to be taken. The paths are determined by conditions and if none of the conditions is met, the default path is taken.
- **XOR branching:** Allows only one path to be taken, thus restricting the flow. If multiple true paths exist, the first path is taken based on the alphabetical order of the activity name. If no true paths are determined, the default path is taken. XOR is applicable for all process maps.

Dependents

Dependents are nodes (activities and decisions) on which activity depends for completion.

A node may have multiple paths (parallel paths) flowing from it, resulting in more than one activity becoming pending when the originating node gets completed.

Set dependents if parallel nodes, such as activities must complete before the current activity can become pending. See the following example of the Loan Approval process.

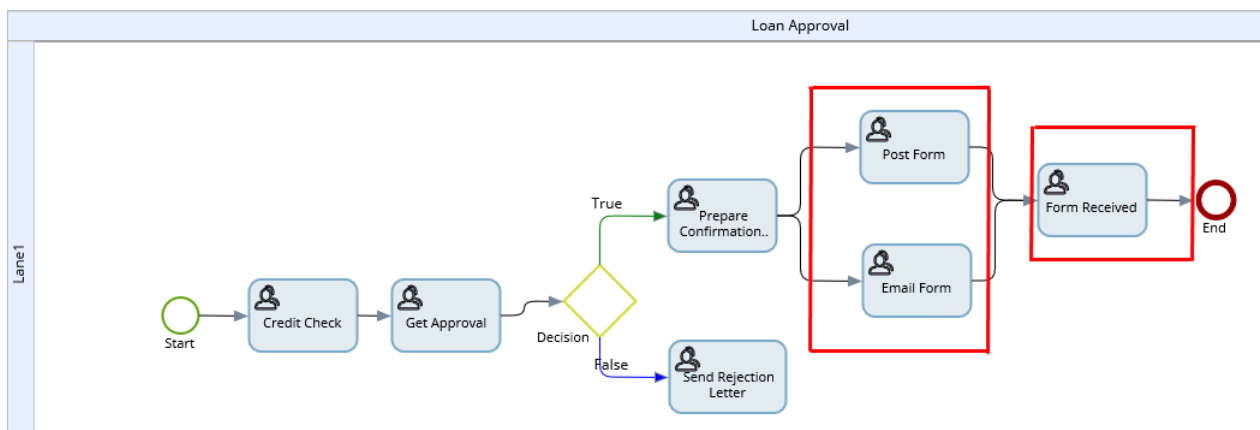

Post Form and Email Form activities are the possible dependents. Forms Received is the activity for which dependents are set.

i You cannot set dependents if there is only one path going into the activity and decision.

Preconditions

A precondition is a rule that must be met before an activity can become pending (manual activities) or progress (automatic activities).

A precondition is the last step to be evaluated before the node becomes pending; dependents and others are determined first. An activity with a precondition is a "waiting" activity.

For example, in the Loan Application process, set a precondition on the Transfer Money activity (for transferring a loan amount into the applicant's account) to allow the activity to become pending only after the Signed_Loan_Agreement event is raised and recorded.

Once the signed agreement is scanned into a third-party Document Management System, this event precondition is met, and the Transfer Money task can become pending. In this scenario, you would use relevant API methods to let TotalAgility know that an external event has been fired.

i When a precondition is set for an activity, the activity goes into an Awaiting Events status. This is like the Pending status except that the activity does not appear on anyone's work queue and no activity notification is sent. Everything else is done based on the activity becoming pending. For example, milestones are updated if set up.

Preconditions can be defined using process events. Preconditions can be satisfied by raising internal or external events. Once the precondition is satisfied, the activity automatically moves on.

Creating preconditions for a process event is slightly more complicated than normal decision conditions because it combines both variables and events (which may have the same name).

A precondition is only available for activities; they are not available for decisions or embedded maps.

During the lifetime of a job, you can reevaluate preconditions to reevaluate any activities that are in an Awaiting Events status. For example, you may reevaluate a precondition when you have manually changed the precondition value after a job has started, and you need all activities in a job reevaluated against the new precondition value.

Loop

Some activities are always available, such as the Contact Customer in a Loan Application process. You can add a loop for such activities. Select the activity and drag from the center of the activity to make a loop. The activity gets looped to itself.

Manage process maps

Use the information in this section to manage maps.

Orientation

You can change the direction of a map layout from vertical to horizontal and vice versa as appropriate for your process or target audience. The process is redrawn accordingly.

Rearrange process

The "Rearrange process" feature automatically redraws your process map in an easy-to-read manner.

Lines

Lines assist with the layout of your process.

Snap to grid

The "Snap to grid" feature automatically aligns an activity to the nearest grid.

Auto placement

The "Auto placement" feature automatically places the activity to the nearest grid horizontally and in accordance with the current activity. Activities added to decisions are placed above or below the decision. When the Auto Placement option is turned off, you can drag the activity to the required location.

Zoom

The pan and zoom functionality can help you navigate process maps effectively. You can easily zoom in and out of large process maps.

Undo/redo

You can undo/redo changes within a process using the Undo ↶ or Redo ↷ buttons on the Action bar. You can undo/redo a maximum of 30 updates, such as typing or design changes. The undo/redo list is cleared when an update is made on any area outside the Design tab.

Variables

A variable is a storage location for values that are retrieved at runtime. Variables are used to store and transport data from one activity to another and are integral to the setup and creation of a business process. Variables are also used to determine paths of execution.

You can create variables at both the server and process levels.

Use process variables to store data for a specific process. Process variables hold values for items that change during the execution of a process. They are local (private) to the map for which they are created. Process (and case) variables can be simple (1 value) or complex (an array of values).

TotalAgility supports many variables such as, Bool, Currency, Date, Float, Long, Checklist, Complex and dynamic complex, String, and others.

Process variable examples

Variable Name	Type	Value
CUSTNAME	String	JuliaR
CUSTADDRESS	String	Hollywood
AMOUNT	Double	100000
Approved	Boolean	True

Initialization variables

The System requires initial information for a process to run. For example, to process a loan application, customer details and the loan amount are required. An initialization variable is any

process variable whose value should be provided when the job is being created. For the Loan application process, you could create process variables such as customer ID, customer name, and loan amount, and then declare the loan amount as the initialization variable.

The order of the initialization variables is configurable within the designer.

Variable types

TotalAgility supports the variables of type Bool, Byte, Currency, Decimal, Double, Float, Long, Short, and Text in a process.

TotalAgility also supports the following type of variables.

Checklist variable

A checklist variable is used to hold checklist information for quality checking and sampling. A single checklist variable can contain several checklist items.

Complex variable

Use a complex variable to hold tabular or array-based data values, such as a list of product details. Two kinds of complex variables are available:

Static complex

Static complex variables are an array (group) of variables of potentially different data types. Static complex variables keep their cell mappings to process variables throughout the job. Every time a mapped variable value is updated in the job, it is reflected in the static complex variable cell.

 A static complex variable can only be created for a process; it cannot be created as a server variable.

Dynamic complex

Data object variable

Use a Data object variable to hold a data model (global or local). This data model then can be used in a process and form.

You can create multiple data object variables referring to the same or different data models.

You can use a data object variable to store the request sent and/or response received from a RESTful service.

Data backbone variable

A Data backbone variable maps directly to a project within a selected Tungsten Communications Manager server and gives access to the data backbone belonging to that project to get or set data in it. Each TCM project consists of one data backbone. The data backbone exposes all the data required to create documents in that project.

A data backbone is an XML structure containing field sets with single fields and nested/repeating data. For example:

```
[Company Details]
Company Name
Address
  Street
  Postcode
  Country
  Code
  Name
[Director Details]
<List of Directors>
  Director Name
  Director Address
    <List of prior addresses>
```

Within TCM, you can add new fields to the data backbone, but cannot delete existing fields. You must refresh the project in TCM integration to view the newly added fields.

You can create multiple variables of this type, each pointing to the same or different projects.

Date and Nullable date variable

Use the Date and Nullable date variable to set the date in a process or business rule.

You can use the @Today macro to get the current date, or a past/future date by adding or subtracting the number of days. For example, to get the date 7 days before the current date, specify the variable value as @Today-7.

When you create a job on a process or use a business rule that is using @Today, at runtime, the value of the variable is displayed as the current date, or current date + (plus) or - (minus) the number of days specified (if any).

When you create a job on a process that has an initialization variable using @Today, the runtime value of the variable is displayed as the current date, or current date + (plus) or - (minus) the number of days specified (if any). The time is set to midnight at runtime. However, you can change the date and time, as required.

Document variable

Use a Document variable where one document type is required, such as submitting proof of address later in the bank application process. Using a Document variable, one instance of a document is added to the repository typically of a known type.

Use Document variables to use document instances in a TotalAgility process or business rule.

Use a document variable as a process initialization variable or as an activity input or output variable. You can also use document fields directly as input or output parameters to an activity.

When you create a job on a process that uses a document variable, the runtime instance ID of the document is stored in the document variable.

Dynamic complex variable

Dynamic complex variables keep their cell mappings to process variables only until they are updated in the job. They are stored against the job and their array size and values can change during the course of the job.

At design time, you can create a complex variable with a maximum of 1000 cells, such as 1000 X 1, 500 X 2, or 5 X 200. However, at runtime, no maximum limit is placed on the number of cells.

The Dynamic complex variable can also be created as a server variable. Both types of variables are created in the same way. However, the Process Initialization option is not available when setting up complex server variables.

Variable members can be either dynamic or static. A static value is one that a user can enter but cannot modify.

Folder variable

Use a Folder variable where multiple document types are required, for example, a bank application where multiple document types are required to process an application. Using a Folder variable more than one document is added to the repository typically of different types. Use Folder variables to use folder instances in a TotalAgility process or business rule.

Use Folder variables to use folder instances in a TotalAgility process or business rule.

When you create a job on a process that uses a folder variable, the runtime instance ID of the folder is stored in the folder variable.

You can use a folder variable as a process initialization variable or activity input or output variable. You can also use folder fields directly as input or output parameters to an activity.

JSON expression variable

Use a JSON expression variable to retrieve required data from the JSON string.

To retrieve data, give any JSON string and retrieve the JSON values as per Expression text(JSON path). For processing JSON, a JSON path is required like to XPath for XML.

You can select a data object variable as your source JSON. You can also retrieve the value of a specific field within a data object variable using expression text as your input and return data type as your output.

JSON path uses special notation to represent nodes and their connections to adjacent nodes in a JSON path. There are two styles of notation, namely dot (\$.name) and bracket (\$['name'] or [name]). The dollar sign (\$) represents the root member object.

String and nullable string variable

A string variable is used to hold text value that is used in a process, form, and across TotalAgility.

You can also define form display properties to specify the type of control that will be used to represent the variable at runtime in a Create new job or activity forms that are either built or generated dynamically.

System variable

These are simple non-editable process variables that give you information, such as who created the job and, the job ID which you typically do not know at design time.

Each System variable holds a value for a specific TotalAgility task. For example, SPP_RES_JOB_Creator holds the User ID of the creator of a job, or the AWF_JOBID holds the ID of the job. This information is only gathered upon job creation.

XML variable

Use an XML variable to use all or part of the XML document.

To use a part of the document, you must create an XML expression to identify the required section of the document.

XML documents can be represented as tree view nodes, and the XML Path Language (XPath) describes a path through the XML document to select elements that match the path.

i The XPath is the expression type of the XML expression variable. For example, to select the first number element of the XML document, the XPath is: `//number` or to select all the book nodes under the bookstore element, the XPath is: `xmlDoc.selectNodes("/bookstore/book")`

- An XML variable created at the server level can be shared between business process maps, where the same XML is used but for different purposes.
- An XML variable created at the process level can only be used with the process map for which it is created, and the XML expression is local to that process map.

XML expression variable

Use an XML expression variable to use all or part of the XML document.

To use a part of the document, you must create an XML expression to identify the required section of the document.

XML documents can be represented as tree view nodes, and the XML Path Language (XPath) describes a path through the XML document to select elements that match the path.

i The XPath is the expression type of the XML expression variable. For example, to select the first number element of the XML document, the XPath is: `//number` or to select all the book nodes under the bookstore element, the XPath is: `xmlDoc.selectNodes("/bookstore/book")`

- An XML expression created at the server level can be shared between business process maps, where the same XML is used but for different purposes.
- An XML expression created at the process level can only be used with the process map for which it is created, and the XML expression is local to that process map.

Activity types

TotalAgility supports both manual and automatic activities.

A manual activity is not capture-related, and it is expected to be performed by a person. Data can be passed to and returned from a manual activity. The resources required to perform the activity can be configured and range from a static resource (administrator) to dynamically driven variables that are populated based on rules.

You can configure C# scripts, VB .NET scripts, Expressions, .NET assemblies, or .NET Form actions, which when run into TotalAgility on a multi-tenant environment, allow or restrict certain actions, such as accessing data from different tenants such as reading memory, file system or database.

For example, if you execute a .NET/C#/VB.NET activity that contains a malicious or any script that tries to access the file system, the activity fails, and the job is suspended. Similarly, if you execute a .NET form action that contains a malicious or any script that tries to access the file system, the action fails and returns an error.

To allow these scenarios to execute, you must first configure the Safe Scripting option in the configuration file. For Safe Scripting configuration, refer to the *Tungsten TotalAgility On-Premise Multi-Tenancy Installation Guide*.

Common activities

Common activities include both manual as well as automatic activities.

Automatic	Manual
Embedded process	Ordinary activity When you add an activity to a process map, it is an Ordinary activity by default. You can change the type of the activity and configure the activity as needed.
.NET	
Web service	
Create new job	
Create subjob	
Data access	
Synchronization	
Loop	
Expression	
Business rule	
Email	
Generative AI activity	

Automatic	Manual
<p data-bbox="232 338 345 365">Condition</p> <div data-bbox="250 380 656 474" style="background-color: #e0f2f7; padding: 5px;"> <p data-bbox="258 394 634 464">i This activity is only available when configuring a decision tree.</p> </div>	

Ordinary activity

An ordinary activity is a manual activity that facilitates the passing of output and input variables to other parts of the business process.

Embedded process activity

Embedded process activity permits you to add a process within another process by adding activities and attributes (variables, roles, states, milestones) to the parent map.

Use embedded processes to create a logical group of activities and if you need to add attributes to a running job rather than perform a discreet operation in the case of a subjob.

An embedded process activity is useful in scenarios, such as:

- Initial process map is too large.
- A process may be reused in other maps.
- A process may be reused by another department or company.

You can embed smaller process maps into the main map (parent map). The standard processing rules for an embedded process map are like other process maps.

The activities in an embedded process may need to use or modify variable values in the parent. If you embed a process map you must declare the same variable names in the embedded process (child) as the parent. All variables created in the parent or child map are visible to the entire job.

.Net activity

A .Net activity permits you to configure a call to a .Net assembly to perform some custom operation typically used for integration, data manipulation, and so on. TotalAgility interrogates the assembly to show the available classes exposed by the assembly.

On the selection of the class, the methods and their parameter lists are displayed. You can map data to and from the .Net call back into variables defined within the process.

.Net assemblies can be added independently of the maps and held either as a reference to a location on disk or placed within the TotalAgility store.

Web service activity

A Web service activity permits you to configure a call to a web service (SOAP or SOAP WCF).

A web service is typically used for integration, data manipulation, and the rest, performed by services that reside on a remote server.

Web services come along with a Web Service Definition Language (WSDL). The WSDL describes all the metadata of a web service, such as methods and parameters. TotalAgility uses the WSDL to generate a client proxy that allows you to select classes and methods in the Web service activity.

TotalAgility interrogates the service and shows the available classes exposed by the service. On the selection of the class, the methods and their parameter lists are displayed. You can map data to and from the service call back into variables defined within the process.

Web services can be added independently of the process maps in which they are consumed.

To use a Web service activity, you must first set up a web service reference.

Business rule activity

Use a Business rule activity to invoke a business rule defined within TotalAgility.

A business rule permits users to simplify complex logic into reusable rules, access to which is provided by this node. When the map is released, any changes to the rule are automatically applied to the process.

Create subjob activity

A subjob is an entirely self-contained process, which can be invoked by the parent process.

A Subjob activity is typically used when processes have been decomposed for reusability and readability purposes. For example, in a Banking process, the main purpose of a Credit Check subjob is to complete a credit check and return a customer's credit rating. The main process is unaffected by the implementation of the subjob if the credit rating result is relayed back to the main process so a bank clerk can continue to process the loan application. The Credit Check subjob could potentially be reused in a few key business processes, such as loan applications, credit card applications, and mortgage loans.

 This activity is not supported in a business rule.

The difference between a Subjob and Create new job activities is that the path in the parent launching the job waits until the subjob returns, thus permitting data to not only be passed to the subjob but also returned from it.

The difference between a Subjob activity and an embedded process is that none of the variables, milestones, and the rest of the subjob are added to or inherited from the parent.

Data access activity

Use a Data access (DAS) activity to permit the process to interact with a database.

You can access tables, views, and stored procedures, construct queries within the Designer, and map data from the process onto the query. You can also get, add, update, or delete database records from the process.

A DAS activity is typically used for direct integration with a third-party database without the need to write any code.

Synchronization activity

Use the automatic Synchronization activity to converge and diverge multiple paths of the process, permitting the designer to control the logic of the process.

If merging paths must complete before the synchronization activity can complete, then [dependents](#) should be configured.

Expression activity

Expression activity permits you to perform operations on data.

These can be single arithmetic operations, such as add, multiply, subtract, or string manipulation such as Trim, Uppercase, and Date functions such as add months, or get today's date.

An expression node reduces the amount of custom .NET code or scripting needed by providing the most used functions used for data manipulation. You can validate and test the expression.

Create new job activity

The automatic Create new job activity creates a new job that can run independently of the job that created it.

You can create a job, of type case, job, or associated job and map data from the existing job into the new job. A Create new job activity is typically used to span a job that will run parallel to the parent job (cross-selling opportunity) with potentially no inter-job communication (although it can be achieved if desired).

For example, in a Homeowner Insurance process, after you capture all customer details, through the main Homeowner Insurance process, you can add a Create new job activity into the main process to spawn a separate process called Selling Car Insurance. Although you will pass customer details into the Create new job activity, it is an independent process.

 You must ensure that any required initialization parameters are added to the map that is used to create a new job.

Loop activity

Use a Loop activity to automatically control the extraction of data from an array.

This activity lets you take a row at a time from the array and pass it through your process before looping back to get the next row. For example, to send an email to a list of resources, you would perform a database query to return the list. To process each resource, use the loop node to iterate through each resource on the list or until the end of the data.

Email activity

Use an Email activity to permit the process to send an email. The email activity can send emails to the recipients from worker resources within TotalAgility or to external resources.

To send emails to external email addresses, you must have relay permission on the SMTP server. Otherwise, you can only send emails to the email addresses listed on the SMTP server.

i By default, the relay permission is not enabled for security reasons. Sometimes the SMTP server, SMTP service, or Exchange server are also referred to as Relay servers, as they can relay the mail messages to another mail server.

Before you configure the Email activity, you must configure one of the following:

- Email server.
- SPP_SMTP_SERVER variable

By default, a server variable, SPP_SMTP_SERVER with a value of "localhost", is available in TotalAgility. Change this value, depending on the SMTP server you are using. The value of this server variable can be an SMTP server name or IP address.

i Once you change the value of the SPP_SMTP_SERVER, restart the TotalAgility Core Worker services for the changes to take effect.

You can also specify the port number on which communications with the SMTP server must take place. By default, the port number used by the email node is 30, which you may change as needed. For example, if your port number to send emails is 60, change the server variable to localhost: 60.

i If a value is provided in the SPP_SMTP_SERVER variable and no email server settings are defined within the System (System > System settings > System > Email server (SMTP)), then the SMTP server name available in the variable is used when sending an email. If the email system settings are defined, then those details take preference.

You can configure the subject, attachments, and the rest, and dynamically create the body of the email.

i In the Email activity, the plain text is being replaced by a variable with the same name. For example, if you have a variable called ID and if you type the text VOID, the plain text will be replaced by VO[ID]. However, this only happens at design time; at runtime, the values validate and appear correctly.

Generative AI activity

Use the Generative AI activity to pass a request to the AI provider within your process (all process types, flow rules, and decision tree). For example, enter a piece of text, select an image or file using the Attachment icon, or provide the document text and request a response from the AI provider.

Condition activity

Use a Condition activity to define branching rules in a business rule decision tree.

i This activity is only available when configuring a decision tree.

Capture activities

The Capture activities include both manual as well as automatic activities.

Automatic	Manual
Classification activity	Scan
Extraction	Document review
Delete	Validation
Composite	Verification
Export	
PDF generation	
Document conversion	
Bar code and patch code detection	
Image processing	
Image quality analysis	
Transfer	
Mark finished	
OCR	

i If a capture activity is used in an embedded process, it inherits its capture settings such as classification group Capture access permissions and other miscellaneous capture process settings from the parent process. However, if the capture activity is in a subjob, it gets the settings from the subjob process and not the parent process.

Classification activity

Use the automatic Classification activity to classify documents into specific folders based on document types.

You can use this activity in a process to create a record at runtime in the Job History or View Job in TotalAgility. Classification activities include a separation profile property.

This activity is automatically executed at runtime if the Transformation Server is installed on your system. Refer to the *Tungsten TotalAgility Installation Guide*.

If the process fails at runtime, the job is suspended, and the job note is updated with a message describing the reason for suspension.

Extraction activity

Use the automatic Extraction activity to extract and store data from the documents.

This activity is automatically executed at runtime if the Transformation Server is installed on your system. Refer to the *Tungsten TotalAgility Installation Guide*.

If the process fails when you run this activity, the job is suspended, and the job note is updated with a message describing the reason for suspension.

Validation activity

Use the manual Validation activity to validate documents and folders within a process.

This activity type is not supported in a business rule.

Document review activity

Use the Document review activity to manually review the documents and folders in a process.

This activity type is not supported in a business rule.

Delete activity

Use the Delete activity to automatically delete a document or a folder at runtime.

Using this activity, you can mark the deleted documents as complete and define whether to suspend a job if the deletion fails.

 This activity is automatically executed at runtime if the Transformation Server is installed in your system. Refer to the *Tungsten TotalAgility Installation Guide*.

Composite activity

Use the automatic Composite activity to perform one or more capture actions as a single activity in a process.

Using the Composite activity instead of corresponding standalone activities improves the performance of a process in the Transformation Server.

 Use standalone activities only in a non-linear process map, or if you need other activities inside a chain of the composed steps.

Export activity

Use the Export activity to automatically export documents and folders to "System of Records", using an export connector.

The System of records could be a database, IBM/FileNet, EMC/Documentation, SharePoint, and so on. You can configure this activity to mark the exported documents as complete.

You need to set up an export connector to export the document types associated with the process map. At runtime, when the export activity is executed, the documents in the process map are exported to the back-end system.



- TotalAgility in an Azure environment does not support the Export activity.
- You must associate one or more export connectors with the process and document types. Refer to the *Tungsten TotalAgility Export Connector Help*.
- The Export activity is not supported in a subjob.

PDF generation activity

Use the PDF generation activity to automatically create a PDF from a document or all documents in a folder.

A PDF generation activity creates a PDF from a document using the settings defined in a PDF generation profile. This is called the generated PDF file. In addition, the activity allows you to configure how certain metadata fields in the generated PDF are populated either from a document field or from a fixed value defined in the configuration of the PDF generation activity. If you chose "Document", the PDF metadata field is populated with the value of a document field. This works only if the document is classified. If the document is not classified, no metadata fields are written, and only a PDF with no metadata field is created.



This activity is automatically executed at runtime if the Transformation Server is installed on your system. Refer to the *Tungsten TotalAgility Installation Guide*.

Document conversion activity

Use the Document conversion activity to apply all the document conversion/normalization parameters configured in the [document conversion profiles](#) to any document independent of the source of import. The document conversion is supported in synchronous and asynchronous maps.

If you use Microsoft Office applications for document conversion in the Document Converter, the conversion process can only run on one system at a time and the conversions of documents cannot be done in parallel.

You can use the Document conversion activity to do the following:

- Use the Document conversion activity for document conversion and the Image processing activity for eVRS image processing.
- Normalize images. You can then create pages for the images.
- Address issues such as scaling and orientation and then use any Capture activities in your process map.
- Convert documents (MSG, EML, MS Office documents, CSV, TXT, LOG, RTF, XPS, OpenOffice, HTML, MIME HTML (MHT), VCF) to PDF.



This activity does not support converting image files (GIF, JPEG, PNG, HEIF, HEIC, BMP, JFIF) to PDF. In such cases, use the PDF generation activity.

- Convert password-protected PDF documents to PDF, TIFF, or PDF/A.

 This activity does not support converting password-protected PDF Portfolio and ZIP files.

- Convert images (GIF, JPEG, PNG, HEIF, HEIC, BMP, JFIF) to TIFF.

Bar code and patch code detection activity

Use a bar code and patch code detection profile activity to access the detected bar codes and patch codes within the process.

When retrieving the bar code structure, instead of the names of bar code types, their numeric identifier values are displayed.

Image processing activity

Use the automatic Image processing activity to process images that are imported and images that are scanned from an MFP.

If a process has an Image processing activity, it is applied to all documents that the job gets created for, irrespective of the method selected for creating the job (MFP, Web scan, Scan create new job, Upload, Import, Mobile, and the rest). For example, if you scan 10 documents or upload them or import them upon job creation, all of them are processed by an Image processing activity if there is one in the job's process.

To process images that are scanned from an MFP, you must add the Image processing activity to the map. If this activity is the first activity in a process that is started by a Device create new job form, you must set the precondition for this activity to `[SCANNED] > 0`.

The Image processing activity uses Transformation Server to convert documents and images into TIFF images and apply image enhancement filters. The following formats can be converted:

- BMP
- GIF
- HTML
- JPG
- Microsoft Word in .docx (Word 2007 or later) and .doc (earlier to Word 2007) format
- Microsoft Excel in .xlsx and .xls format (versions Excel 97 through Excel 2010)
- PDF
- PNG
- RTF
- TXT



- We recommend that you use the Image processing activity to process PDF documents so that a TIFF representation is available for actions such as OCR lassoing. For more information, refer to "PDF handling" section in *TotalAgility Best Practices Guide*.
- To convert an image file to TIFF, use the Document conversion activity and then use any other Capture activities in your process map. For example, to convert PNG to TIFF, use the Document conversion activity for conversion, and then use the Image processing activity to improve the TIFF using the EVRS settings or image enhancement settings.

The Image processing activity uses "EVRS settings" or "Image enhancement settings" and parameters, such as Paper size, Resolution, and Color mode in the Scan/VRS profile for normalization. The activity has two tasks: converting documents of all formats to TIFF and normalizing all TIFFs so that the resulting document is tiff and has the desired size, resolution, and color depth.

Advanced EVRS settings take preference over the image enhancement settings. For example, if you select Auto rotate in the Image enhancement settings section but add an Advanced EVRS settings string that does not enable Auto rotate, the Auto rotate setting is disabled because the presence of the string causes EVRS to ignore the image enhancement setting.



The Delete blank page setting is an exception. The EVRS string can only enable Blank page detection, but if you need to delete a blank page, you must select the Delete blank page setting.

Multipage documents and TIFF files are split into separate files for each page.

Document files (Word, Excel, HTML, RTF, and TXT) are identified automatically according to their MIME type. If the MIME type is not set or cannot be recognized, the file is treated as an unknown format. If the process fails at runtime, the job is suspended, and the job note is updated with a message describing the reason for suspension.

The Image processing activity creates a record in Job history or View job in the TotalAgility Workspace at runtime. Where applicable, the text from the source file is saved as OCR data. Multipage documents are stored as document objects, and image files are stored at the page level. The original files are stored with the document source.

You can increase the Image processing logging by modifying Kofax.CEBPM.ProcessingService.Host.exe.config available at the following location:

```
Tungsten\TotalAgility\Transformation Server
```

```
The default log level is: <add name="TraceLevelSwitch" value="Warning"/>
```

To enable full image processing logging, replace 'Warning' with 'All', This may be useful for troubleshooting.

Image quality analysis activity

Use the Image quality analysis activity to analyze the quality of an image without the need to process or update the page image.

This activity determines if the image has any issues such as glare, shadow, focus, and blur that may impact extraction results. Once the analysis is complete, the information can be used later in your business process.

i The image quality analysis is only supported on a page level image. To analyze the quality of source level documents such as PDFs, you must convert the documents to individual TIFF images.

TotalAgility only supports image quality analysis for use with images of small documents such as ID cards or passports, taken with a phone camera device. It does not support image quality analysis for images of larger documents or non-mobile images.

Scan activity

Use the Scan activity to scan a single document or a collection of documents.

If multiple scan activities in a process referred to the same document or folder variable, the original version of the extraction group is reused. The version remains the same throughout the lifetime of the job, even if the extraction group is changed after the job is created. This activity type is not supported in a business rule.

Verification Activity

Use the manual Verification activity to verify the documents and folders in a process.

This activity type is not supported in a business rule.

Transfer activity

Use the Transfer activity to transfer documents or folders between two linked TotalAgility servers.

Creating a job on a process and executing the Transfer activity results in the following:

- Moves the document or folder and associated metadata from the current server to the target server and places them at the root of the target server.
- Deletes the document or folder and associated metadata from the source server.
- Transfers all documents and subfolders to the target server if moving a folder.
- Does not decrement the volume count on the target server.
- Does not create the Extraction or Classification groups on the target server. You must import them manually.

When executing the Transfer activity, the transfer fails if:

- The link to the target server was removed.
- The user credentials supplied for the target server are incorrect.
- The folder or document is locked by another user on the current server.

If a job fails, restarting the job ignores all items that were moved before the job failed. It will only move the items that were not previously moved.

When importing or exporting a process that uses a Transfer activity, the name of the link between the servers is also exported or imported. If a link with the same name exists on the target server, the Transfer activity uses that link. Otherwise, the target server displays the message "Unknown" in the activity configuration, and the job is suspended.

Mark finished activity

Use the Mark finished activity to mark a document as finished, with a corresponding time stamp.

You can use a folder or document as input. If a folder is used, all the documents (including documents in sub-folders) in the folder are marked as finished, with a timestamp. This activity also marks the document as complete for reporting purposes.

OCR activity

Use the OCR activity to perform OCR on documents in a process map. OCR is performed on all ingested documents including the PDFs. Even if the PDF has text information, OCR is performed. At runtime, the Transformation Server executes this activity like other automatic Capture activities using the "Transformation" volume licenses for every page.

Tungsten activities

The Tungsten activities include the following automatic activities.

- [RPA](#)
- [SignDoc](#)
- [TCM compose](#)
- [TCM distribute](#)
- [TCM pack](#)
- [ControlSuite](#)

RPA activity

Use an RPA (Robotic Process Automation) activity to choose a robot to be invoked by selecting an appropriate robot from projects within the RPA Server.

Select the appropriate robot and map variables to its inputs and outputs. The RPA robots are used for integration into third-party products.

SignDoc activity

Use the SignDoc activity to define a signing package to get the documents digitally signed.

To define a signing package, you need the SignDoc server to use, the documents to be signed or reviewed and the recipients and their email addresses to sign or review the documents. Additionally, you can specify a name for the signing package.

When a SignDoc server is added to TotalAgility, all the available templates within the selected SignDoc server become available for defining a signing package. When you define a signing

package, you can either create a new template or use the existing template from SignDoc. A template consists of documents and signers required for digital signature. Once the signing package is created, SignDoc sends an email to the signer address specified in the configuration along with the link to the documents to be signed. For the signing ceremony, TotalAgility uses the generic names specified for the signer or reviewer during template creation. You can customize the generic names to display names so that the documents are sent with the display name. For example, configure Consultant for Doctor or manager's actual name for Manager. Once the signing ceremony is complete, SignDoc sends a notification to TotalAgility to complete the SignDoc activity.

TCM compose activity

Use the TCM compose activity to automatically generate and distribute communication documents to the user as part of the process flow.

These documents are based on the templates defined in the Tungsten Communications Manager (TCM). The template type can be a document template or a set of templates available within the document pack. You can add additional documents to a document pack if the document pack contains Import slots (as defined in the TCM). These documents become part of the pack and can be reviewed or distributed along with the rest of the contents of the document pack.

The TCM compose activity allows you to compose and distribute documents.

The supported distribution mechanisms are print, email, portal, SignDoc, or output management.

Output management allows you to distribute each document pack based on the centralized rules that can be configured in the TCM Rules engine. These rules can be due to legal requirements, corporate policies, or customer preference.

For example, if you are sending an insurance policy to Netherlands, and according to the legal requirement the policy needs to be delivered to the customer, then the Portal could be a possible delivery channel for any document pack that contains a policy, and those would have to be delivered through e-mail or print.

 As the TCM Rules engine is available in TCM 5.1.1, we recommend that you use TCM 5.1.1 if you wish to distribute documents using output management in TotalAgility.

TCM distribute activity

Use a TCM distribute activity to distribute documents through print, email, portal, SignDoc, or output management later from when the documents were created in TCM.

When distributing the documents using SignDoc, you do not pass in details of the signers as part of the configuration; instead, the signature lines are defined in the TCM template using fields from the backbone. At runtime, the data held in that field (in the backbone) determines the name and email address of the person who needs to perform the signing ceremony.

The output management mechanism allows you to distribute each document pack based on the centralized rules that can be configured in the TCM Rules engine. These rules can be due to legal requirements, corporate policies, or customer preference.

For example, if you are sending an insurance policy to Netherlands, and according to the legal requirement the policy needs to be delivered to the customer, then the Portal could be a possible

delivery channel for any document pack that contains a policy, and those would have to be delivered through e-mail or print.

TCM pack activity

Use a TCM Pack activity to extract documents from a TCM pack.

ControlSuite activity

Use a ControlSuite activity to send documents and document metadata to the ControlSuite server and initiate a new workflow.

Microsoft activities

The Microsoft activities provide the ability to integrate with key Microsoft products, such as SharePoint, Dynamics CRM, and Exchange.

The Microsoft activities include the following automatic activities:

- [SharePoint create site](#)
- [SharePoint create folder](#)
- [SharePoint add Item](#)
- [SharePoint delete Item](#)
- [SharePoint uploader](#)
- [SharePoint move Item](#)
- [SharePoint get document](#)
- [Dynamics CRM](#)
- [Exchange server get attachments](#)
- [Azure blob storage import](#)
- [Azure blob storage export](#)



- Dynamics CRM and Exchange server get attachments activity types are not supported in On-premise multi-tenant and Azure environments.
- Only SharePoint add item and SharePoint uploader activity types are supported directly in an Azure or TotalAgility On-premise multi-tenant environment. All other SharePoint activities on these environments can be configured using an Integration server installed locally.

SharePoint create site activity

Use the automatic SharePoint Create site activity to create a new site in a SharePoint integration site.

You can define the look and feel of the site using the default SharePoint templates, or the custom templates provided by TotalAgility. The custom templates provided by TotalAgility include a team calendar, contacts list, document folders, job list, work queue, and announcements for a document-centric Case site.

In a Case map, if you apply the Tungsten case template for the new SharePoint site, you can access the shared calendar and address book directly from TotalAgility.

While creating a new site, you can allow the default navigation to appear on the site page. The permissions specified for the parent site are automatically applied to the new site.

SharePoint create folder activity

Use the automatic SharePoint create folder activity to create a new folder in a SharePoint integration site.

You can provide a static value or use a TotalAgility variable to specify the folder location and name.

Configure TotalAgility to retrieve the folder identifier from SharePoint and add the identifier to a variable. When the job finishes, use the information from the variable to identify and select the folder you need.

SharePoint add item activity

Use the SharePoint add item activity to automatically add a document to a SharePoint library, to subfolders in a SharePoint library, or to the root of a SharePoint list.

Lists in SharePoint include communication lists, tracking lists, and custom lists. You can add documents to local and online SharePoint sites as needed.

If a document is checked out, use this activity to check in the document to SharePoint. You can also declare that a document is a record, which adds the document to the record center.

 The options of checking in a document, declaring a document to be a record, and overwriting documents are only available for a local SharePoint site and not for an online SharePoint site.

Configure TotalAgility to retrieve the item identifier from SharePoint and add the identifier to a variable. When the job finishes, use the information from the variable to identify and select the item you need.

The SharePoint add Item activity differs from a SharePoint uploader activity as described in the table.

SharePoint add item	SharePoint uploader
Uploads a document to any of the following SharePoint locations: <ul style="list-style-type: none"> • Root of a list. • Any library in SharePoint. • Any subfolders available in a SharePoint library; uploads a document only to a document library in SharePoint. 	Uploads a document only to a document library in SharePoint.
Supports item metadata.	Does not support item metadata.

SharePoint delete item activity

Use the automatic SharePoint delete item activity to delete an item or folder from a SharePoint library, SharePoint library subfolder, or the root of a SharePoint list.

The SharePoint lists include communications lists, tracking lists, and custom lists.

If multiple items with the same name exist, all matching items are deleted. Except for the Survey and Discussion Board, you can delete all other items.

SharePoint uploader activity

Use the automatic SharePoint uploader activity to upload a document to a document library in SharePoint. You can upload documents to both local and online SharePoint sites.

Provide a static value or a TotalAgility variable to specify the TotalAgility Web Service and target document URL, and the file path for the source document. You can also specify the content type of the uploaded document. This helps you organize, search, and retrieve all documents of a particular content type at runtime.

SharePoint move item activity

Use the SharePoint move item activity to move an item from one location on a SharePoint site to another on the same site.

You can also update the metadata of a moved document, and declare the document to be a record, which adds the document to the Record Center.

SharePoint get document activity

Use the automatic SharePoint get document activity to copy or check out a document from a SharePoint site to your local computer.

Dynamics CRM activity

Use the Dynamics CRM activity to create a new entity instance, retrieve the required information from an entity instance, and update and delete an entity instance for a CRM business unit directly from TotalAgility.

You can assign valid GUID values for CRM lookup and numeric values for picklist fields in a Dynamics CRM activity.

You can assign a Dynamic Complex variable to support retrieval/assignment of values for Party list fields in the Dynamics CRM activity.

For example, an entity instance called Person consists of Name as a string field and Nationality as a picklist field with the following values.

Name	Jack
Nationality	1: Irish 2: American

When you create an entity instance by passing `Name, 1`, and retrieve the entity instance details from Dynamics CRM, the following information is retrieved: `Jack, Irish`.

i The Dynamics CRM activity is only available for TotalAgility on-premise; it not available for Designer running in On-premise multi-tenant and Azure environments.

Exchange server get attachments activity

Use the Exchange server get attachments activity to automatically retrieve all the files attached to your email and route them to a specific destination. This activity allows you to track and maintain all attachments in one location.

Azure blob storage import activity

Use the Azure blob storage import activity to automatically import blobs from a storage container into a folder.

Azure blob storage export activity

Use the Azure Blob Storage export activity to automatically export files from a folder in TotalAgility to a container in Azure blob storage.

CMIS activities

The CMIS activities are used to interact with a CMIS-compliant EDMS. This means that this standard integration can be used without having to write specific adapters.

See [CMIS](#) for more information.

This group includes the following activities:

- [CMIS get document](#)
- [CMIS add document](#)
- [CMIS update document](#)
- [CMIS create folder](#)
- [CMIS check in document](#)
- [CMIS cancel checkout document](#)
- [CMIS find document](#)

CMIS get document activity

Use the automatic CMIS get document activity to copy or check out a document from a CMIS-compliant site.

Specify a document using the document name or unique identifier.

CMIS add document activity

Use the CMIS add document activity to add a document to the repository of a CMIS-compliant site.

Add documents to the library, subfolders in a library, or the root of a list. You can also specify the metadata for a newly uploaded document.

CMIS update document activity

Use the automatic CMIS update document activity to update the properties of a document.

CMIS create folder activity

Use the automatic CMIS create folder activity to create folders in a repository on a CMIS-compliant site.

CMIS check in document activity

Use the automatic CMIS Check in a Document Activity to check-in documents to a repository on a CMIS site.

You can also update the properties of a checked-in document if required.

 The option to specify the file location in CMIS check in document node is not available for the Designer running in on-premise multi-tenant and Azure environments.

CMIS cancel checkout document activity

Use the automatic CMIS cancel checkout document activity to undo modifications to a document that was checked out of a CMIS-compliant site.

Undoing a checkout discards the changes and restores the document to the state it was in before being checked out.

CMIS find document activity

Use the automatic CMIS find document activity to search for documents in a repository using the document metadata as the search criteria.

When the job is executed, the activity returns all the documents matching the search criteria.

 The CMIS find document activity only works if the Discovery service is configured on the CMIS-compliant site.

OpenText activities

OpenText activities provide the ability to integrate with the OpenText Content Management system.

This group includes the following activities:

- [Content Manager create folder](#)

- [Content Manager add document](#)
- [Content Manager get document](#)

 The OpenText activities are only available for TotalAgility on-premise; they are not available for Designer running in on-premise multi-tenant and Azure environments.

Content Manager create folder activity

Use the Content Manager Create folder activity to create a folder in a selected Content Management system.

Use the defined default value for the location, a location relative to the default, or another location. Once you create a folder, use it to manage documents within the folder.

Content Manager add document activity

Use the OpenText Content Manager Add document activity to add a new document or check in a checked-out document to a selected Content Management system.

The Add document activity returns Document URI, a unique identifier that you can use to get or check out the documents later.

If the Content Management system has multiple folders and documents with the same name, use a unique record number or a variable containing the Uniform Resource Identifier (URI) to ensure that you select the folder and document that you need.

 The Content Manager Add document activity is not available in Azure and on-premise multi-tenant environments.

Content Manager get document activity

Use the Content Manager Get document activity to download or check out a document from a Content Management system on your computer.

If the Content Manager system contains multiple folders and documents with the same name, specify the unique Record number or select a variable containing the Uniform Resource Identifier (URI) to access the folder or document you need.

 The ID is the unique record number of a folder or document in the Content Manager system. A Folder or Document URI is the unique value of a folder or a document and is captured using a TotalAgility process variable.

Script activities

The Script activities are used whenever the expression, .Net, and Web services are not appropriate.

They remain in the product for legacy reasons. We hope that the newer features of the product will help to reduce the need for any custom code. Until then provide the mechanisms to write code within the process.

This group includes the following automatic activities:

- [Script](#)
- [C#](#)
- [VB .Net](#)

For a script to work in your process, assign process variables as input and output to the script activities.

- To retrieve (get) the value of a process variable for use within a script, add the variable as input to the activity.
- To change (set) the value of a process variable within a script, add the variable as output to the activity.

i When configuring a script, you can manually enter variables, such as ([Firstname]) or select a variable by right-clicking on the rule editor, such as S1 (Process variable). Selecting the variable is only a shortcut to inserting the variable ID without the need of manually typing it. For the script to be valid, you must insert quotes around the variable. For example, ["Firstname"] or ["S1 (Process variable)"].

You can copy and paste script in script activities in Designer to/from a text editor such as Visual Studio. When pasting from a text editor into a script activity, any existing variable IDs in double quotes found in the script text are automatically recognized as variables in the script/rule.

Script activity

A script is a series of instructions that can be executed consecutively in a given language.

Use the automatic Script activity to perform certain actions, such as:

- Generating email content
- Sending an email
- Looking up data in a database
- Creating a letter in a word processor
- Looping a sequence of activities in a process
- Saving user details to a text file



- TotalAgility does not support Script activity type in an Azure environment and the on-premise multi-tenancy environment.
- On importing a previous version of a process map which contains a script activity, the activity appears read only. The execution of the activity succeeds only when the activity is defined in the Integration server and the "Run on Integration server" property is selected.

C# activity

Use the C# Script activities to write .Net scripts.

The TotalAgility Designer allows you to create two types of .Net Script activities: C# and VB.Net.

When configuring a script, right-click on the rule editor and select the process and server variables to add to the script.

TotalAgility can validate and run a script without requiring the script developer to build and deploy .Net assemblies. The .Net compliance of TotalAgility reduces development time and increases the ease of deployment.



- The C# script activity is compiled compilation at design time. It needs the full path to any referenced DLL, as it is being used as a reference for .NET compiler.
- At runtime, the C# script activity uses .NET loading rules to find the referenced assembly once the C# script assembly is compiled; it does not use the file path.

When the compiled C# script assembly executes and looks for referenced DLLs, it checks the GAC first and then current directory such as .NET framework 64 folder.

You must either use full path such as C:\lib\helper.dll or place the DLL into the .NET framework 64 folder.

Example of C# script

In this sample C# script, firstname and surname are input variables. The value of these variables is used to construct the value of the fullname variable, which is an output variable.

```
using System;
using Agility.Server.Scripting.ScriptAssembly;
namespace MyNamespace
{
    public class Class1
    {
        public Class1()
        {
        }
        [StartMethodAttribute()]
        public void Method1(ScriptParameters sp)
        {
            string firstname = {string}sp.InputVariables["FirstName (Process variable)"].ToString();
            string surname = {string}sp.InputVariables["surname (Process variable)"].ToString();
            sp.OutputVariables["fullname"] = firstName + " " + surname ;
        }
    }
}
```



The script only works if firstname and surname are set as input variables, and fullname is set as an output variable.

VB.Net activity

Use the VB.Net Script activities to write .Net scripts.

When configuring a script, you can manually enter variables such as ([Firstname]) or right-click on the rule editor and select process and server variables to add to the script. When you select a server

variable, the variable appears as Variable name [Server variable]. For the script to be valid, you must insert quotes around the variable. Example: "[Firstname]".

TotalAgility can validate and run a script without requiring the script developer to build and deploy .Net assemblies. The .Net compliance of TotalAgility reduces development time and increases the ease of deployment.

Example: VB .Net script

In this sample VB .Net script, the values of FirstName and LastName input variables are used to construct the value of the Fullname variable, which is an output variable.

```
Imports System Imports Agility.Server.Scripting.ScriptAssembly
Namespace MyNamespace
Public Class Class1
  <StartMethodAttribute()> Public Sub Method1(ByVal sp As ScriptParameters)
  '
  ' TODO: Add start method code here
  '
  Dim FirstName
  Dim LastName
  FirstName = sp.InputVariables("FirstName")
  LastName = sp.InputVariables("LastName")
  sp.OutputVariables("Fullname") = FirstName + LastName
End Sub
End Class
End Namespace
```

 The script only works if FirstName and LastName are set as input variables, and Fullname is set as an output variable.

Other activities

Other automatic activities available in TotalAgility include XML, Resource info, Document creation, and more.

- [XML](#)
- [Resource info](#)
- [Job owner](#)
- [Job variable](#)
- [Sleep](#)
- [Supporting info](#)
- [RESTful service](#)
- [Document creation](#)
- [Ready for review](#)
- [Complex variable](#)
- [Data list](#)
- [Design](#)
- [Add document to document set](#)

RESTful service activity

Use the RESTful service activity to integrate TotalAgility with external applications.

The RESTful service activity can integrate with external applications through the RESTful web service references.



- TotalAgility supports only simple types of RESTful web services, which should not be used with complex data structures.
- TotalAgility supports specifying custom headers to be passed to a RESTful service activity.

RESTful web services typically map the four main HTTP methods to the operations they perform: Post, Get, Put and Delete.

The web service only sends the basic HTTP verbs – GET, PUT, POST, and DELETE – to the server and expects JSON or XML as the response.

For example, `http://service.com/emp/123`

XML format:

```
<Emp>
  <Name>ABC</Name>
  <Id>321</Id>
  <Email>abc@domain.com</Email>
  <Org>Tungsten</Org>
</Emp>
```

JSON format:

```
{
  "Name": "ABC",
  "Id": "321",
  "Email": "abc@doamin.com",
  "Org": "Tungsten"
}
```

Sleep activity

A Sleep activity is used to delay a job for a specific period.

At runtime, the sleep activity makes the job wait for the specified amount of time. For example, in an event map, which is triggered when a .NET call fails to send an email, you can configure the Sleep activity to set the job to sleep for 60 seconds before attempting to send the email again.

Job owner activity

Use the Job owner activity to set the current owner of the running job. Based on some rules or decisions, the owner of the job may vary.

The job owner owns the jobs regardless of who performs or completes the tasks. This always ensures the visibility of assigned jobs. For example, as the team leader (TL) is responsible for all jobs

the team completes, assigning the TL as the owner of the jobs means that the TL can view and track the progress of the team as required.

 A Job owner activity is not supported in synchronous maps.

A job owner can:

- Be an individual or a group resource. However, only one resource can be the job owner at a time.
- Be a static or dynamic resource. If dynamic, the real job owner can be assigned at runtime.
- Change the owner of the job at runtime; however, a supervisor can also do so.

Job variable activity

Use the Job variable activity to extract information from a running job and return the values into variables defined within the current job. It is commonly used in exception maps which are reused across multiple jobs.

For example, in a Housing Benefit Claims system, you can launch a Job Overrun exception process map if it takes more than two hours to process a particular Housing Benefit application form. The Job Overrun exception map would extract data, such as who is processing the claim and other details from the Claim Housing Benefit job.

The Job variable activity reduces development time, which would otherwise involve the following steps:

- Calling the `getjobvariablevalues` API.
- Setting up a complex variable to pass data into `getjobvariablevalues`.
- Extracting and passing values from the complex variable into the process variables for subsequent processing.

XML activity

Use the XML activity to construct or modify an XML document without using third-party components.

Using an XML activity, you can:

- Add, modify, or delete an attribute in an XML document, or add a new XML string to the document.
- Avoid typing lengthy code and element name conflicts by defining namespace bindings.
- Validate the XML by using the XSD schema.

Resource info activity

Use the Resource info activity to extract information, such as name, email address, or supervisor ID, about a specific resource rather than use the `.NET` method on the SDK.

The resource information is obtained by specifying the resource identifier. The resource identifier can be a resource ID, resource or role name, or an email address.

Supporting info activity

Use the Supporting info activity to generate contextual information that may help a user track job progress.

For example, in the process of handling insurance claims, use a Supporting info activity to provide information containing the customer's name, insurance type, and claim amount to the user.

You can:

- Add multiple Supporting info nodes to a process to allow updating the contextual information as the job progresses.
- Use the APIs to update and display the supporting info.
 - Update the supporting information directly by calling `JobService.UpdateJobCustomerData`.
 - Display the supporting information for a job to the user by calling any of the TakeActivity APIs.
 - Display the supporting information on the work queue of the user by calling the `GetWorkQueue` API.

Document creation activity

Use the automatic Document creation activity to create different document types, such as a Microsoft Word document or an HTML file (web page), in a process map.

For a document, you can specify the template to use and the placeholders to populate.

 Only Microsoft Word templates (.dotx) can be used to create a new document.

In Microsoft Word, fields are used as placeholders for data that might change in a document and for creating form letters and labels in mail merge documents. Merge fields let you customize the content of individual documents.

For example, to create a letter, you may define a letter template with the following placeholders:

- <Date>
- <Recipient's Address> (may include addressee's name, street address or post office box, city, province, postal/zip code, or country)
- <Salutation>
- <Subject>
- <Body>
- <Complimentary Close>
- <Signature Block>

The Document creation activity also considers carriage returns passed into a document and adjusts the other text accordingly. For example, <<Address>> could be multiline.

Within TotalAgility, you can generate a document that contains a table where a row is populated for each line item passed to it. This helps control the formatting of the data passed into the placeholders and creates documents in which tables are automatically populated with dynamic data.

Use placeholders to populate a table in a document with dynamic data. Position each placeholder in the row and column where you want to populate the data. For example, to populate the Loan Application table from Row 2 Column 1, position the placeholder there. See the table.

Loan ID	Loan Amount	Loan Duration	Applicant	Address	Contact Number
«Details»					

The placeholder placed in the table shall populate the table with the data in the mapped variable.

Once the table is populated, any text outside the table shifts accordingly.

Loan ID	Loan Amount	Loan Duration	Applicant	Address	Contact Number
101	15000	5 years	Mark	Derry	7412545612
102	30000	10 Years	Peter	Hyderabad	6455456542
103	50000	12 Years	Srinivas	London	9878455612
104	2000	1 Year	Charles	Belfast	7418529631
105	1000000	20 Years	Reddy	Derry	7456123891

The placeholder placed in the table shall populate the table with the data in the mapped variable.

i During design, you might not know the number of rows (records) required in a table. To address the issue, add rows dynamically by passing the input data through dynamic complex variables to a table.

You can create an HTML page based on a Word template and save the output to a variable, for use across the Designer.

For example, you can map the output variable to the body of an Email node, so that whenever a new HTML page is created based on the selected template, an email is sent to the relevant users.

Ready for review activity

Use the Ready for review activity to set the checklist state as ready for review. At runtime, the current state of the checklist is displayed in read-only mode and the next column is displayed in an editable mode.

For example, in a document review process:

1. Resource A completes a checklist as part of the "Write" activity.

2. The state of the checklist is set to "Ready for review" by a "Ready for review" node.
3. The checklist is available as part of the "Review" activity, which in turn can be completed by Resource B.
4. The checklist is displayed in two columns (as the state is "Ready for review"): the first column displays the original values (as set in the Write activity) and is read-only; the second column is editable.

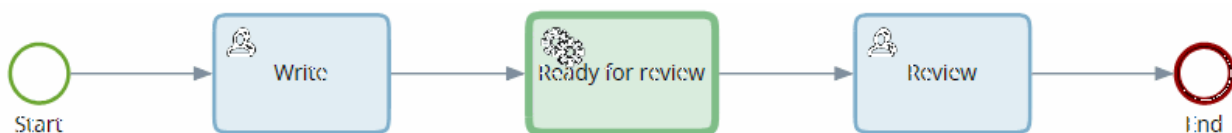

Complex variable activity

A complex variable activity allows you to manipulate the contents of a complex variable.

You can add, delete, get rows, and update cell values.

i Only dynamic complex variables are supported for the Complex variable activity.

Data list activity

A data list activity allows you to manipulate the repeating data within a data object.

You can add, delete, and get rows, and update the cell values.

Design activity

Use the Design activity to view and implement any design changes requested from a TotalAgility Apps user.

Add document to document set activity

Use the Add document to document set activity to add mandatory documents within the process that are dependent on certain conditions (document rules) to the document set at runtime.

Custom service activity

The Custom service activity is an automatic activity that can be used in a business process, case definition custom service, and business rule.

Activity input and output

Define input and output variables for an activity.

You can add the same variable as both input and output. However, you cannot add the same variable more than once as input and output. When using an entity variable to an activity as input or output, either set an entire entity or an individual attribute as input or output variable.

You can use both process and server variables as input (NOT output) to Classification, Extraction and Composite activities for use in the Transformation Designer (KTD) script. However, you can only use simple variable types and cannot use Document, Folder, Checklist, XML, XML Expression and Complex variables. Therefore any document or folder variables configured for these activities are not available for use as input variables. The String input variable for Scan profile name on Composite activity is also not available for use.

Input variables for capture activities become available in Transformation Designer script. For example, if you consume an input variable called "test", you can access this variable in the Transformation Designer script as:

```
pXDoc.Fields(1).Text =  
pXDoc.ParentFolder.XValues.ItemByName("KTA.InputVariable.test").Value
```

Service level agreement

Service level agreement (SLA) is the visual representation of a threshold status of activity state on a work queue.

You can specify fully configurable SLA indicators for an activity allowing process participants to rapidly see when an activity is at risk of exceeding the target and allowing them to take corrective action if necessary.

TotalAgility supports a maximum of five statuses, which are defined at the server level. The status titles, such as Red, Amber, or Green are configurable.

Example: Define the SLA status indicator for an activity to change status

Configure the SLA thresholds of a process whose expected duration = 2 Hours.

- Amber threshold = 1 hour (Before)
- Red threshold = 30 minutes (After)

If the activity starts at 12:00:00 AM and the expected finish time is 2:00:00 PM:

- Up to 1:00:00 PM, the SLA status indicator appears Green on the work queue. This means that the activity is pending, and the current time is outside the Amber threshold.
- When the time is 1:00:01 PM (less than 1 hour from the expected finish time), the SLA status indicator turns Amber. This means that the activity is still pending and due to be completed; the current time is within the defined Amber threshold.
- When the time is 2:30:01 PM (30 minutes after the expected finish time), the SLA status indicator turns Red. This means that the activity is overdue. If the current time is within the defined Red threshold or exceeds the expected duration, the SLA status of the job remains Red.

Time and cost

You can configure deadlines, service level agreements, triggers and cost properties for a process and an activity.

Time and cost for a process

Duration/Expected finish time

The time when the job is expected to complete. The duration can be static (in days, hours and minutes), dynamic (a date variable) or a milestone.

Service level agreement

See [Service level agreement](#).

Expected cost

Overall expected cost of performing the job.

Budget

The amount of money allocated to a process (mainly case fragments). A budget helps managers track and monitor key business processes to determine whether the process is under or over budget.

The budget can be a static amount or dynamic amount.

The budget and expected cost are different. For example, a typical Appeals case process is made up of several case fragments such as Register an Appeal, Medical Examination, or Convene Court Hearing. A budget is usually associated with the overall case fragments and is the summation of the expected cost of each case fragment.

Duration/Budget Triggers

See [Process triggers](#).

Time and cost for an activity

Priority

The level of importance for the activity with 1 being the highest priority and 100 being the lowest. Setting the priority ensures highest priority activities are picked up first. Activities are processed sorted by due date and then by priority.

Target duration

The expected duration required to complete the activity. The target duration helps to gauge productivity. For example, if the expected duration of an activity is 5 minutes, the user must spend not more than 5 minutes on the activity. A user who spends 10 minutes instead of 5 has a 50% productivity rating. The target duration can be static (in days, hours, minutes and/or seconds) or dynamic (a Short or Long variable).

Target due date

The due date when the activity is expected to be complete. The target due date can be calculated based on target duration, variable or a milestone.

- **Target Duration:** The due date is calculated as the target duration from the time the activity becomes available. If a lead time is used, then activity due date = target duration + lead time. For example, if the target duration of an activity is 4 hours, its lead time is set to 2 hours and the activity becomes available at 12:00, the due date of the activity is 18:00 (depending on business calendar). If the user takes an activity at 13:30 and completes it by 17:30, the activity is not overdue. However, if the user takes the activity at 16:00 and completes it at 20:00, the activity is overdue by 2 hours.
- **Variable:** The activity due date is calculated as the value given for the due date. If you specify the lead time, the activity due date is calculated as variable +/- lead time. If the business calendar is enabled, due dates are calculated based on working days and hours. For example, one working day is equal to 8 hours rather than 24 hours.
- **Milestone:** The due date is calculated based on the selected milestone. If you specify the lead time, the activity due date is calculated as milestone +/- lead time.

Lead time

The time period when the user may take the activity. For example, if set to 2 days, the user can take the activity any time during the 2 days.

The lead time can be negative (Before) or positive (After). For example, if the value of Goods Delivered milestone = 17-02-2012 17:00, the target duration of Final Check activity = x variable, and Lead Time = -1 hour. This means that the Final Check activity must be completed 1 hour before the Goods Delivered milestone is reached.

OR

If the value of Goods Delivered milestone = 17-02-2012 17:00, the target duration of Goods Received activity = x variable, and Lead Time = 1 day. This means that the Goods Received activity must be completed 1 day after the Goods Delivered milestone is reached.

 The negative lead time cannot be set if the target duration is used to calculate the activity due date.

Service level agreement

See [Service level agreement](#).

Triggers

See [Activity triggers](#).

Expected cost

The overall expected cost of the activity upon completion.

Fixed cost

The cost of the activity irrespective of the length (duration).

Milestones

A milestone signifies the completion of a major activity or a set of related activities.

Use milestones to mark major events, such as important dates or deadlines in a business process. For example, use a milestone to mark a product delivery date.

Recording of a milestone target date starts once the job starts. The milestone's target date automatically changes if you reschedule the associated activity. For example, in an Employee Hiring business process, if the Employee Start Date and 3-Month Review Date are two milestones and if the employee's start date changes, the 3-month review date also changes.

After defining milestones at the process level:

- Add milestones for a map or activity to track job progress. Set interim milestones to track if you are behind schedule for the interim target date and take corrective action while you still have time to recover. For example, add a milestone for the entire Deliver Training Course process or set interim milestones for the Basic and Advanced courses.
- Use milestones to schedule a process or activities and calculate the due dates. For example, schedule the Security Check task to appear on the HR Manager's work list four weeks after the Employee Hire Date milestone date.
- Schedule activities forward or backward from a milestone. For example, schedule the Set New Employee Machine task to appear on the Network Services work list two days before (- 2 days) the Employee Start Date milestone date.
- Set the milestone to achieve when an activity becomes pending or is completed. For example, set the Candidate Selection Complete milestone to achieve as soon as the HR Manager takes and completes the Select Final Candidate Based on Interview Results task.
- Reschedule or change a milestone target due date. The system automatically updates the activities (that are not pending) with due dates linked to that milestone. For example, if you shift the Interviews Completed milestone date, the due dates of linked activities, such as Shortlist Candidates and Book Interview Room, shift automatically.
- Set milestones relative to each other when one milestone depends on another milestone. For example, make the Training Materials Completed milestone date relative to the Deliver Training Course milestone date. If you reschedule the Training Course, all linked milestone dates are rescheduled automatically.
- Link milestones to process states. For example, the Hiring process includes a series of states from Pre-interview > Interview > Selection > Hired.

 State refers to the status of a job at a particular point in time. A percentage complete is usually assigned to each state so that you can monitor the progress of a job. For example, a parcel can go through a series of states from New (0 %) > Dispatched (70%)> Confirmed (100%).

You can set a milestone to be static, dynamic, or relative to other milestones:

- A static milestone has a target duration in days, hours, minutes, and seconds, or relative to when a job is created. For example, set the "Interviews Complete" milestone to reach 24 days after the "Hiring" job starts.
- A dynamic milestone has the target duration as a date variable that contains the duration value.

! You can use the Tungsten TotalAgility Workspace to change the milestone dates at runtime. If you change a milestone variable value, the milestone is NOT updated automatically; you must use the UpdateJobMilestone API to update the milestone.

- When you set the target duration relative to another milestone, at runtime, and if you update a milestone, all milestones relative to it are also updated. For example, if the "Deliver Training Course" milestone is relative to the "Training Materials Completed" milestone, and if you change the "Training Materials Completed" date, the "Deliver Training Course" milestone is rescheduled automatically.

You can set the milestone to reach after (for example, three days later than) or before (for example, three days earlier than) the due date of the selected milestone. If the value is 0, the milestone will be achieved when the relative milestone is achieved.

Once a milestone is associated with a process or activity, you can view associations for a milestone.

States

States are the changes through which a process can pass from inception to completion. Use states to monitor the status or percentage complete of a particular job. For example, a parcel order can go through a series of definable states, such as ORDER CONFIRMED > PACKED > DISPATCHED > IN TRANSIT > DELIVERED.

You can associate actions with the state and associate the state with an activity. The actions are initiated when the activity becomes pending and the state of the job changes. Or when the state of the job changes at any time during the lifetime of the job. For example, you can change the state when viewing job properties or by using an API on the SDK.

You can associate a state with one or all the following actions:

- [Restart](#)
- [Event](#)
- [New Job](#)

Restart action

Use the Restart action to bypass certain activities and restart the job at a different point in the process when the job reaches a specific state.

For example, in an Employee Onboarding process, define the following states of a job:

- New Employee (0%)
- Security Clearance Approved (50%)
- Employee Onboarding Complete (100%)

If the new employee is not given security clearance, the job would roll back or restart at the initial point in the process.

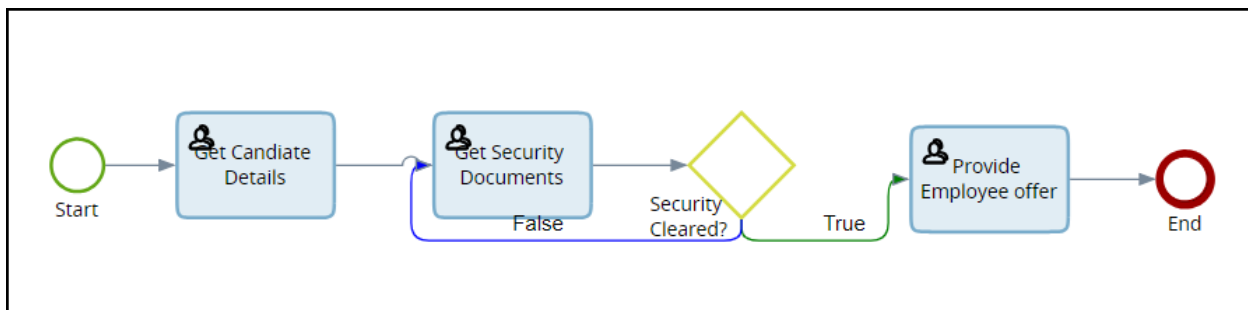

You can also restart a job at an activity within an embedded process when a job state changes.

i Use the ChangeJobState API to apply the Restart action.

Event action

Use the Event action to associate a business event with a state such that the event action takes place when the state of the job changes and the activity completes.

For example, to have up-to-date real-time reporting, define business events, such as New Customer Accounts, Approved Mortgage Loans in a Banking process, and then use states to record approved mortgage loans.

Use the State event identifier when raising events. The State event identifier identifies and records the state event.

To monitor and extract the information from specific fields of an event, map the event parameters to process variables.

New Job action

Use the New Job action to associate a process with a state. Set the state so that when the state of the job changes, the system spawns the process to perform a certain action. The associated process is completely independent of the main process. The new jobs can be run automatically, depending on requirements.

For example, in a Goods Delivery process, when the state of a parcel order changes from IN TRANSIT to DELIVERED, the system can launch an independent process called Send Customer Invoice.

Process events

With TotalAgility, you can model both external and internal (inter-process) synchronization points.

TotalAgility monitors specific business events and responds by completing an activity that has been in a "wait state" for that business event.

You can record when real events raised against a job have occurred, which subsequently determines when a task that is in a wait state can continue or be completed.

TotalAgility can handle both types of events:

- **External:** Events that occur outside of TotalAgility and apply 80% of the time. For example, processing the car insurance application can continue once the loan agreement is signed.

 Use the TotalAgility API methods to record external events.

- **Internal (inter-process):** Events that occur between different process maps within TotalAgility.

Notes

Use notes to insert comments related to your process. For example, you can use a note to suggest a process improvement.

A process note can only be added in the Tungsten TotalAgility Workspace (see *Tungsten TotalAgility Workspace Help*). However, once added, you can view the note in the TotalAgility Designer, and indicate whether an action has been taken for the note. The note details display the date and name of the person who took action.



- Process notes are created and updated independent of process versions.
- Notes cannot be added or deleted within a process map.

Data models

You can define a Data model local to a process, rule, or custom service.

A local data model is useful for one-off integrations when you do not have to reuse the data model. However, if you intend to reuse the data model later, you can promote it to a global model.

You can also create a local data model using a sample JSON file. On adding a JSON file, the JSON format is parsed, and a tree structure is created. The field names in the data model match that of the JSON, and the field types are implied from the JSON sample. Any ambiguous field types are set to string. You can edit the data model by changing field types or deleting the fields that you do not want. You can create a data model for simple JSON strings, with strings having nested objects multiple objects, and with an array of data,

Document set

A document set is a group of related documents that can be managed either individually or as a single entity. You can configure a document set in your process, case definition, and case fragment.

Using a document set, you can add documents and define document rules to the document set and determine whether the document set is valid. For example, you cannot send the application for approval until all document requirements have been met.

A document set rule gives complete visibility to the status of the documents required to complete a process. For example, a document set rule can be used to halt the process at a stage until documents 1 of type A and 2 of type B are received.

When the document set is turned on, you can use the document set properties (read-only) when configuring a decision, activity, and exit condition. You can make use of the Valid (Bool) and Comment (String) and Count properties of the document set within the variable selector. If a document set within a case definition is turned on, you can access the document set properties in a decision for the case fragment (Case document set). For example, you can use the Valid property in a decision or use the Comment property as an input to a manual activity that is requesting more documents from the customer.

 A document set is not supported in a synchronous process. You cannot use a document set enabled process/case as an embedded process or subjob.

On upgrading TotalAgility from 7.9.0 or importing a process that makes use of the document set (from TotalAgility 7.9.0):

- A message displays stating the process contains unsupported nodes and you are not allowed to save/release the process until the unsupported nodes are removed.
- When you execute a process containing these nodes, it will fail.
- Document set fields used within the document type rules and activities do not work at design time and runtime.

Roles

Many organizations assign work to a role, such as a Project Manager, rather than directly to a named individual.

Using roles rather than naming individuals gives you more flexibility in that you may not know the name of the person who will perform a task, although you may know the role required.

In TotalAgility, you can assign work to one of the following:

- An individual, such as John Smith.
- A role, such as Finance Manager.
- An organizational group, such as Finance.
- An unknown resource, where you use a variable, and the system identifies the resource at runtime.

- Someone previously involved in the process, such as the job creator or the person who performed a previous activity.

When designing a process, you can define roles that are specific to that business process.

You cannot use groups or other roles as role members. But an individual can belong to more than one role. Changing the members allocated to a role in one business process does not affect any other business processes in the system even if they have the same role name.

A role can be fixed or floating. See [Types of roles](#).

Once a role is created, assign a role to an activity.

If the activity is an embedded process, it uses the role from the parent map (if the role already exists).

If the activity is a subjob, it uses the role created for the subjob and not from the parent map.

Types of roles

A [role](#) can be fixed or floating. Any changes to fixed (static) roles affect all existing and new jobs, whereas the changes to floating roles affect only new jobs.

Fixed roles

Fixed roles are roles where role members are not likely to change in the immediate future. For example, a company usually has only one Finance Director; an organization may have five Executive Engineering Supervisors.

Use fixed roles:

- When the number of members for the roles is not likely to change. A fixed role can have multiple members but cannot have a group or another role as a member.
- When a task within a process needs to be performed by a known set of role members (case workers) who are not likely to change, and you know who they are.

During design, any changes made to a fixed role impact all new and existing jobs created from any version of that process.

For example, in the following illustration, Jake joins the Engineering Supervisor fixed role. He will immediately see all activities assigned to this role in all live jobs for the Approve Site Design process.

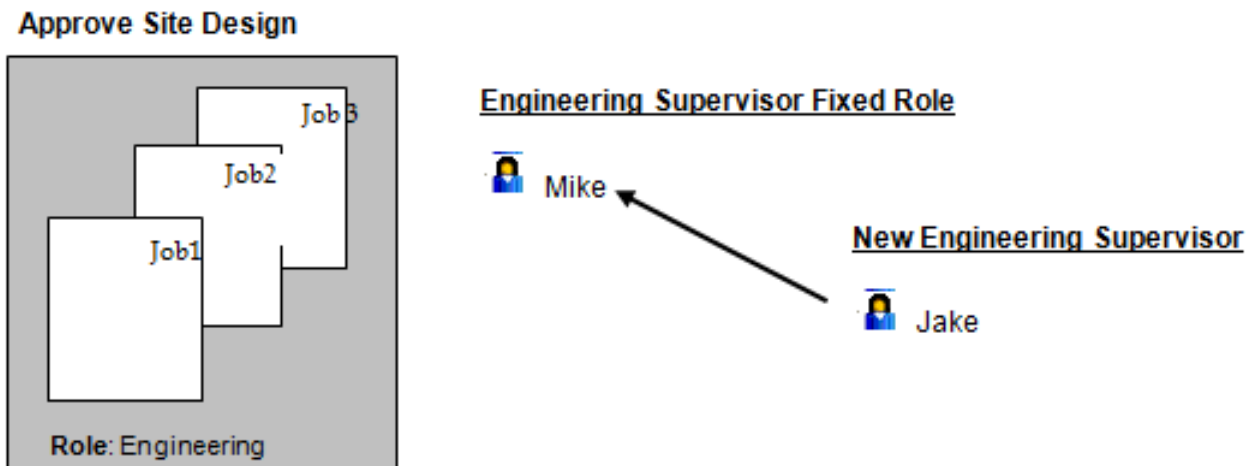

Floating roles

Floating roles are the roles where the role members are added or updated depending on the task or job.

Floating roles are job-specific and allocated on a per-job basis at runtime. For example, a new legal case may need to be assigned to a specific type of case worker. A drug case or a homicide case would require case workers who specialize in these fields. The case worker assigned depends on the actual job instance. You could use a web page to let a user populate the case worker role member dynamically at runtime or change role members at any time.

Use a floating role when the changes to the role members impact only a specific job that is based on a specific process.

Roles defined at the case level are automatically available to any fragments associated with the case. A change at the case level filters through to all activities in related fragments. In addition, you can also define a role at the case fragment level.

Resource assignment

Assign resources and roles to an activity and configure email notifications.

You can assign resources manually, or by applying rules.

Static versus dynamic resources

Resources can be static, or dynamic based on whether the resources are assigned to an activity at design time or runtime.

Static resources

Assign resources at design time if you know in advance which group, individual, or role can perform the job. For example, to hire personnel, select HR.

i A process map has access to all roles created within that process map. For a fragment, any roles defined at a case level are also available. You can assign roles to an activity along with other types of resources, such as groups, individuals, or variables.

Dynamic resources

Assign resources at runtime to make the decision at the time of taking the activity. For example, select a resource with a specific skill level to complete a complex job.

Manual allocation versus dynamic allocation

You can assign resources and roles to an activity either manually or dynamically.

Manually allocate resources

Manually define which resources should work on a particular activity. Allocating resources manually gives you the flexibility to assign more efficient resources to activities of high importance to better balance the work.

i You can manually allocate resources only for manual activities. Manual allocation and rules cannot be used simultaneously.

When the activity is set to use manual allocation, the status appears as Awaiting Allocation. However, if preconditions are defined for an activity, the status is Awaiting Events, and once the necessary events are raised, the status changes to Awaiting Allocation.

Once a resource is assigned to the activity awaiting allocation, the status of the activity changes to Pending.

Dynamically allocate resources

You can allocate resources at runtime, depending on their skills and availability. Allocating resources dynamically has the following advantages:

- Provides more flexibility to your business processes, as opposed to using design-time static resources. Static resource allocation only works in the ideal working environment where each activity is assigned to a specific person who is always available.
- Helps you model real-life work allocation. In real life, jobs can only be assigned to the right user (with the right skills) who are available at a given time.

To define a dynamic resource, do the following:

Define a String variable for the process and assign this variable as a resource to the activity. At runtime, the System populates this variable with a value containing the Resource ID in the XML format.

 You can use a .NET activity to make the method call and populate the string variable. This activity is normally inserted before the dynamic activity.

TotalAgility provides APIs to use as dynamic variables. For example, DynamicResourceService is used to create dynamic resource XML. Several methods are available within DynamicResourceService, such as AddResource, AddGenericResource, DeleteResource, GetNumberOfResources, and AddResourcesUsingServerIds. One method is used to pass in a resource username and get back the resource ID in XML format.

The method to use depends on the conditions within the process map.

You can assign resources dynamically with or without applying rules or using a previous resource.

Assign resources by applying rules

Apply rules if resource requirements for an activity are complex.

For example, apply rules if more than one resource is required to review and approve a document. By applying rules, you can group the reviews as a single activity with multiple resources, rather than separate activities with different resources.

You can also apply rules to an entire business process, and not just a single activity. You can assign rules to a Create Subjob activity; a subjob is created for each resource assigned to this activity.

 You cannot apply rules if resources are assigned manually.

Activity access

You can specify if single or multiple users should work on the activity and the order in which they must complete the activity.

Exclude resources

If the required variable is not available, you can create a new variable directly from the activity properties panel. See *Create a process variable while configuring activity properties*.



- You can exclude a resource or role from completing an activity. For example, you can assign the Expenses Approval activity to everyone in the Finance group, except for the person (job creator) who submitted the expenses claim.
- You cannot exclude a resource if it is directly assigned as usable resource.

Use exit condition

Use exit conditions to ensure that people do not work on activities that are already rejected. You can set up an exit condition for an activity so that the activity is complete when either the exit condition is met or all the resource settings are complete. For example, if two resources must approve a loan but either one can reject it, the resource settings require both resources to complete the activity. But the exit condition is set so that the activity can be completed if either resource rejects the loan.

Communicate with resources

You can communicate with resources by setting up email notification, sending resource notes or creating alerts.

Activity notification

An activity notification is a way of notifying a resource through email that work is ready in an activity and is pending in the queue. When a job is created on the process, an email is sent to the usable resources of the activity for which activity notification had been enabled.

You can set an activity notification for a process as well as an activity. When set for a process, any manual activities added thereafter inherit the settings. When set for an activity, the settings apply only for that activity.

You can create the content of the email, such as subject and body, and embed a URL in the email to take the user directly to the work. For example, set an activity notification on the Validate Loan Form activity that alerts a Banking officer to check the details on a loan application. A URL embedded within the email launches the relevant web page or job with the customer's details, so the officer can approve or reject the loan application.

 An activity notification only works if the SYSTEM Process Email Activity process map is installed. See [System processes](#).

Resource notes

Resource notes allow you to send a note directly to another resource.

A full API set is available to read notes sent to you by other resources, create new notes and delete read notes.

This feature is available in the Resource Mailbox in TotalAgility Workspace. When you log onto the TotalAgility Workspace, you can view all messages in your inbox and reply or send new messages to other resources.

You can effectively communicate within the TotalAgility Workspace itself, without using any Mail servers. For example, use this feature to direct a resource to take up a priority case. You can then quickly post a note to the relevant user from within the TotalAgility Workspace. You can also view any unread notes.

A Pending notes icon appears on the header of your TotalAgility Workspace to indicate pending unread notes.

Alerts

An alert appears on the work queue of the resource to notify them of any impending escalations. You can create an alert for a milestone, process or an activity.

Triggers

Triggers are user-defined conditions that can automatically initiate a response and help you avoid violations and better manage your business processes.

For example, set up a budget trigger to execute when 90% of the budget for a process has been used and to inform you in advance if a business process is about to go over budget.

Trigger types

TotalAgility includes the following types of triggers:

- [Budget triggers](#): To avoid cost violations.
- [Duration triggers](#): To avoid target duration breach in a process.
- [Activity triggers](#): To avoid target duration breach in an activity.
- [Milestone triggers](#): To avoid deadline violations.

Trigger creation

Use an escalation map to create a specific job to deal with job duration, budget, activity due date, or milestone triggers.

 To track the source of the trigger, you must assign variables as initialization parameters to the escalation map.

Alternatively, create an alert task to appear on the work queue to notify a resource of any impending escalations.

You can associate multiple triggers for a job or an activity. For example, in the Personnel Hiring process, set two triggers in the Schedule Interview milestone:

- Trigger 1 to execute 2 days before the target milestone date so you can ensure all pre-interview tasks are completed.
- Trigger 2 to execute 2 days after the target deadline has passed, to remind you to send out offer or rejection letters.

Process triggers

Create a process trigger to actively manage your Service Level Agreements.

The process triggers include:

- [Duration triggers](#)
- [Budget triggers](#)

Duration triggers

Set a duration trigger for a process to execute when the set period in relation to the expected job due date has passed. The duration triggers help to monitor the progress of a business process and ensure timely escalations.

Triggers are only executed for an active job; they are not executed if the job is on hold or completed. See the following table for an example.

Job due date	Job escalation date	Job status	Current date	Trigger fired? Yes/No
12.00.00 26.06.2013	12.00.00 26.06.2013	Job Alive	12.00.00 26.06.2013	Yes
12.00.00 26.06.2013	12.00.00 26.06.2013	Job Complete	12.00.00 26.06.2013	No
12.00.00 26.06.2013	06.00.00 27.06.2013	Job Alive	06.00.00 27.06.2013	Yes

Budget triggers

The budgeting or costing shows how resources relate to processes. It helps management benchmark and focus on becoming more competitive and cost-effective over time.

The budget triggers help you monitor and deal with a business process that is about to go over budget. You can configure budget triggers to act when the budget spent runs outside its normal business tolerance and when the expected cost of a completed job is under or over the estimated target budget.

The budget triggers are typically used for business processes that use resource costing; the budget spent is calculated based on resource costs, fixed costs, and actual time spent on tasks.

Example: To illustrate when a trigger is executed for the specified tolerance, budget, and job cost

See the following table for examples of whether the trigger will be executed for the specified tolerance, budget, and job cost. Column description is as follows:

- **Budget:** The budget set at design time.
- **Cost so far:** The accumulated cost of a job created on a map with tolerance and budget.
- **Target budget tolerance(%):** The specified tolerance in percentage of the budget when the trigger will be fired.
- **Is trigger fired?:** Whether the trigger is fired. The reason why the trigger was fired or not fired.

Budget	Cost so far	Target budget tolerance (%)	Is trigger fired?
£300	>=30	10%	Yes. The trigger is executed as soon as the cost is recorded as £30 against that job.
£500	>=450	90%	Yes. The trigger is executed as the cost against the job reached £450, that is, 90% of £500.
£300	140	50%	No. A trigger is not yet executed because the cost so far is only £140, and has not reached the £150 mark (50% of £300).
£1000	1090	110%	No. A trigger is not yet executed because the cost has not yet reached £1100 (110% of 1000).
£100	>=120	120%	Yes. The trigger is executed as the cost has reached £120 (120% of 100).

Milestone triggers

Use milestone triggers to take an action close to a target date. For example, if a project deadline cannot be met, use a milestone trigger to automatically alert (email) the project manager who can address the issue by assigning more resources to the project or adjusting the due date.

You can define milestone triggers for a process to be executed before or after the milestone due date is reached, or define it to be executed when the milestone due date is met.

Example: To create a milestone trigger

Create a [milestone](#) in a Sample process map with the following information.

Milestone Name	Target Date	Trigger Firing Target
Milestone 1	2 days from the time the job is started.	+1 day 0 day -1 day

Create a job on the Sample map at T0 = 12 o'clock on 26.09.2016.

As the milestone target date is 2 days from the date the job was created, the target date will be 12 o'clock on 28.09.2016 (the business calendar is off).

- If the milestone is not achieved, a trigger is executed on the following dates:
 1. 12 o'clock on 27.09.2016 - for a trigger execution target of - 1 day
 2. 12 o'clock on 28.09.2016 - for a trigger execution target of 0 day
 3. 12 o'clock on 29.09.2016 - for a trigger execution target of + 1 day

- If the milestone is achieved, for example, on 18.00.00 27.09.2016 (6 hours after the 1st trigger is executed), only the first trigger is executed on 12.00.00 27.09.2016 because, at this time, the milestone was not achieved. The second and third triggers are not executed, because the milestone was achieved before the second and third trigger execution target dates.

The actual trigger execution date also depends on the monitor interval time. For example, if the monitor is configured to check every hour, and the last time the monitor checked the system was 12.20 and the trigger execution date falls on 12.30, the actual trigger is executed at 01.20 (the next time the monitor checks the system).

Activity triggers

An activity trigger is set up against an activity due date.

There could be numerous reasons for an activity becoming overdue. The assigned resource may be overloaded with work or may be sick. Timely escalation helps in acting on time.

An activity trigger is executed when the period relative to the activity due date has passed and as soon as the activity becomes pending or is taken. However, you can set the activity trigger to execute before the activity due date is reached. A trigger cannot execute for an activity that is either complete or on hold. For example, you may need an alert 2 days before an activity due date if no resource is picking up and completing the activity (which means the business process is not progressing as it should).

Example: Trigger to notify the customer

Create the following triggers against the Notify Customer activity in a Loan Request process map.

Activity	Due Date	Target Firing Date	Escalation Process
Notify Customer	12.00.00 28.09.2012	-1 day	Loan Application
Notify Customer	12.00.00 28.09.2012	0 day	Loan Application
Notify Customer	12.00.00 28.09.2012	+2 days	Loan Application

- If the Notify Customer activity becomes pending at 12.00.00 26.09.2006, the trigger executes on the following dates.

A	27.00.2006 at 12.00.00 - when the trigger firing target duration is -1 day
B	28.09.2006 at 12.00.00 - when the trigger firing target duration is 0 day
C	30.09.2006 at 12.00.00 - when the trigger firing target duration is +2 days

- If the activity is completed after the first trigger is executed, or after 27.00.2006 at 12.00.00, triggers B and C are not executed.

Predictive model

Predictive modeling is a statistical technique used to predict the likelihood of an outcome.

For example, the success of a sale may depend on certain factors, such as the value of a sale or a product type. Using a predictive model, you can analyze data from within a process and use the insight to prioritize tasks and make decisions to achieve the optimal outcome for your business.

For example, in an insurance company, a process is dedicated to selling insurance. From previous experience, the company knows the success rate is higher when younger males are targeted. To increase the chances of meeting the sales target before the end of the quarter, the company defines a model to calculate a score that helps prioritize where the insurance can be sold successfully.

Each model consists of several variables (predictors) that are likely to influence the outcome, and the corresponding weighting and scoring to work out the statistical model.

Example: To illustrate the use of a predictive model

1. Define three process variables: Score (Long), Gender (String) and Age (Long).
2. Create a model based on Gender and Age, to calculate score when the age falls between 25 and 30 years.
3. Define value/range and weight for the variables as given in the following table.

 You can add variables multiple times and give a different weight depending on the value or range.

Process variable	Value/Range	Weight
Gender	Male	2
Gender	Female	1
Age	Less Than 25	4
Age	Greater Than 25 and Less Than or Equal To 30	3
Age	Greater Than 30 and Less Than or Equal To 50	1

4. Define the scoring system by creating a score rule as: $\text{Gender} + (\text{Age} * 2)$
Thus, the score for a male, aged 26 is 8 and the score for a male, aged 18 is 10. This resulting score can be used in decision logic and work allocation rules to direct high-scoring insurance requests to the right reviewers, thus increasing potential revenue to the company.

Access

Configure availability and functional access of a process.

Available from and Available to

Allows the process to be activated or deactivated on a particular date.

If set, the process expires as soon as the active period is over. Otherwise, it remains active. For example, a garment retailer decides to implement a discount scheme for Christmas and creates a process map that begins at the start of the season and expires at the end of the season.

Job creation form

If "Update process with associated form" was selected at the time of generating the Create new job form, then the name of the generated form appears in the Job creation form field by default. To associate a different Create new job form either select a different form or provide a static value.

Help text

Information about the process. The text can be added either as **Plain text** or as a **URL** to a web page.

Owner

An owner of the jobs created on a process. You can specify a process owner at design time. An owner is a static resource, which can be an individual resource or a group. Only one resource can be the owner at a time.

If you specify a process owner during process design, the owner of the job is set to that resource. Otherwise, the owner defaults to the resource that created the job.

The job owner can be used to dynamically assign resources to activities. You can also search for jobs belonging to that owner.

For example, in many organizations, resources have the responsibility for jobs regardless of who, among them, performs or completes the work; the job owner functionality can give the owner resource visibility of jobs they are interested in.

The job owner can be changed at any time during the lifetime of a job by the current owner or the supervisor of the owner.

Maintenance access

A resource with maintenance access permissions for a process map can add or delete resources or change the access rights of resources to maintain the system depending on the access types.

You can assign more than one group or resource to a process and set their level of access.

The maintenance access includes the following access types.

Option	Description
Full control	Users with this access type can modify the process and set and modify access permissions for other users. By default, Everyone group has Full control.

Option	Description
Read write	Users with this access type can modify the process but cannot change access permissions.
Read	Users with this access type can only view the process; they cannot modify the process or set and change access permissions for other users.

Default settings

Configure the default resources and notifications for activities at the process level.

Activity defaults

Specify default resources so that you do not have to add resources to each manual activity separately. Whenever a new activity is added to a process, the default resources are automatically added to that activity. The default resources can be individual resources, groups, roles, or a combination of all.

By default, the Everyone (Group) is the default resource for activities. To change the default resource, perform the following steps.

Activity notification defaults

An activity notification is a way of notifying a resource through email that work is ready in an activity and is pending in the queue. When a job is created on the process, an email is sent to the usable resources of the activity for which activity notification had been enabled.

You can set an activity notification for a process as well as an activity. When set for a process, any manual activities added thereafter inherit the settings. When set for an activity, the settings apply only for that activity.

You can create the content of the email, such as the subject and body, and embed a URL in the email to take the user directly to the work. For example, set an activity notification on the Validate Loan Form activity that alerts a Banking officer to check the details on a loan application. A URL embedded within the email launches the relevant web page or job with the customer's details, so the officer can approve or reject the loan application.

 An activity notification only works if the SYSTEM Process Email Activity process map is installed. See [System processes](#).

Process variables

Allow variable prefixing to identify whether the variable is a process or case variable.

The variables are prefixed in the following manner:

- A process variable is prefixed with p. Example: pSessionId.
- A case variable is prefixed with c. Example: cSessionId.

Case completion

In practice, several associated jobs may be running as part of a case. When a case is completed, it impacts the associated jobs. You can configure a case to define the flow of associated jobs on case completion; for example, kick off a separate business process to invoke a formal closing procedure.

You can configure a case to either terminate or leave all associated cases (jobs) running upon case completion. For example, if a court decides that compensation must be paid to all case plaintiffs on completion of a legal case, then the legal case can be configured to keep the jobs alive so that arranging payments can be kicked off for each of the plaintiffs. If the jobs are terminated, plaintiffs are not paid.

 All associated jobs must be completed before the case completion event is executed.

When a case is terminated, all jobs associated with the case are also terminated.

History, reporting and execution

Configure process to record the history of data, and reporting and execution properties.

History

Record history

Records history of data, such as activity taken and completed. See also [Archive finished jobs](#).

Retain indefinitely

Allows to set the period of retention for any instance of the process (including case and case fragment) for a specific period or indefinitely.

- By default, the system retains the process for a period of six months. To retain the process for a specific period, configure the retention period in years, months and days (default: 0 year, 6 months, Minimum value: 1 day). The jobs are automatically deleted once the retention period is over.
- To retain the process permanently, select **Retain indefinitely**.



- Deleting is a non-recoverable action.
- When you import a process from an earlier version of TotalAgility, the retention setting from the earlier version is retained.
- On upgrading TotalAgility from an earlier version, the retention setting remains the same as it was previously set before the upgrade.

You can configure the retention policy only at the system level.

Reporting

The Reporting properties help in data analytics.

Include in analytics

Allows the data related to jobs for a process to be picked up by Tungsten Analytics for TotalAgility reporting so that process data can be analyzed.

Reporting tag

Allows a reporting tag to be added to a process. This enables Tungsten Analytics for TotalAgility to apply a custom filter on a report.

Capture process

Allows the process to be considered a capture process so that the data within Tungsten Analytics for TotalAgility reports can be used to filter the data returned.

Execution

The Execution properties help in controlling the execution of activities and allowing external assembly components to be used within a process.

Thread pool

Thread pool to associate with the map so that the execution of several concurrent activities can be controlled. See [Thread pools](#).

Max loop count

Allows you to define the number of times an activity can be executed in a synchronous job or business rule (default: 1000).

Continuous looping in a synchronous job or business rule can cause a high workload on the TotalAgility server. Maximum loop count helps in reducing the workload on the TotalAgility server.

.Net assemblies

The .NET assemblies to associate with the process so that the process can use external assembly components.

Exceptions

An exception is a way of escalating to the user when a particular situation arises within the running of a process.

For example, an exception is raised if the system is unable to connect to a remote server to download important data, or if no resource is available to pick up a particular job.

You can handle an exception by assigning a process map as an escalation process. For example, configure an Insurance Premium Policy process to automatically send an email if customers do not submit their insurance premiums by the due date.

TotalAgility provides predefined exception-handling codes. Each exception code is a placeholder for a particular type of exception (process map). You can use these processes in your map to address unexpected events, such as throughput, capacity, and workload changes, without manual intervention or process termination.

You must create the process map to run whenever the exception code is called. For example, the exception code EXP0001 is called whenever a resource has been inactive for an excessive period.

Some of the most frequently used examples of exceptions:

EXP0013—Activity Due: Triggers whenever an activity due date is passed.

EXP0005—Job Duration Overrun: Triggers whenever a user takes longer than expected to complete a job.

The maps associated with predefined exception codes belong to the following categories.

- **Workload exception maps:** These maps can handle business exceptions, such as costing or timing that run outside normal business tolerance, such as job duration overrun or activity overdue.
- **System fail exception maps:** These maps run when some element of the system process fails. For example, they might run if a connection cannot be made to a remote server to download information, or if a script object fails to execute.

Process associations

A process map, form, or milestone may be used within a process or by several process maps.

For example, in a map, a variable may be used as an initialization parameter or as a dynamic expected finish time for a job. In an activity, it may be used as a dynamic resource variable or as an output parameter. Similarly, in a map, a milestone may be used in expected duration or as a relative milestone, and in an activity in the target due date or as a milestone to reach when an activity becomes available or completed. If you change or update any of these items for one process map, it may impact several others.

View an association to find out:

- Processes that use the current process.
- Processes being used by the current process.
- Forms being used by the current process.
- Server variables being used in a map or an activity.
- Resources being used by the current process.
- Capture items being used by the current process.
Capture items include Classification and extraction groups, folder types, and separation, scan/VRS, PDF and document conversion profiles.
- Milestones being used in a map or an activity.
- Integrations used by the current process.
- Data models used by the current process.

Associations provide visibility across the entire process map, helping you to manage and maintain your process maps more efficiently.

You can only view associations for a saved or released map.

Process documentation

You can document a process for a wide range of purposes such as auditing or as educational material.

As different users require different levels of information, you can choose the level of details to include before generating the process documentation.

The generated document is created in Microsoft Word format and includes a cover page that contains the item name and version, a table of contents followed by the image of the process map and appropriate sections for each process and the nodes within it.

The document includes information input during design, such as resources, activities, and associated parameters.

Test plan

You can test the process flow for all outcomes and scenarios to ensure the process is compliant to function as intended.

You can create a test plan for business processes, case definitions, fragments, business rules, and custom services.

For full coverage of testing, you must do the following:

1. Identify each independent path in a business process to derive the minimum number of node-tests required to test the business process completely.
2. Create a test for each path.
3. Set data and add assertions to check whether the items being tested are correct.
4. Once the test is defined, invoke each test to execute and display the results.

You can include the test plan when exporting an individual process and import it if they are part of the ZIP file.

Case definitions

A case definition is a complex workflow that can require user interaction and contain decision points, embedded processes, and fragments.

A case definition can involve several complex processes running across several departments and using multiple sources of information. For example, processing an Appeals case could consist of a wide range of documents or forms and numerous processes such as Registering an Appeal, Setting Up a Tribunal Session, Checking Medical Records, and Clearance of an Appeal. These business processes may run independently of one another yet be related to one case (Appeals).

A case process can contain a base case process used to support the overall case, as well as several normal processes or fragments, all of which are linked for collecting and sharing case-specific information.

 A normal process and a fragment can be associated with a case, gaining access to all case-specific data such as milestones and roles.

You can set up and use the following for a case map:

- Milestones or key target dates such as a hearing date within 14 days of the initial registration date of an Appeal case.
- Roles (resources) to complete activities within a process such as Appeals Officer or Legal Representative in the Appeals case fragment.
- Variables to store information specific to a case. This information is then readily accessible and available to all fragments including the normal business processes associated with a case.

Fragments

A case fragment is a sub-process that is initiated and used within a case process and cannot be used by other processes or cases. For example, a patient is represented as a case process and the diagnosis is considered as a case fragment. The diagnosis case fragment is completed if the patient takes the tests, but the case process is completed when the patient is discharged from the hospital.

- A case fragment is like a process in that it has all the attributes of a normal process such as nodes, data, SLAs, and resources. However, a fragment is dependent on the case in which it is created and cannot be reused by other processes or cases.
- A case fragment inherits the properties of the case from which it is called.
- A case fragment has direct access to case elements such as variables and milestones.

For more information on fragment versus process, refer to "Fragment versus process" in *Tungsten TotalAgility Best Practices Guide*.

Process versus case

Some key similarities and differences exist between a normal process and a case.

- The runtime instantiation of a case is a case fragment, which is like the relationship between a job and a normal business process.

- A normal business process (which is based on a Process map) runs through a set of steps in a specific, fixed order from start to finish.
- A case has a base process that gives a general flow to what must be achieved but does not necessarily execute in a logical start to finish fashion. It is tied to the case information through a case ID and not a process map.
- A fragment can be kicked off at any point in the lifetime of a case; therefore, it is not tied to a specific starting point in the process or to a process map.

For more information on case versus process, see "Case versus process" in *Tungsten TotalAgility Best Practices Guide*.

You can generate cases and case fragments using Generative AI.

Business rules

Business rules can be used to build complex business logic without programming and automate and optimize business decisions.

For example, a store offers the following discounts:

- 5% for purchases between £100 and £1000
- 10% for all purchases above £1000

You can use the following logic to calculate the amount to pay after the discount:

```
IF Amount >=100 and <=1000 THEN Discount =5%
IF Amount > 1000 THEN Discount = 10%
Else Discount = 0%
Amount to Pay = Amount - (Amount/ 100) X Discount
Return Amount to Pay
```

A business rule is a diagrammatic representation of a rule and enables you to use all the backend integration capabilities of TotalAgility to retrieve data from external sources to use within the rule. A business rule also enables you to use the decision and multi-branching rules logic of a process map to create the rule and determine the output values.

A business rule includes the following elements:

- Inputs
- Rule conditions
- Output

For more information on business rules maintainability and testing, refer to "Business rules" in *Tungsten TotalAgility Best Practices Guide*.

Business rule types

You can design the business rule based on the following rule type:

- [Flow rule](#)
- [Decision tree](#)
- [Decision table](#)
- [Work queue automation](#)

Flow rule

A flow rule allows you to create a complex rule that uses all the backend integration capabilities of TotalAgility to retrieve data from external sources to use within the rule. A flow rule also enables you to use the decision and multi-branching rules logic of a process map to create the rule and determine the output values.

A flow rule is, in a way, a guideline or condition that dictates how a specific business process should be executed to ensure that tasks are carried out consistently and efficiently within an organization.

For example, in an "Order Processing" flow rule, the orders are processed based on the following two conditions:

1. If the total order value is greater than \$1,000, the order must go through a supervisor's approval before it can proceed to shipping.
2. If the total order value is \$1,000 or less, the order can bypass the supervisor's approval and proceed directly to the shipping department.

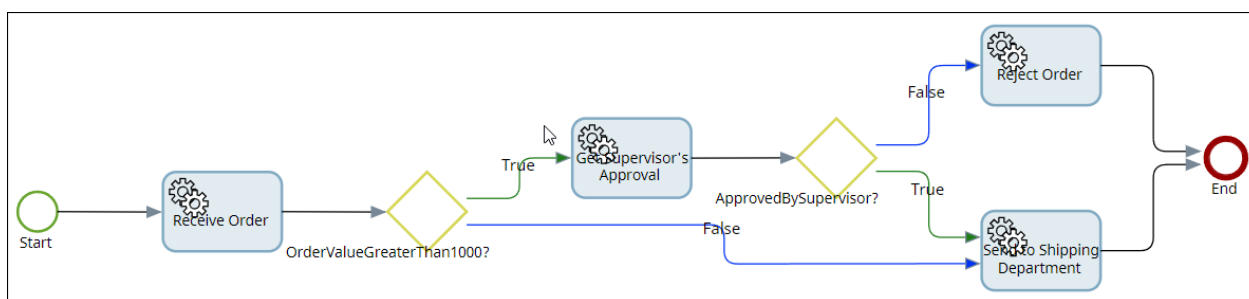

When a new order is received, the system calculates the total order value.

- If the order value exceeds \$1,000, the system triggers an alert/notification to a supervisor for approval. The supervisor reviews the order and either approves or rejects it.
- If the order value is equal to or below \$1,000, the system sends it directly to the shipping department for processing and fulfillment without the supervisor's intervention.

Thus the "Order Processing" flow rule helps the company manage risk and ensure that high-value orders receive appropriate oversight to prevent errors or fraud. At the same time, it streamlines the processing of lower-value orders, improving operational efficiency.

You can create a flow rule either designing a flow or generate it using Generative AI.

Decision tree

A decision tree allows you to structure the rule in a much more readable fashion. You can define conditions and paths easily. A decision tree considers all possible outcomes and traces each path to a conclusion. It visually presents all the decision alternatives for quick comparisons in a format that is easy to understand with only brief explanations.

A decision tree is displayed vertically with rectangular nodes with text available on the paths making the logic easy to read and maintain.

You can debug and test a decision tree to test and modify the logic.

You can create a decision tree either designing it or generate it using Generative AI.

The following is an example of decision tree to determine eligibility based on age.

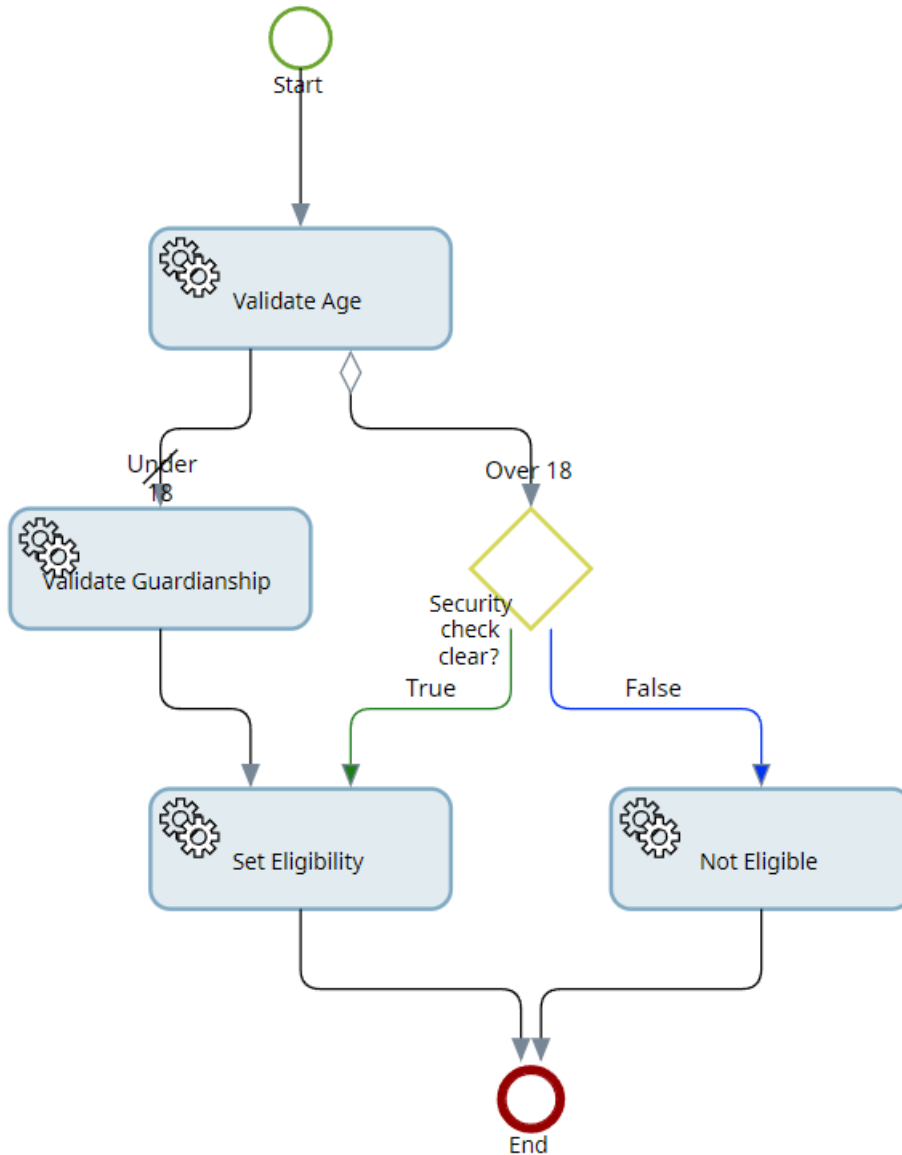

Decision table

A decision table is a concise structural rule where each row represents a condition with an outcome. Technical Developers can define the input and output for the rule and then the Citizen Developer can modify or add the logic. This collaboration greatly extends the scope of who can do the development and management of rules. A decision table is made up of inputs, outputs, conditions, else conditions, and hit policy.

The following is an example of determining the applicant's risk rating based on a combination of their age and medical history.

F	Applicant Age	Applicant Medical History	Applicant Risk Rating	Comments	+
1	<25	Good	Low		✎ + 🗑
2	<25	Bad	Medium		✎ + 🗑
3	25 - 60		Medium		✎ + 🗑
4	>60	Good	Medium		✎ + 🗑
5	>60	Bad	High		✎ + 🗑

> **Decision table**

Name* Applicant Risk Rating

Description Determining the applicant's risk rating based on a combination of their age and medical history.

Type Decision table

Category* Default Category x

Hit policy First found

Include else condition

- If the applicant is less than 25 years and medical history is good, then the risk rating is low.
- If the applicant is less than 25 years but the medical history is bad, then the risk rating is medium.
- If the applicant is between 25 and 60 years but has no medical history, then the risk rating is medium.
- If the applicant is greater than 60 years but the medical history is good, then the risk rating is medium.
- If the applicant is greater than 60 years but the medical history is bad, then the risk rating is high.

Work queue automation

The automated work queue management feature provides the ability to define rules that can complete a manual activity or change who is assigned the activity.

Based on certain conditions being satisfied, you can do the following:

1. Complete a manual activity automatically, on behalf of someone or by the system.
2. Update the resources on manual activity to a more appropriate user or group, on behalf of someone or by the system.

Automatically complete a manual activity

In TotalAgility, an activity can be manual (requiring a user to perform it) or automatic (where the system performs it).

Some manual workflow tasks can be repetitive.

- Always approve leave requests that are half days.
- Accept loan approvals where the amount is < \$1000.
- Complete an activity that is just an acknowledgment and does not require any data to be entered.

If each worker must complete one of those tasks daily, and it takes one minute to complete then if they can automate that task, the worker can save 30 minutes monthly (6 hours annually).

If you apply that across a whole organization, then the hours saved increase significantly thus allowing the workers to focus on higher-value tasks and achieve greater overall efficiency and effectiveness.

The work queue automation feature allows users to request automation on the tasks assigned to them. If the automation request is accepted (via the process feedback feature), a work queue automation rule can be configured in the process designer to auto-complete tasks on that user's behalf under certain conditions.

If on a particular process, users continually request the same automation, then you can redesign the process to perform one of the following:

- Partially automate by adding logic into the process to bypass the step under certain conditions.
- Completely automate that manual task using the information garnered from end-user requests.
- Remove the task completely if it is not adding any value.

Auto-completion is typically configured to complete on behalf of a user; however, auto-completion can also be configured to run regardless of the user, at a system level. For example, you can configure a work queue automation to automatically reject all loan applications where the requester has a low credit score. For this task, you can set up a rule to filter out tasks that do not meet business goals and are considered a wasted effort to manually review and eliminate. Then hold the credit score as business data and update it as and when needed either using the decision table or by calling a process. In this case, the system (TotalAgility) completes the manual activity.

When an activity is completed automatically, auditing and the history of the job will indicate this.

Update the resource assigned to a manual activity

A work queue automation rule can determine the resource (user or group) best suited to complete an activity based on some conditions and update the resources assigned to the activity if a rule match is found.

If a leave request is for more than 20 days, then the HR group is responsible for approving this rather than the requestor's line manager.

When resourcing is changed via a rule, auditing and the history of the job will indicate this.

Benefits

Benefits to automated work queue management include:

- Saves time by automatically completing repetitive activities based on known inputs and outputs.
- Supports hybrid mode of work completion where the activity is typically completed manually but can be completed automatically in an unattended manner using conditional logic.
- Allows routing work automatically to more appropriate resources.
- Allows maintaining rules independently from the process by the Technical or Citizen developer.
- Decouples the logic for completing or routing from the process itself.

Difference between decision table and decision tree

The following are the differences between a decision table and a decision tree.

	Decision table	Decision tree
Representation	Uses a tabular format with rows and columns.	Uses a graphical tree structure with nodes and branches.

	Decision table	Decision tree
Complexity handling	More suitable for handling complex combinations of conditions and actions.	More visual and intuitive but can become complex with many decision points.
Readability	Easier to read for complex scenarios with many conditions.	More visual and may be better for illustrating a simple sequence of decisions.
Space efficiency	More space-efficient when dealing with a large number of conditions and actions, as they use a compact tabular format.	May become visually cluttered in such cases.

Skins

Business Process Outsourcing enables organizations and Shared Service Centers that have several core processes to have many views of the same process typically for different products and customers.

When processes have the same structure but different rules on resourcing, SLAs, and others, then skins allow you to create different variants of the process without having to manage and maintain separate copies of the process. This greatly reduces the maintenance overhead and allows changes to the template to be immediately reflected across all skins.

For example, if for a gold customer, the process needs to be completed in one day and for the silver customer it needs to be completed in two days, OR if the process is critical, it must be routed to a specialized group, otherwise, to a general group, then you can create two variants of the same process.

You can tag skins so that you can add some text to describe what the skin is about and make it easier to find.

Templates

A process can be marked as a template. Once set as a template, you can create skins on it. Any changes to the template are automatically applied to each skin.

i Skins always apply to the latest version of the process.

Within a skin, you can override the properties of the process, variables, and activities.

i If there is a part of the process that might require structural change, you can achieve this by using embedded processes, as the embedded processes can be overridden in a skin.

Rules

Skins are invoked based on the defined skin rules. For example, for a gold customer, gold skin is used, and for a silver customer, silver skin is used.

When a job is created on a template, the rules are evaluated. In case of multiple versions of skin, the job must be created on the latest active version of the skin. The first rule that evaluates to true uses this skin and any overrides set for the skin are used. If the rule does not evaluate to true on this skin, it moves to the next skin and so on until the rule is passed. If no rule evaluates to true, the process continues without any overrides.

During the lifetime of a job, the skin can be reevaluated. For example, when the data changes, this could potentially invoke a different skin or no skin.

Custom services

Custom service is a business process type that enables you to provide custom logic that can be made available for use within a process, business rule, case definition, or form.

A custom service only supports automatic activities; it does not support manual activities. You cannot turn on business rule logging for custom services.

You can create, copy, modify, delete, unlock, and tag a custom service.

You can generate a custom service using Generative AI.

System processes

A few fully customizable system processes are installed with TotalAgility on-premise to support features in the product.

SYSTEM Active Directory Synchronization

Use this map to synchronize the Active Directory (AD) resources with TotalAgility. This map synchronizes organizational units and their associated groups and users within the Active Directory; it does not synchronize any containers, objects, or users outside of an organizational unit.



- TotalAgility Active Directory synchronization is passive. It cannot add, update, or delete anything in Active Directory. As an added security measure, it obfuscates the Object ID from Active Directory to store it as a Resource ID in TotalAgility (HEX conversion). You cannot locate the same resource in Active Directory even from the Resource ID from TotalAgility.
- TotalAgility Integration server does not support the Active Directory Synchronization system process.

SYSTEM Check for Completed Delegations

Use this map to remove redundant work delegation rules after their end date has passed.

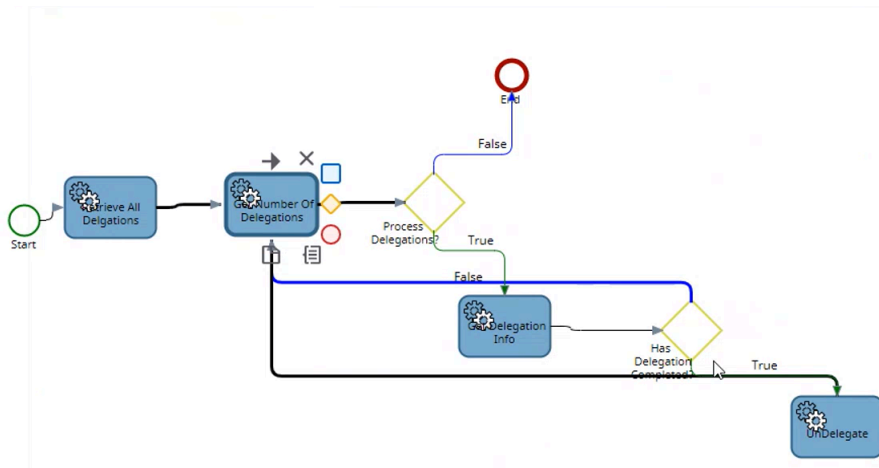

A scheduled job is run on this map each night at one minute past midnight to check for and delete redundant delegations.

SYSTEM Passcode Notification

When multi-factor authentication is enabled use the SYSTEM Passcode Notification map to send a passcode to users for authentication when they login to TotalAgility for the first time



The email node within this map is configured to send an email with descriptive text and a randomly generated passcode to the user.

SYSTEM Perform Auto Work Allocation

Use this map to allocate the activities that are awaiting allocation for the current day to appropriate resources with AutoWorkAllocation debits.

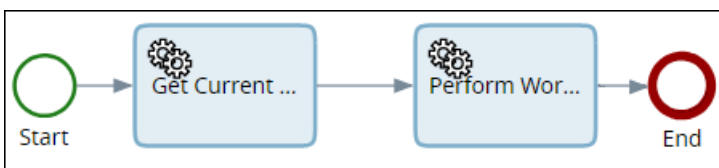

System Process Email Activity

Use this map to process email notifications when activities are pending.

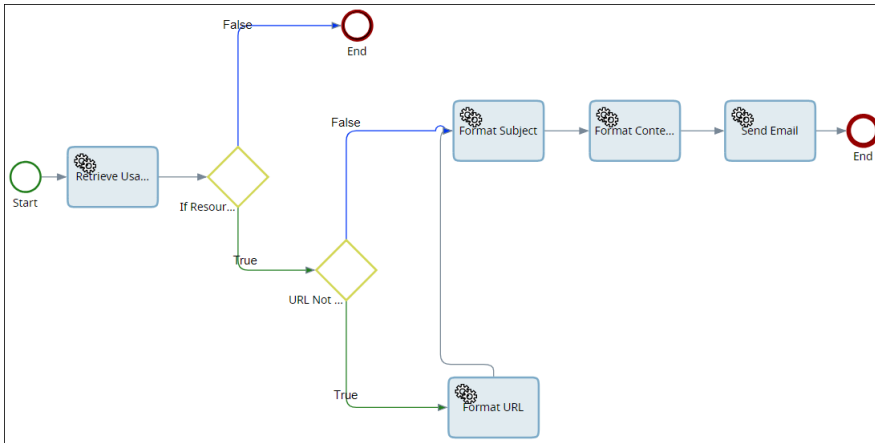

The server variable `SYSTEM_EMAIL_FROM` is imported into the system with this map. Update the default value with the email address of the user who sends the email notifications in your organization.

Use the email node to specify whether to send an email to all usable resources when an activity becomes pending. Define the structure of the email including the subject, content, and a URL for an ASP page that takes and completes the pending activity.

i Ensure that you generate this ASP page and place it in the following folder `C:\inetpub\wwwroot`.

SYSTEM Reset Password

Use this map to send an email to the user email address to reset password.

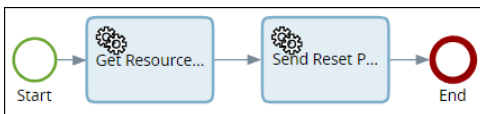

SYSTEM Reset Quantity Counts

Use this map to reset all checking and sampling counts to zero.

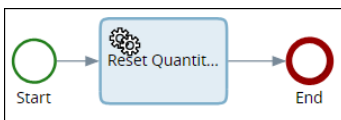

Save and release processes

Once you complete the design of your process map, you can save or release it. You can only start a job based on a saved process map, if you have a development license.

- Saving the map saves map changes and creates a minor version of the map, such as Get Customer Details v0.01.
- Releasing the map saves and releases the map, and creates a major version of the map, such as Get Customer Details v1.0. You can only use a released map in production.

You can control the release of a process using the OnRelease event. To handle the release, you can:

- Create a new process, such as Approve Loan Application Release process.
- Add activities to the event handling map to take whatever steps are required before the map can be released, such as notifying someone or getting approval.
- The event handling map must release the map after the release business logic is completed.

 Use an API call to the ReleaseProcess method available in ProcessService SDK.

Revert and delete processes

You can revert a process map to a previous version and also delete processes.

Revert processes

Revert a process map to create a new version of the map based on an earlier version. All the items including variables, activities, resources, properties, and skin rules of the selected version are available in the newer version. For example, in a management scenario, as part of the company's project plan, you might have altered the organization's hierarchical structure, resource managerial levels, their categories and also the process map design. Then saved and released to create a new version of the map and immediately put it to use. However, after few days of implementation, management analyses the performance and opts to revert to the previous resource hierarchy and process flow. You might then want to pick the earlier map version and replace the current version.

Delete processes

You can delete latest or specific versions of processes. When you delete specific versions of the process, the selected version and all the previous versions are deleted. For example, if you delete version 3, then version 1 and version 2 of the process are also deleted.

Monitoring

Changing business conditions make it important to recognize trends and patterns in your business performance for proactive and informed decision-making.

Business events are key events that business users monitor and manage, such as cases open, sales made, sales lost, and claims settled. A business uses events to monitor performance against targets. For example, you define a Sales event that records the name of the salesperson and the total sale amount. When the salesperson completes a sale, the system fires the event, which is in the sales process.

Each salesperson in the team could have different quarterly targets. You can create a business target for each salesperson, based on the Sales event, and monitor the event every quarter. In the target value, enter an amount as the goal for the salesperson, and in the filter criteria, use their name. Repeat this for each salesperson to configure a business target for each one.

You can define business alerts to notify the system when the sum or occurrence of an event reaches a specific value. For example, for a Sales event, create an alert that runs when a salesperson reaches double their target. The alert can create a job to send a congratulatory email.

Tungsten TotalAgility can monitor targets and automatically initiate business processes if thresholds are missed.

A process, form, or business rule can initiate these events.

You can associate the event with an activity and export and import business events, targets, and alerts.

Business events

Use business events to monitor business performance, either independently of processes, or through a process that initiates an event.

Business alerts

A business alert is an automatic action that occurs when a target threshold is met.

The alerts are business processes that can be as simple as an email interaction, or as complex as a change to operational parameters.

Business targets

A business target is a goal against which you can monitor a business event's performance.

It defines how a business monitors the collection of key business events.

Chapter 4

Model the user interface

TotalAgility lets you model forms that provide the user interface to support your processes. You can manually create forms, build forms based on business processes and preview forms.

You can also create mobile and tablet versions of forms and make forms touch enhanced.

Generate forms automatically

Create forms automatically to include TotalAgility functionality without the need to design them. These forms contain the appropriate controls and actions to support your solution.

The following forms are available to generate automatically.

Create new job form

A Create new job form helps you create jobs. Controls are added for all initialization parameters and the Create new job event is configured.

Scan create new job form

A Scan create new job form not only creates the job but also enables documents to be scanned and associated with the job.

Device create new job form

A Device create new job form provides all the capabilities of the scan create new job form only for use on a mobile device or MFP.

 The MFP forms can be accessed only from Lexmark MFP devices. Only Tablet version (default) of the forms can be created.

automatically.

MFP Scan create new job form

A Scan create new job form allows to scan documents and create jobs on MFP-friendly scan activities.

Document form

A document form is a customized view of a document. Using a Document form, you can generate Scan, Validation, Verification and Document Review forms for a document type. A Document Type can have more than one form. However, a Document Type can have only one of each form type.

Folder form

A folder form is a customized view of a folder. Using a Folder form, you can generate Scan, Validation, Verification, and Document Review forms for a folder type. A folder type can have more than one form. However, a folder type can have only one of each form type.

Logon form

A custom logon form generated automatically without creating an external web page that you then redirect to your site. This form can use Windows Authentication, Federated Security or manual logon.

A logon form using Windows authentication or Federated Security uses the ID of the user who is logged on for authentication. A logon form that uses manual logon requires the user to enter a username and password (optional).

Activity form

The Activity form helps you generate forms for all ordinary and capture activities of a process map. Type-specific controls are added for input and output parameters for the activity along with the Take activity, Complete and Cancel activity events.

Multiview form

A multiview form enables users to view different forms without navigating away from the primary form. A multiview form works like a container that shows other related forms within it. A user can switch between the pages of a multiview form using a navigation menu. Switching between pages preserves the state of the page. When a user navigates back to a page using the menu item, the page appears exactly as the user left it.

Multiview activity form

A multiview activity form allows you to display a primary form and navigate to other forms while maintaining context. Use this form to build forms for multiple activities and to display those forms with additional content using a navigation menu.

MFP form

A custom form that is available for use only on a Multi-Function Peripheral Lexmark (MFP) device.

MFP work queue form

A custom work queue form with the display detail or work type specified. This form only displays the MFP-friendly activities.

MFP activity form

An MFP activity form automatically generates activity forms for MFP-friendly scan and ordinary activities.

Manually create forms

Create forms manually if you want full control over the layout and functionality to be included within it.

Creating a form manually gives you more control and flexibility over the resulting Windows when compared to those created automatically. Plan your form design before creating a new form to save time and effort.

- Insert a table framework before adding controls to the form.

- In the framework, include rows, columns, and cells for organizing and arranging form content.
- Include sections and controls.
- Include logos, and other types of graphics.
- Supply a label for a field even if you are not showing the label on the form. Labels help end users know which form fields have failed validation.

Refer to the "Solution building > Building forms > Design guidelines" section in the *Tungsten TotalAgility Best Practices Guide*.

You can do the following:

- Create a Desktop, Phone, or Tablet version of the form with the additional option of making the phone or tablet touch enabled so that the user experience can be customized to suit each device.
- Switch between form types if they exist. If a particular type of form does not exist, switching to that icon creates a blank version of the form. For example, if you switch to the phone icon, and if that form does not exist, a blank version of the phone form is created.
- Generate a form using Generative AI functionality.
- Create a custom form for use on a Multi-Function Peripheral (MFP) Lexmark device. You can only create the Tablet version (default) of the MFP form.

Toolbox

Define the layout of a form and add controls to it.

You can enter information into a form by typing into text boxes, selecting items from a list, selecting check box options, and performing other actions. The objects with which users interact are called "controls".

Some controls, such as buttons, allow you to execute an event that performs an action. For example, clicking a button at the bottom of a form can save the input information to a database.

In some controls (on all forms), the input element's name is not populated, and using methods that rely on the underlying DOM may cause issues. In such cases, you must use Ext APIs, such as `Ext.getCmp()` to access the controls. For example:

```
var myCheckBox = Ext.getCmp('checkbox1'); "
```

The toolbox includes basic layout elements (columns, rows, and cells), and general and advanced controls that help in designing your user interface. It also includes form templates, if configured.

When a form control and a form variable have the same name, the form control name takes precedence over the form variable name in the actions and at runtime.

Layout

Columns, rows and cells help in arranging your form content.

Column

Use columns to divide a form vertically into equal parts. For example, if you add one column, the form is divided into two equal parts; if you add two columns, the form is divided into three equal parts.

Row

Add rows to horizontally divide the form into panels.

Cell

Add cells to create sections in a form.

General controls

TotalAgility supports the following basic form controls.

Label

Use a Label control to add descriptive text to a form.

Textbox

Use a Textbox control to create a text field where a user can enter information on the form. Also use a text box to display information, such as the result of a formula or the current date.

Multi-line text

Use a Multi-line text control to create a text field that can handle the text that may go beyond one line. For example, a user can enter information on the form, such as a customer address.

A Multi-line text control is available for a Desktop, and Phone or Tablet (touch-enhanced and non-touch) form. This control is supported on all forms except for the Device create new job form.

Button

Use Button controls to allow users to perform actions, such as submitting a form, querying a database, or approving a loan.

Button controls have a predefined set of events that can be invoked when a user clicks a button.

Checkbox

Use a checkbox control to select a particular option from several independent choices.

Table

Use a Table control to organize and arrange information or data into rows and columns.

Dropdown list

Use a dropdown list to ensure that the data entered is valid and to help the user complete a form with the responses that the designer intended.

A drop-down list contains a set of predefined (and usually common) options that can be static (hardcoded), retrieved from a table that is bound through a data connection to a table in a database, retrieved from a lookup, or redirected from another form.

Calendar

Use a Calendar control to help users enter correct and valid dates.

Radio button list

Use a Radio button list control to present multiple options that are mutually exclusive and from which the user must select only one. For example, in the Marital Status radio button list, if the Married radio button is selected, the Single, Divorced, and Widowed radio buttons are cleared.

Tab

Use a Tab control to group related information on a form. You can configure multiple tab controls on a form and have multiple tabs in each Tab control. Saving an individual tab control saves all tab details.

To manage the data displayed on a tab, use the Tab loaded event for a tab in a Tab control. The Tab loaded event ensures that the data displayed on the tab at runtime is the data entered in other controls for that tab. The event also optimizes the performance of form loading, because the events are only triggered when the user clicks the relevant tab.

 The events are triggered only once when the user clicks a tab for the first time and not on subsequent clicks. However, events on the first tab of a Tab control are triggered when a form loads because the first tab is loaded and displayed along with the form.

Hyperlink

Use a Hyperlink control to provide a link to a URL on a form. For example, a form displaying information about a list of products can include hyperlinks to other web pages displaying more information about those products. Hyperlink controls can point to any web server on the intranet or Internet.

Image

Enhance the look and feel of your forms by adding icons and images to forms and buttons on forms.

Chart

Use a Chart control to add charts to a form and create a visual representation of data returned from a query. The chart displays a count of items grouped by fields and a total count of items.

 The Chart control is available for Touch and Non-touch forms but is not available for MFP forms.

Tile

Use a Tile control to view the total returned from a query compactly on a dashboard.

List

Use a List control to show a list of items with swipe options on a phone and tablet. You can add multiple List controls and display them side by side by adding them to multiple columns of a form. A List control is only available for a touch-enhanced Phone or Tablet form; it is not available for a Desktop form.

Horizontal rule

Use a Horizontal rule control to enhance the look and feel of a form and denote a change of context. Using Horizontal rules, you can draw lines across the screen to separate sections of a page.

Capture controls

TotalAgility provides the following capture controls:

- Text field
- Check box
- Combo box
- Table

You can open a capture form in the design view and configure these controls.

Mini-viewer

Display a Mini-viewer for a capture field on a Document form to quickly view a portion of the image related to the field. When you choose to show a Mini-viewer for a capture field in a Document form, additional control is added to the selected capture field.

 The Mini-viewer is not available for a capture Table control.

Input types

The input types are the preconfigured quick controls (Textbox) available on the forms toolbox so that you can easily add them to a form.

The input types are available for a Desktop, and Phone or Tablet (touch-enhanced and non-touch) form; and are supported on all forms except for the Device create new job form.

The following preconfigured input types are available:

- **Password:** A textbox control with the Field type set to Password, and the Label text defaults to Password.
- **Email:** A textbox control with the Field type set to Email, and the Label text defaults to Email.
- **URL:** A textbox control with the Field type set to URL, and the Label text defaults to URL
- **Numeric:** A textbox control with the field type set to Numeric.
- **Decimal:** A textbox control with the Field type set to Decimal, allows decimals, and the Decimal precision set to 2.
- **Currency:** A textbox control with the Field type set to Currency and the Decimal precision set to 2.

Headings

Use the preconfigured headings (Label controls) available on the forms toolbox to quickly add to a form.

The headings are available for a Desktop, and Phone or Tablet (touch-enhanced and non-touch) form; and are supported on all forms except for the Device create new job form.

The following preconfigured headings are available:

- **Heading H1:** A label control with the "Label type" set to Heading and "Heading size" set to 1.
- **Heading H2:** A label control with the "Label type" set to Heading and "Heading size" set to 2.
- **Heading H3:** A label control with the "Label type" set to Heading and "Heading size" set to 3.
- **Heading H4:** A label control with the "Label type" set to Heading and "Heading size" set to 4.

- **Heading H5:** A label control with the "Label type" set to Heading and "Heading size" set to 5.
- **Heading H6:** A label control with the "Label type" set to Heading and "Heading size" set to 6.

Advanced controls

TotalAgility supports the following advanced form controls.

<ul style="list-style-type: none"> • Job list • Work queue • Workload • Document set • File upload • Resource tree • Embedded page • HTML • Process viewer • Web capture • Thumbnail viewer • Mobile capture • TCM 	<ul style="list-style-type: none"> • Mobile capture barcode • Case health • Checklist • Language selector • Custom action button • Toolbar • Create new associated job • Summary • Job action button • Activity action button • Generative AI chat
---	---

 A phone or tablet form with the Touch enhanced property only supports the Embedded page and File upload controls.

Job list control

Use a Job list control to allow a user to view, search and perform operations on jobs in TotalAgility.

Configure the control to show a predefined query or enable the user to select and modify the query used to populate the list. You can use a Job list control within forms to display jobs with associated information. The properties and metadata to display are configurable as are the actions to perform.

The Job list control has the following events:

- **Refresh:** This event allows certain actions to be performed on refreshing the control at run time. The Refresh event is specifically helpful when there are tiles or other controls dependent on some controls that need to be updated.
- **RowSelected:** This event enables the form designer to take additional job-related actions based on the selected jobs.

When one or more jobs are selected, the SelectedJob/SelectedJobs, and SelectedCase/SelectedCases properties are populated accordingly. To provide multi-select capabilities, ensure that the "Multi-select" checkbox is selected on the Configuration tab of the Job list control.

Process	SLA (J...)	Due Date	Creator	Priority	Status	Pro...	Actions
<input type="checkbox"/> bgprocess	●	5/17/2024 12:55:47 AM	User1	1	Suspended	1	Select ▼
<input type="checkbox"/> bgprocess	●	5/17/2024 12:55:47 AM	User1	1	Suspended	1	Select ▼
<input type="checkbox"/> bgprocess	●	5/17/2024 12:55:48 AM	User1	1	Suspended	1	Select ▼
<input type="checkbox"/> bgprocess	●	5/17/2024 12:55:48 AM	User1	1	Suspended	1	Select ▼
<input type="checkbox"/> bgprocess	●	5/17/2024 12:55:48 AM	User1	1	Suspended	1	Select ▼
<input type="checkbox"/> bgprocess	●	5/17/2024 12:55:48 AM	User1	1	Active	1	Select ▼
<input type="checkbox"/> np1	●	5/17/2024 12:55:54 AM	User1	1	Active	1	Select ▼
<input type="checkbox"/> np1	●	5/17/2024 12:55:55 AM	User1	1	Active	1	Select ▼
<input type="checkbox"/> np1	●	5/17/2024 12:55:55 AM	User1	1	Active	1	Select ▼

A user can perform tasks on a single job by selecting an action on the job row or perform tasks on multiple jobs or cases at once by selecting an action in the table header.

Work queue control

Use a Work queue control to provide users a means of selecting and completing work.

You can configure the control to either show a predefined query or select and modify the query used to populate the list.

The Work queue control includes the Refresh event. This event allows certain actions to be performed on refreshing the control at run time. The Refresh event is specifically helpful when there are tiles or other controls dependent on some controls that need to be updated.

i Work queue control is not supported on touch forms.

Workload control

Use a Workload control to view the results of a system query.

The query helps you to view the workload for automatic and manual tasks so that you can take action to avoid delays in processing the tasks and improve performance.

When you view the Workload control at runtime, only system queries are displayed in the Queries panel. The list of queries is displayed based on the selected query. When you search for locked or evaluation failed activities, or activities in any other status, the results matching the criteria including the machine name are displayed.

The Workload control includes the Refresh event. This event allows certain actions to be performed on refreshing the control at run time. The Refresh event is specifically helpful when there are tiles or other controls dependent on some controls that need to be updated.

i Workload is not supported on touch forms.

Document set control

Use the Document set control to allow an administrator or customer to have appropriate views and perform operations on the document types and associated documents within the document set.

The Document set control displays the document set at runtime with details of the document types and the documents received.

File upload control

Use the File upload control to browse and upload single or multiple files to the document repository or a specified location in the TotalAgility server.

Resource tree control

Use the Resource tree control to enable resource selection.

Embedded page control

Using the Embedded page control, you can embed an external web page (through a URL), an existing form, or an insight view within a form.

At runtime, when the site is loaded, the embedded web page is automatically opened, enabling you to view multiple pages at the same time.

HTML control

Use HTML control to display HTML content that is returned from external sources, or set inline while designing the form.

At runtime, the HTML content is converted to the relevant HTML format and displayed inside the HTML control.

Process viewer control

The Process viewer is also called the "Job viewer".

 The Process viewer control is not supported for touch-enabled forms.

The Process viewer control serves two purposes:

- Displays the runtime view of the progress of a job (a live instance of a process) highlighting the path taken and the status of the various nodes. Key information is available on each activity, and each activity is outlined in a specific color representing the status. With appropriate permissions, several live properties can be changed on the job. To use the control in this manner, a Job ID must be supplied.
- Displays the design of a process version outside of the standard design environment. With appropriate permissions, several operational properties can be changed. To use the control in this manner, a Process ID must be supplied along with an optional version number.

 If no version number is supplied, the latest version of the process appears.

Web capture control

Use a Web capture control to create, scan and view documents.

The Web Capture Control can display documents from the Capture document repository and the following custom sources:

- Local path on the Web server
- Windows file share
- HTTP GET URL

All types of documents (images and eDocs such as PDF, DOC, XLS, and more) that are loaded from the custom sources are rendered as images if the "Use eDoc rendering" option is enabled in the Web Capture control.

If a document is loaded from the custom source, a few buttons available on the Web Capture control toolbar, such as Save, Delete Page, and more are disabled. See the TotalAgility Web Capture Control Help for more information.

Using a Web capture control, you can do the following:

- Create multi-page documents.
- Create a new document in a new folder.
- Create a new document in an existing folder or subfolder.
- Scan and view a document. Use the document ID to view the document.
- Specify the type of a newly created document or folder.
- Add new pages to an existing document.

 The control lets you add new pages to an existing document but does not let you replace the document.

- View all the pages of a newly created or existing document.
- Delete pages that have been incorrectly scanned.
- Selectively hide specific buttons at design time and only display the selected ones at runtime.
- Undock the image or document viewer from the main form and display it in a separate browser window so that it can be viewed on a second monitor.
- Permanently alter the image, so that you can remove sensitive information that should not reside in your database.
- Add sticky notes.

 The Web capture control is not supported on touch enhanced phone and tablet forms.

Thumbnail viewer control

Use the Thumbnail viewer control to display the thumbnails for the documents that are loaded in the Web capture control.

When you navigate to a page in the Web capture control, the corresponding page is highlighted in the thumbnail view and the control also displays the difference between a selected and currently viewed page.

TCM control

Use the TCM control to interactively generate documents in TCM (Tungsten Communications Manager) through a Tungsten TotalAgility form. To include any previously collected data, you should initialize the control with the data backbone variable from your process.

For example, you can add a manual activity to a process with a data backbone variable as the input or retrieve the backbone variable using the GetJobVariable API in a standard form.

A TCM control has the following modes of operation:

- **Compose:** Create a document based on the selected template from a document pack, document template, or a template from a letterbook (the end user selects the template at runtime).
- **Rerun:** This mode displays the control in a rerun mode. You can modify the previous selections and the documents in the pack are updated on rerun.
- **Review:** Displays the control in read-only mode to allow reviewing of generated documents.

Using the TCM control, you can distribute documents through the TCM server based on the distribution mechanism such as email or print.

Mobile capture control

Use a Mobile capture control to capture an image.

Using this control, you can capture an image to:

- Add it to an existing document.
- Create a new document in a new folder.
- Create a new document in an existing folder or subfolder.

Any document created with this control can be used as part of a Document review activity or a Validation activity.

 This control is only available for a phone or a tablet form, which is not touch-enhanced. It only works when viewed on a phone device in conjunction with the Mobile SDK. If you try to use this control without the SDK, for example, view the form by browsing on a standard browser the control does not work.

Mobile capture barcode control

Use a Mobile capture barcode control to capture a bar code and make the value available for use within a job.

You can only add one instance of the control to a form. When a bar code is detected in the camera viewfinder, the bar code value property of the control is populated, and an event is raised. You can then use the value as needed, for example, to pass into a CompleteActivity call.

This control is only available for a phone or a tablet form, which is not touch-enhanced. It only works when viewed on a phone device in conjunction with the Mobile SDK. You cannot use this control without the SDK. For example, when you view the form by browsing on a standard browser, the control does not work.

i The event only fires if a bar code is found.

Case health control

The Case health control displays the key details of a case and illustrates the overall case status and case progress.

Use a Case health control to view the status of other processes. To do so, pass the job ID for a normal process or fragment into the case health control. When you set the Case/Job ID, at runtime the current state of the selected case or job appears as shown in the image below.



Checklist control

Use a Checklist control to display a list of items to guide inexperienced users through each step in a task.

Use the control in conjunction with sampling and checking for quality purposes.

Language selector control

Use the Language selector control to control the language in which to display the form.

i A form can have only one Language selector control. If a form has multiple Language selector controls, unexpected behavior occurs, and the selected language is not set at runtime.

Custom action button control

Use the Custom action button control to create a button that provides a dropdown list of options or an image list of options.

This button can be used on a form or within a table on a form. Each option can perform an action configured against it. The Custom action button control is available for desktop, phone, and tablet (non-touch) forms.

 For touch, use the existing Show action menu action.

Toolbar control

Use the Toolbar control to group buttons in one control.

This control is available for desktop, phone, and tablet forms. You can define the buttons in a hierarchy, separators, and spacers that appear on the toolbar. Each button can have both text and image, or only text, or only image.

Create new associated job control

Use the Create new associated job control to provide a list of processes relevant to the current job (fragments and associated processes) that can be invoked to initiate an associated job.

Summary control

The Summary control provides an overview of the day ahead for a resource.

Use this control to display the following details:

- A summary of planned hours: Working hours based on a calendar or work pattern, and any debits and credits for the current day.
- Activity status: All pending and overdue activities or the pending and overdue activities for yourself, and the workload.
- Jobs: All pending and overdue jobs for which you are the owner.
- Achievement status: Number of jobs created, activities completed, and the time spent on activities.
- Notifications: Number of alerts and any unread resource notes.

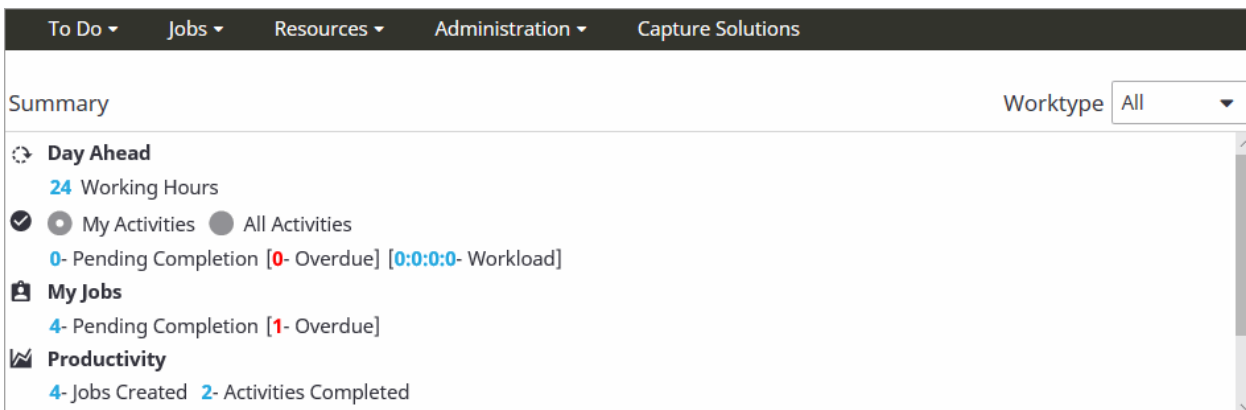

Activity action button control

The Activity action button control provides a predefined set of actions that can be performed on an activity.

It is displayed as a button with an associated dropdown menu. Each menu item represents an action you can perform.

i An Activity action button control applies to desktop, and non-touch mobile and tablet forms.

Job action button control

A Job action button control provides a predefined set of actions that can be performed on a job or case.

The Job action button control is displayed as a button with an associated dropdown menu. Each menu item represents an action you can perform. The list of actions to display is configurable.

No events are available on this control; therefore, you cannot directly associate it with actions.

i A Job action button control applies to desktop, and non-touch mobile and tablet forms.

Capture Composite control

A composite control is automatically added to a Capture form when it is generated using one or more capture activities (Scan, Validation, Verification and Document review) configured in a process.

Generative AI chat control

Use a Generative AI chat control to request the AI provider questions to help complete the activities.

i This control is available only for the desktop forms.

Form initialization

An initialization variable is any process variable for which a value should be provided when the job is being created; the order of the initialization variables is configurable within the Designer.

Create new job forms provide appropriate controls for the initialization variables and the corresponding Create new job event.

When creating a job through a process map, variables can be consumed for the initialization variables.

Form events and actions

A form and each control on a form have a predefined list of events into which you can consume actions, allowing the Designer to react to a user action.

For example, you can retrieve a list of states or counties based on the selected country or save an order when the Submit button is clicked.

Use the following links to know more about form events and actions:

- [Form actions](#)
- [Form events](#)

Form actions

Actions describe different ways to initiate an event. For example, you can base a customer credit score check on two different actions:

- DB query action that reads customer details from a database
- .Net method action that calculates the appropriate score

You can configure multiple actions that execute upon an event firing on a form or form control, such as a form load, button click, or selection of a table row.

For example, in a Loan Application form, you can create DB query, Web service, and Redirect actions on the Credit Check button so that when the button is clicked, the actions are executed in sequence:

- Retrieve customer details (DB query action)
- Get a credit score for the customer (Web service action)
- Take the user to the next relevant form (Redirect action)

If an action fails, a message appears, and no further actions are called. For example, if the Login fails the user is not redirected to the Work queue page.





- To reduce maintenance complexity and cost, make sure that no event fires more than 10-20 actions.
- Use clear display names for actions that reflect their purpose; you cannot change the names once created.

Action types

TotalAgility supports the following actions for a form or form control.

Action	Purpose
.NET method	Call an API for performing actions, such as creating a new job.
Add row	Add a row to a table.
Alternative extraction search	When added to a document validation form, performs an alternative extraction search in a validation activity.
Apply form variant	Apply the latest version of the form variant; the state and label text defined when creating the variant is reflected at runtime.
Apply validation	Validate the available controls on the desktop, phone, and tablet forms.
Begin condition	Begin the conditional action.
Business rule	Use a predefined business rule.
Calculation rule	Calculate a field value.
Capture client	Navigate to the next invalid field in the current document or the next invalid document or folder. If all documents and folders are valid, the activity is finished. <div data-bbox="597 1268 1451 1325" style="background-color: #e0f2f1; padding: 5px;"> The Capture client action is only available for scan forms. </div>
Change stack order	Change the stack order value or remove or move an element towards the bottom of the stack.
Clear	Clear the specified form variables and fields.
Clear selection	Clear the selections of a table or dropdown list.
Close	Close the currently opened form or pop-up window.
Composite	Include multiple actions for use on multiple controls.
Custom service	Use the Custom service action in a form control such as a button or text box.
Data object	Use the Data object action to get or set values in a data object variable to manipulate the data.
DB query	Access a database to view, insert, update, or delete records.
Delete row	Delete a row from a table in a form.
Display rule	Invoke a form's display rules and automatically change display states, based on what the user enters the form.

Action	Purpose
Else condition	Make form actions more flexible and easier to read. At runtime, all the actions within the Else condition are executed if the Begin condition is not met.
End condition	End the conditional action.
File upload	Upload a file on a form at runtime.
Fuzzy search	Find strings that closely (but not exactly) match a pattern in a "fuzzy" database, which is a single table or view exported from a relational database.  The Fuzzy search action is available only for a document validation form.
Generative AI	Make use of the Generative AI functionality within a form. At runtime, the action is executed accordingly and the output is populated correctly.
Hide action menu	Conceal a menu when a touch-enhanced Phone or Tablet form is opened on a touch-enhanced device.
JavaScript	Give access to the Document Object Model (DOM).
MFP print	Download and print the document on an MFP device.
MFP scan	Scan a document using an MFP device.  The Scan action is available by default for the MFP Scan create new job and MFP Scan take activity forms.
MFP scan settings	View and modify the scan settings on an MFP device.
Redirect	Redirect to another form or a pop-up window.
Refresh capture	Refresh the capture forms (Scan, Verification, Validation, and Document review) and capture take activity forms to prevent the job with invalid fields being completed.
Refresh page rendition	Refresh page renditions on a form and accordingly enable or disable rendition buttons at runtime.
Reset form variables	Reset the data of one or more form variables.
RESTful service	Integrate the form with external applications.
RPA	Execute the RPA Robot from within a form.
Same page	Retrieve the required data on the same page.
Set device	Switch the form factor (Desktop, Phone, or Tablet) between a desktop, phone or tablet form.
Set focus	Set the focus on a form control.
Set language from Job	Set the form language to the language of the job when the page loads.
Show message	Alert or prompt a user or request confirmation from a user.
Show action menu	Display an action menu from the list of multiple action menus for a touch-enhanced Phone or Tablet form.

Action	Purpose
Show navigation	Select the site navigation or select a menu for a touch-enhanced Phone or Tablet form.
Update control	Apply the current values of properties to the control and cause the control to reload and refresh the results list.
Update control properties	Update the properties of the control to dynamically change the display or the behavior of the control.
Update row	Update a row in a table.
Web capture	Save the pages that are scanned or uploaded using a Web Capture control.
Web service	Call a web service to perform a certain action.

SaveChanges action

The SaveChanges action persists field changes done on a form, so that they can be used by subsequent actions. This action is an automatically generated Capture action. You cannot add this action; however, you can only assign the SaveChanges action to the Capture events on a form.

Form events

This topic describes the events supported by form and controls.

Events and actions supported by advanced controls

Form Control	Events Supported	Actions Supported
Activity action button	None	None
Case health	None	None
Checklist	None	None
Create new associated job	None	None
Custom action button	None	None
Document set	None	None
Embedded page	None	None
File upload	Upload complete	All
Generative AI chat	Response returned	All
Job action button	None	None
Job list	Row selected, Refresh	All
TCM	Completed	All
Language selector	None	None
Mobile capture	<ul style="list-style-type: none"> Image captured Image processed Image uploaded 	<ul style="list-style-type: none"> ShowRejectAndAcceptButtons, All All ShowDoneButton, All

Form Control	Events Supported	Actions Supported
Mobile capture barcode	Barcode captured	All
Process viewer	None	None
Resource tree	On change	All
Summary	None	None
Thumbnail viewer	None	Display rule
Toolbar	None	None
Web capture	<ul style="list-style-type: none"> • Document save complete • Ingestion started • Ingestion completed • Document changed • Page index changed • Control undocked • Control docked 	All
Work queue	Refresh	All
Workload	Refresh	All

 When a form fails to load, an error lists the reason for failure, such as the name of the event that failed to trigger upon form load.

Events and actions supported by form and basic controls

Form/ Form controls	Event supported	Actions supported
Form	<ol style="list-style-type: none"> 1. Loaded 2. Before render 3. After render <div style="background-color: #e1f5fe; padding: 10px; margin: 10px 0;"> <p> When using these events in a form, make sure that they are fired in the following order: Loaded, Before render, After render.</p> <ul style="list-style-type: none"> • When loading forms from the cache, that is when form caching is turned on, the AfterRender and BeforeRender event types are not executed. If form caching is turned off, they are executed each time the form is loaded. </div> <p>Capture activity forms operate differently from other form types in how they render. This is due to the ThinClient control, which requires that the onLoad actions are complete before the control can fully render itself. So even though the Before render or After render events may have triggered on the containing form, the form itself may not have been rendered to the required state.</p> <p>For best practices on form loading events, see "Form loading events" in <i>Tungsten TotalAgility Best Practices Guide</i>.</p>	All
Column	None	None
Row	None	None
Cell	None	None
Label	Selection changed	None
Text box	Text changed	All
Button	Clicked	All
Table	Row selected, Row deselected	All
Drop-down list	Selection changed	All
Check box	Check changed	All
Radio button list	Radio button selection changed	All
Calendar	Date changed	All
Tab	Tab loaded	All
Hyperlink	None	None
Image	None	None
Horizontal rule	None	None

Form/ Form controls	Event supported	Actions supported
Chart	Clicked	All
List	Touch list select row	All
Tile	Clicked	All

i When a form fails to load, an error lists the reason for failure, such as the name of the event that failed to trigger upon form load.

Auto-generated actions in Capture forms and composite controls

When you generate the capture forms (Document, Folder, Scan create new job, Scan - new activity, Validation, Verification, Document review, or Device create new job), a set of predefined events and actions is associated with the form by default. For example, a validation form has a Validation form loaded event with take pending activity and validation control load batch actions. The validation control has predefined events such as Add page, Delete page, and Move page. You can add other actions such as Redirect or .Net method to a capture form or a composite control.

- i**
- If you regenerate a form, the state of the form changes. For example, if you remove any fields, they are re-added on regeneration, and it requires manual effort to return the form to the state it should be.
 - On upgrading TotalAgility, all capture forms are updated to include the new actions and the form remains in the same state as it was prior to the upgrade.
 - When you import a capture form that does not have the actions, such as a form created in a previous version, the capture form is updated to include the new actions and the form remains in the same state as it was prior to import.

Built-in Capture form actions

Many events of Capture forms (activity/document/folder) have assigned built-in (or auto-generated) Capture form actions. Some of the built-in capture actions may move focus to a different item in the batch depending on the valid state of a document/folder and some settings like Navigate to next error. But remaining actions keep the focus on the current item.

For example, if some event has the following actions, the SamePage action may take data not from the current document but from newly selected by ConfirmFieldAction.

- ConfirmFieldAction
- SamePage action (that takes field value from the current document)

The following table lists the auto-generated Capture form actions.

Actions	May move focus after completing action
Field actions on Document forms and Folder forms	
ConfirmFieldAction	Yes

Actions	May move focus after completing action
FieldForcedValidAction	Yes
VerifyField	Yes
Table fields actions on Document forms	
CaptureTableInsertRowAction	No
CaptureTableDeleteRowAction	No
CaptureTableInterpolateAction	No
CaptureTableInsertPopulatedRowAction	No
CaptureTableAddPopulatedRowAction	No
Activity form actions	
DeletePagesAction	Yes
MovePagesAction	Yes
RotatePagesAction	Yes
ChangeDocumentTypeAction	Yes
ConfirmDocumentTypeAction	Yes
OverrideDocumentProblemAction	Yes
OverrideFolderProblemAction	Yes
RestoreDocumentProblemAction	No
RestoreFolderProblemAction	No
DeleteDocumentAction	Yes
DeleteDocumentsAction	Yes
RejectDocumentsAction	No
UnrejectDocumentsAction	No
MergeDocumentAction	Yes
MergeDocumentsAction	Yes
SplitDocumentAction	Yes
MoveDocumentAction	No
CreateFolderAction	No
DeleteFolderAction	Yes
MoveFolderAction	No
SwapFrontAndBackAction	No
RejectPagesAction	No
UnrejectPagesAction	No

Events and actions supported by the Capture Client controls

The capture controls used in the capture activities expose events that correspond to the toolbar buttons, context menus, and hotkeys. Example: The OnDeletePages event is fired to delete the selected pages. Most of the events are pre-populated with actions to perform the intended operation and are available in multiple capture controls. Access to these events is based on the assigned capture permissions. You can customize these events in the TotalAgility Designer.

The following table describes the events available for capture controls, when the events are fired, and the actions they perform.

Event	Capture control	Fired	Action
Delete pages	All controls except the Verification control.	On selecting one or more pages, and selecting the Delete page action using the toolbar, page context menu, or a hotkey.	Deletes the selected pages.
Move page	All controls except the Verification control.	On moving one or more pages using a drag-and-drop operation or a hotkey.	Moves the selected pages.
Rotate page	All controls except the Verification control.	On selecting one or more pages and selecting a Rotate page action using the toolbar, page context menu, or a hotkey.	Rotates the selected pages.
Change document type	All controls except the Verification control.	On changing the document type for a document and pressing the ENTER key.	None
Create document	All controls except the Document review, Scan, and Validation controls.	Never	None
Select document	All	When the selected document changes.	None
Select folder	All	When the selected folder changes. For example, when a folder is selected in the Navigator.	None
Delete document	All controls except the Verification control.	On selecting a single document, and selecting the Delete action using the toolbar, document context menu, or a hotkey.	Deletes the selected document.
Delete documents	All controls except the Verification control.	On selecting multiple documents, and selecting the Delete action using the toolbar, document context menu, or a hotkey.	Deletes the selected documents.

Event	Capture control	Fired	Action
Reject documents	All	On selecting multiple documents and selecting the Reject action using the toolbar, document context menu, or a hotkey.	Rejects the selected documents.
Unreject documents	All	On selecting multiple documents, and selecting the Unreject action using the toolbar, document context menu, or a hotkey.	Un-rejects the selected documents.
Merge document	All controls except the Verification control.	On selecting a single document and selecting the Merge to Previous document action using the document context menu or a hotkey.	Merges the selected document with the previous documents.
Merge documents	All controls except the Verification control.	On selecting multiple documents and selecting the Merge selected documents action using the document context menu or a hotkey.	Merges the selected documents.
Scan form loaded	All	On Scan CNJ form load.	None
Scan activity form loaded	All	On Scan activity form load.	None
Scan complete	Scan control		
Validation form loaded	Validation control	On selecting the document for validation.	Validates the selected document.
Verification form loaded	Verification control	On selecting the document for verification.	Verifies the selected document.
Document review form loaded	Document review control	On selecting the document for review.	Reviews the selected document.
Split document	All controls except the Verification control.	On selecting a single page and selecting the Split document action using the page context menu or a hotkey.	Splits the document on the selected page.
Move document	All controls except the Verification control.	On selecting a single document and moving the document using the drag-and-drop operation or a hotkey.	Moves the selected document.
Create folder	All controls except the Verification control.	On selecting a folder and selecting the Create folder action using the folder context menu or a hotkey.	Creates a new child folder.

Event	Capture control	Fired	Action
Delete folder	All controls except the Verification control.	On selecting a folder and selecting the Delete folder action using the folder context menu or a hotkey.	Deletes the selected folder.
Merge folder	All controls except the Document review, Scan, and Validation controls.	Never	Not supported.
Split folder	All controls except the Document review, Scan, and Validation controls.	Never	Not supported.
Move folder	All controls except the Verification control.	On selecting a folder and moving the folder using the drag-and-drop operation.	Moves the selected folder to a new location.
Save field changes	All controls except the Verification control.	On modifying the fields of a document or folder and navigating to a different document or folder.	Saves if any fields are changed.
Capture cancel activity	All	On selecting the Cancel activity action using the toolbar or a hotkey.	Saves any changes and cancels the activity.
Capture complete activity	All	On selecting the Complete activity action using the toolbar or a hotkey.	Saves any changes and completes the activity.
Capture open activity	All controls except the Document review, Scan, Verification, and Validation controls.	Never	None
Capture complete and take next activity	All	On selecting the Complete and Take next activity action using the toolbar or a hotkey.	Saves any changes, completes the activity, and takes the next activity from the work queue.
Capture save activity	All controls except the Document review, Scan, Verification, and Validation controls.	Never	None
Swap front and back sides	All controls except the Verification control.	On selecting a duplex page and then selecting the Swap front and back sides operation using the page context menu or a hotkey.	Swaps the front and back sides of the selected duplex pages.
Process tab form load	Scan	On selecting the process that contains initialization variables.	Gets the initialization variables.

Event	Capture control	Fired	Action
Reject pages	All	On selecting one or more pages and selecting the Reject action using the toolbar, page context menu, or a hotkey.	Rejects the selected pages.
Unreject pages	All	On selecting one or more pages and selecting the Unreject action using the toolbar, page context menu, or a hotkey.	Un-rejects the selected pages.
Create new job	Scan control in a Scan Create new job form	On selecting the Create new job action using the toolbar or a hotkey.	Creates a new job.
Confirm document type	Document review control	On selecting a document and selecting the Confirm document type action using the toolbar or a hotkey.	Confirms the document type for the selected document.
Override document problem	Document review control	On selecting a document and selecting the Override problem action using the toolbar or a hotkey.	Overrides the problem for the selected document and makes the document valid in document review.
Restore document problem	Document review control	On selecting a document and selecting the Restore Problem action using the toolbar, or a hotkey.	Restores the problem for the selected document.
Override folder problem	Document review control	On selecting a folder and selecting the Restore problem action using the toolbar or a hotkey.	Overrides the problem for the selected folder and makes the folder valid in Document review.
Restore folder problem	Document review control	On selecting a folder and selecting the Restore problem action using the toolbar, or a hotkey.	Restores the folder problem.
Upload complete	Scan activity and Scan Client	When the ThinClient Capture control form sets the buttons to create a new job and complete an activity and the status text in the status bar, all uploads and mappings are completed.	Unlocks the Create a new job and Complete activity buttons.

Capture field events

Event	Fired	Action
Choice Field		

Event	Fired	Action
Selection changed	When you change a field and shift the focus from it.	None
Field confirmed	When you select a field and then select the Confirm Field action by pressing the ENTER key on the keyboard.	Confirms the selected field.
Field forced valid	When you select a field and then select the Force Field Valid action by pressing the CTRL+ENTER key.	Forces the selected field to be valid.
Combo box drop-down	When you focus on the Choice field and expand the choice list.	None
Text Field		
Text changed	When you change a field and shift the focus from it.	None
Field confirmed	When you select a field and then select the Confirm Field action by pressing the ENTER key.	Confirms the selected field.
Field forced valid	When you select a field and then select the Force Field Valid action by pressing the CTRL+ENTER key.	Forces the selected field to be valid.
Boolean		
Check changed	When you change a field and shift the focus from it.	None
On field confirmed	When you select a field and select the Confirm Field action by pressing the ENTER key.	Confirms the selected field
Field forced valid	When you select a field and then select the Force Field Valid action using the toolbar or the CTRL +ENTER key.	Forces the selected field to be valid.
Table		
Table cell confirmed	When you select the table cell and select the Confirm Field action by pressing the ENTER key.	Confirms the selected table cell.
Table cell forced valid	When you select a field and select the Force Field Valid action using the toolbar or the CTRL+ENTER key.	Forces the selected table cell to be valid.
Table forced valid	When you select a table and select the Force Field Valid action using the toolbar or the CTRL+ENTER key.	Forces the selected table to be valid.
Table row added	When you select the Add Row action from a table toolbar.	Adds a new last row to the table.

Event	Fired	Action
Table row inserted	When you select an Insert Row action from a table toolbar.	Inserts a row in the table before the currently selected cell or row. If there is no selected cell or row, the new row is added to the end of the table.
Table row deleted	When you select a Table Row select the Delete Row action from a table toolbar.	Deletes the selected table rows.
Interpolate table	When you select a Table Row and select the interpolate table action from a table toolbar.	Performs interpolation using the selected row as the template for finding additional rows.
Table cell combo box drop down	When you focus the Table cell in a choice column and then expand the choice list.	None
Table populated row inserted	When you add a row to a table in a form using the Add Row action.	Inserts a row populated with data into the table.
Table populated rows inserted	When you add a row to a table in a form using the Add Row action.	Executes a .NET action to insert multiple rows into the table.
Row selected	When you select a table row or any cell in that row.	None
Row deselected	When you deselect a table row or any cell in that row.	None

Events and actions supported by an MFP form

The following tables state the events and actions supported for basic and advanced controls on MFP forms.

Events and actions supported for basic controls

Form/ Form controls	Events supported	Actions supported
MFP form	Loaded MFP start button pressed MFP pause button pressed MFP clear button pressed MFP tips button pressed MFP scan complete MFP scan failed	All
Label	None	None
TextBox	Text changed	All
Button	Tap	All
Table	Row selected Row deselected	All

Form/ Form controls	Events supported	Actions supported
Drop-down list	Selection changed	All
Check box	Check changed	All
Image	None	None
Hyperlink	None	None
Tab	Tab loaded	All
Horizontal rule	None	None
Calendar	Date changed	All
Radio button	Radio button selection changed	All
Cells	None	None
List	List select row Menu button1 click Menu button2 click Swipe button1 click Swipe button2 click	All

Events and actions supported for advanced controls

Form/ Form controls	Events supported	Actions supported
Embedded page	None	All
File upload	None	All
Mobile capture	On image captured On image processed On image uploaded	All
Mobile barcode capture	On barcode captured	All

Events and actions supported by the tablet and phone forms

The following tables state the events and actions supported for basic and advanced controls on a Tablet and Phone forms.

Events and actions supported for basic controls

Form/ Form controls	Events supported	Actions supported
Phone form and Tablet form	Loaded Before render After render	All
Label	None	None
TextBox	Text changed	All
Button	Tap	All

Form/ Form controls	Events supported	Actions supported
Table	Row selected Row deselected	All
Drop-down list	Selection changed	All
Check box	Check changed	All
Image	None	None
Hyperlink	None	None
Tab	Tab loaded	All
Horizontal rule	None	None
Chart	Tap	All
Calendar	Date changed	All
Radio button	Radio button selection changed	All
Cells	None	None
List	Touch list select row Menu button1 click Menu button2 click Swipe button1 click Swipe button2 click Item touch start Item touch move Item touch end	All

Events and actions supported for advanced controls

Form/ Form controls	Events supported	Actions supported
Embedded page	None	All
File upload	Upload complete	All
Mobile capture	Image captured Image processed Image uploaded	All
Mobile bar code capture	Barcode captured	All

Form variables

Form variables hold data at the form level for use wherever required within the form, such as within actions. This eliminates the need to create hidden fields on the form to hold data. Once created, use form variables in the same way that you use fields, and global variables.

Form variable types

TotalAgility supports the form variables of type Array, Boolean, Byte, Date, Decimal, Numeric, Data object, and String.

Deploy forms

Once you finish designing your form, save or release it.

- Saving a form saves the changes to the form with a minor version.
- Releasing a form makes the form ready for production and viewable at runtime, updating it to a major version.

Once a form is released, use the following URL to access the form at runtime:

```
http://[servername]/TotalAgility/Forms/<formname>.form
```

If a site is used, use the following URL:

```
http://[servername]/TotalAgility/Forms/<sitename>/<formname>.form
```

Form debugging

Debugging allows testing and debugging of forms at runtime. Debugging increases efficiency as issues can be identified much quicker when developing a solution.

In a debug mode, you can do the following with a form:

- Automation Request
- Set breakpoints
- View and edit variable values
- Step through the actions, or run to the next breakpoint
- Expand Server-side actions to show its inputs and output

 The Client-side actions cannot be expanded to show any details.

Associate a form with an activity

A form can be associated with an activity through the Associated file path property on an activity.

This property is populated automatically when a Take activity form is generated, or can be populated manually.

When users take an activity, they are redirected to the form specified in the Associated file path property. If the property is blank, the users are redirected to the generic Take activity form.

Sites

Use the site to define the default styling and navigation to get the look and feel of your solutions to your requirements.

You can use the same forms in different contexts to get different looks and feel. You can create, modify, and delete a site, and specify the supported language to use for your site.

Within the same site, you can configure settings to use for your Desktop, Tablet, and Phone forms. This means that you could have different styling for the same form depending on the settings, and the device on which you are viewing the form. For example, if the form is being viewed on a desktop, the form will be displayed based on the desktop settings (unless a specific header form or navigation has been selected in the form).

The same form can be used in multiple sites, but the look and feel changes based on the theme, header, and menus associated with the site.

Themes

A theme is a set of design elements and color schemes that define the visual layout of forms. Themes provide a consistent, professional look and feel to your forms.

Once a theme is associated with a site, it is automatically applied to all existing forms within the site and any new forms added to the site.

When you select a predefined style for your theme, the new look is applied to all forms using that theme.

You can also configure themes for form controls. Any settings for the controls at the form level override the site-level settings in the following order: control-specific styles, font/background overrides, and style sheet used in a theme.

Global variables

You can define variables as global variables for use across several forms.

For example, if you need to interact with the TotalAgility database, you can create a global variable with DSN=TotalAgility, as its value. The same variable can be used in different forms to interact with the TotalAgility database, and its value can be managed in one place.

You can optionally provide localization for global variables.

TotalAgility provides the following out-of-the-box global variables with the Workspace package and they are used across Workspace forms:

- Case reference
- Job identifier
- Process identifier

- Process version
- Resource ID of the currently logged-on user
- Name of the currently logged-on user
- Session ID of the currently logged-on user

Security tokens

Security tokens associated with security roles and resources enable form designers to control the security of information by restricting access to relevant areas of an application and hiding information that users are not authorized to see.

Site designers face the challenge of ensuring that information remains secure against threats from both inside and outside an organization. Security breaches can result in the loss of business opportunities, expensive lawsuits, and even bankruptcy. Therefore, it is imperative that you safeguard the integrity of your data against any violations.

For example, access to a section containing salary details could be restricted to the Finance team. This protects confidential information from unauthorized access.

Within the Workspace, administrators can create security roles and associate tokens and users with the security roles, thus delivering flexibility in how security is managed.

For more information on security, see "Form security" in *Tungsten TotalAgility Best Practices Guide*.

Navigations

Use the navigation to define how users navigate a site, to go from one form to another.

You can add multilevel navigation capabilities to your site. The navigation menu acts as a roadmap with clearly marked destinations and suggested routes that direct you from one form to another.

You can add customizable vertical and horizontal navigation bars to your site and allow or deny access to menu items.

 A vertical navigation bar can only be positioned at the left side of forms.

The navigation menu is defined at the global level; once applied to a site, it is available for all forms within that site. .

When you change a navigation item, such as a top-level menu option or menu title, the changes are automatically applied across all forms using the defined navigation layout.

You can specify whether to include horizontal and vertical navigation menus on individual forms, as some forms, such as login forms and pop-up windows do not require them.

The style for a menu depends on the menu style configured in the theme.

Customer assets

You can upload "assets" such as images, style sheets, document templates, custom pages and .NET assemblies without having to keep files on the disk and access them using a public URL.

The assets are stored within TotalAgility and as such can be used during form and process design.

Form variants

Create multiple variants of a form to dynamically hide or disable controls and columns or change the label text to display at runtime for all form types.

You can create one generic form and present it differently depending on the variant in use.

 The following forms do not support form variants: Scan create new job, Validation, Verification, Document review, Scan, Document, Folder, Device create new job, MFP, MFP activity, MFP work queue and MFP Scan create new job.

Chapter 5

Workspace

Tungsten TotalAgility Workspace is a web application that allows users to interact with activity lists, cases and processes; manage work and resources; and administer other data elements.

You can customize or extend the TotalAgility Workspace according to your business requirements.

Create work

Create jobs, cases and fragments

Within the Workspace a generic form is available to allow creation of a job, case or fragment. This form also displays any initialization parameters defined on the selected process.

For a case or case fragment, the case reference must be supplied.

As an alternative, a form specific to the process can be created in the TotalAgility Designer (User Interface > Forms > Generate). This allows you to provide a tailored user interface for creating jobs for a particular process.

Job or case properties

When a job has been created it is possible to see the properties of this job. The properties form displays all artifacts related to the job in question. This includes the general properties, milestones, states, variables, notes, events, roles, and documents.

Find jobs or cases

You can search for jobs based on criteria, such as Priority, Due Date and Creator using the Show Query option in Workspace.

Manage work

Work queues

You can view the list of tasks assigned to you and all tasks assigned to the group (team) to which you belong. This helps you focus on the tasks or projects that require your attention, especially if you work in multiple areas at one time.

Queries panel

See [Queries](#).

Take and complete activities

Activities can be taken and completed by a resource to which the activity has been assigned directly to them or to a group that they are a member of. By taking an activity, the output parameter values can be updated and applied when the activity is completed. The workflow proceeds to the next activity in the process.

Delegate work

To handle sick time or vacations, use the Delegation feature to allocate new activities from one resource to another, for a specified time period.

Delegating an activity differs from reassigning an activity. When delegating, the activities appear on the work queue for both resources.

Reassign work

To change the assignment of an activity from one resource to another, you can reassign the activity. This results in the activity no longer appearing on the original resource's work queue.

Manual work allocation

You can manually allocate work in two ways:

- **Activity Centric:** Based on the importance of an activity, select the best resource to work on it.
- **Resource Centric:** Based on the importance of a resource and to optimize resource utilization, select the best activity to allocate to a resource.

Reset taken activities

This screen allows an administrator to reset activities taken by other resources to pending.

When an activity is taken by a resource but not completed, then the activity remains taken until one of the following actions occurs:

- The user cancels, saves or completes the activity.
- The activity is reset to pending.
- The user logs out of all active sessions.
- The user logs in (and there are no other active sessions).
- Session timeout occurs.

Modify live jobs and activities

In Workspace, you can view and change the properties of jobs that are Live, Suspended, or On Hold, which gives you the flexibility to respond to process changes as they happen.

You can also modify job activities that are in a pending state, members of floating roles assigned to a job, and the static resources, roles and groups assigned to each live activity in a job.

To modify jobs, you must have the correct access privileges.

i You can only modify the activity members when workflow rules are not used for an activity at design time.

Place jobs on hold

Placing a job on hold delays processing for a specified period of time (up to 52 weeks). When a job is placed on hold, it means no activities are available on any work queues and no event processing is done for the specified hold time. When the hold time is completed, the job automatically moves to the active status and the activities become pending. Alternatively, you can Activate the job and therefore remove it from the hold status.

For example, you may want to place a job on hold if someone is off sick or on leave for a couple of weeks and you would rather place that job on hold than re-assign or delegate it.

Business calendar

The global business calendar enables you to set working or non-working days and working hours across all resources. Each resource can also have a personal calendar derived from the global calendar.

When the business calendar is turned on, these working or non-working days are taken into account when calculating due dates, SLAs and more within the system.

Manage your system

Logged on users

You can view a list of users currently logged on to the TotalAgility Workspace and log off selected users.

Audit log

Audit Logs are useful for tracking information pertaining to and resulting from the execution of a business process or system function. This information helps you pinpoint and analyze the cause of a change, who made the change, and when the change was made. You can view all audit logs or filter them by date range and audit log type.

Upgrade jobs

You can upgrade live jobs that are not complete or terminated to the latest released version of the job process map. This feature lets an organization make changes to live jobs without terminating or restarting them. The changes go into effect immediately.

Upgrading a job adds new items, such as variables, floating roles, work type fields and milestones to the selected jobs. The upgrade does not overwrite or delete any existing job data.

Remove finished jobs

You can remove all finished jobs or those within the specified time range, allowing database space to be freed.

Performance statistics

You can view performance statistics for a process and its activities over a specified time period or number of jobs. These statistics can be used to determine how cost- or time-effective a process or an activity is and if you need to make adjustments to improve it. As a result of this analysis, you can change some key operational items within the process and its activities.

View the following performance statistics for a process:

- A text description of the range, which is either a timeframe or number.
- A count of jobs that are being evaluated based on the selected range. For example, if you select last month as the date range, the statistics display the number of jobs covered during last month. However, if you select a number of jobs, for example, the last 1000, but only 50 jobs are available, the statistics display 50 as the jobs analyzed.
- The percentage and number of jobs completed within the specified duration.
- The percentage and number of jobs completed within budget.
- The average duration of jobs.
- The average cost of jobs.

 The monitor service must be running to correctly record and display cost overruns when you view process performance.

Management Console

The Management Console provides visibility into the functioning of the entire deployment. It provides insight into what is happening now and what has happened recently so that areas of concern can be addressed, or the system can be optimized for future performance. Administrators can therefore identify issues quickly and efficiently or intercept the automation agents to optimize and adjust how they are processing work.

The Management Console option in TotalAgility Workspace is only available for TotalAgility on-premise installations. It is not available for on-premise multi-tenant and Azure environments.

Chapter 6

Resources in TotalAgility

A resource is a person or a group of people who work in an organization. In TotalAgility, you can create individual workers and groups, and add external resources to your system. You can have subgroups within groups. When a task is assigned to a group, any resource from that group (or its subgroups) can perform the task. For example, a financial company has three worker groups: Financial Analysts, Business Analysts, and Cost Analysts. Each group has expert resources. If you add the Business Analysts group and Cost Analysts group to the Financial Analysts group, any task assigned to the Financial Analysts group is available to the Business Analysts and Cost Analysts groups.

You must define resources, which are integral to setting up and creating business processes, before creating process maps.

Individual resource

An individual resource in TotalAgility is a person who is responsible for creating or completing work or performing administrative or supervisory tasks. Each worker must have a unique identity that allows authentication within the system.

Group resources

A group is a collection of one or more individuals. A group can contain other groups. An individual resource can belong to many groups.

When an activity is assigned to a group, it can be taken by any individual in that group or subgroups within that group.

TotalAgility provides the following default groups:

- **Administrators:** The members of this group have full control to the system.
- **Designers:** The members of this group have access to TotalAgility Designer and Transformation Designer.
- **Device Users:** The members of this group have access to MFP devices.
- **Everyone:** A special group within TotalAgility. All individual resources created in TotalAgility through resource configuration are automatically added to this group.
- **Insight Admin:** The members of this group can perform administrative tasks on Insight from TotalAgility.
- **Insight Users:** The members of this group can use Insight from TotalAgility.

- **Process Intelligence**

 The installation user is automatically added to Administrator, Designers, Device Users and Everyone groups.

External resources

In some instances, you may add an external resource who joins the organization for a limited period to complete specialized activities. For example, you need an external solicitor on a temporary basis to verify the receipt of documentation.

External resources have limited access: they can only view their work queue, and take and complete the relevant activities listed on their work queue.

External resources can be assigned work directly or by means of role membership. They do not belong to the Everyone group.

Email address

You can assign an email address to each resource. A system setting is available to force uniqueness of email addresses.

Password

You can assign a password to a worker or external resource. The password is stored as an encrypted value.

Personas

Use personas to divide your target audience into individual groups of people. Each persona is distinct, based on individual interests and needs.

When you associate a resource with a persona, the resource is directed to a target landing page that offers content specific to that persona.

Resource extensions

You can extend information held in TotalAgility for all workers or groups by defining metadata at the system level. When you configure a worker or group, you can manage the values for that supplementary information, such as, resource address, date of birth, job title and more.

Working group

A resource can belong to many groups, but you can assign a working group to a resource to keep the focus on all activities related to that group.

Supervisors

A resource with managerial rights can become the supervisor for other resources, or a group of resources.

You can create a hierarchy of supervisors by assigning a managerial level 1 through 10, with 1 being the highest.

Security levels

Use security levels to control which resources can work on which activities. Security levels range from 1 to 10, with 1 being the highest level of security. The default security level of a resource is 10.

You can assign a security level to an activity, and only resources with a security level equal to or greater than that level can perform the activity.

Skill levels

Use skill levels to assign work to resources where the work must be performed by someone with a specific skill level. Skill levels range from 1 to 10, with 1 being the highest skill level. The default skill level of a resource is 10.

You can assign a skill level to an activity, and only resources with a skill level equal to or greater than that level can perform the activity.

Variable and fixed costs

A fixed cost is a one-off cost regardless of the time spent, whereas a variable cost has a rate per time period calculated based on the time spent. For example, a service engineer has a call-out charge of \$50 (a fixed cost) and charges an additional \$10 per hour (variable cost). Three hours work would cost \$80.

Variable and fixed costs can be accumulated and recorded based on the time spent working by that resource.

Variable costs can use days, hours, minutes and/or seconds as the unit of measure.

Active period

An active period is the duration for which a resource is active. You can assign start or end dates to each worker or external resource in TotalAgility, which grant access to the system without having to remove the resource.

An active user is one with no start date or a start date equal to or less than current date; also, an active user has no end date or an end date greater than current date. Inactive users cannot logon to TotalAgility.

Defining the active period is particularly useful for external users, as they may only be active for the duration of a case or for short periods of time. The active period also indicates when a worker started and or left the company.

Working category

A resource has access to many categories. Setting the working category allows the user to focus on all activities related to that category. The working category appears when a resource performs an action, such as opening a map or creating a job on a process in the TotalAgility Workspace or Designer.

Active Directory Synchronization

See [System processes](#).

Chapter 7

System data

You can reuse System data, such as server variables, lookups, entities, work types, document templates, and checklist templates, across your processes and forms.

Server variables

Server variables are used to hold values that are global in the system; any business processes, cases, or case fragments can use them.

Server variables can only have one value at any given time. For example, if the location of company templates is kept in a server variable and the location changes, you can change the variable value and the change would be reflected across all processes that use the variable. It is also possible to secure the values of these variables.

For example, you may not wish anyone to see a connection string because it contains secure information. If the location is defined at the process map level, as a process variable, the location would need to be changed on all processes individually.

TotalAgility provides some [predefined server variables](#).

Predefined server variables

The following table describes the system server variables.

Name	Type	Description
AD_CHASE_REFERRAL	Bool	If this variable is set to True, then even a resource existing elsewhere in the AD structure but is a member of the group you are syncing, is imported. (Default: False) The import only works if Chase Referral is also enabled within AD itself. The AD_CHASE_REFERRAL is useful when importing cross-domain resources.

Name	Type	Description
AD_DEACTIVATE_USER	Bool	<p>Active Directory synchronization tries to delete users from TotalAgility when corresponding users are deleted from the active directory. If the deletion of the user fails for any reason, such as the user is currently logged in or assigned to a live activity, the AD_DEACTIVATE_USER setting controls what happens next.</p> <ul style="list-style-type: none"> • If False (default), the Active Directory synchronization process logs an error attempting to delete the user. The process is then routed to a review activity (along with any other synchronization errors) for an administrator to review. The administrator may re-process any failures by taking corrective action such as forcibly logging out the target user. • If True, the user that could not be deleted is deactivated with no further access to the TotalAgility platform. In this case, the Active Directory synchronization process does not record an error or route it for review.
AD_EMAIL_ADMINISTRATOR	String	Email address of the user or group who is notified of critical errors, such as "Admin@sampleemail.com".
AD_EMAIL_CONTENT_CRITICAL	String	Content of the critical error in the email, such as "There has been a critical error syncing with Active Directory. Error returned was:".
AD_EMAIL_CONTENT_ERRORS	String	Content of the soft errors (not critical) in the email, such as, "Some Errors have occurred while syncing with Active Directory, please visit the link below to view these:"
AD_EMAIL_SUBJECT_CRITICAL	String	Subject of the critical error in the email, such as "Critical Error Syncing Active Directory".
AD_EMAIL_SUBJECT_ERRORS	String	Subject of the soft errors in the email, such as, "There were errors during the sync with Active Directory."
AD_LAST_USNCHANGED	String	<p>Every change within Active Directory gets a unique incrementing change number (USN). This number is stored in TotalAgility in the AD_LAST_USNCHANGED server variable. This variable is used by the Active Directory Synchronization activity and a value of 0 ensures that full synchronization of all data is complete.</p> <p>The latest USN is then updated to the AD_LAST_USNCHANGED server variable. Subsequent synchronization only checks for changes since the last USN number. This is the routine synchronization for the system. For full synchronization, you can manually reset the AD_LAST_USNCHANGED server variable to 0 and execute a new job on the SYSTEM Active Directory Synchronization map.</p>
AD_PASSWORD	String	Password for the account to connect to your Active Directory server.
AD_PORT	Long	The port used for LDAP or LDAPS protocol. If the port is not specified, the default port 389 or 636 is used for the respective LDAP or LDAPS.

Name	Type	Description
AD_SECURITY_LEVEL	Short	The TotalAgility security level of the TotalAgility defined resource required to complete the activity. If the security level is 10 (default), TotalAgility resources with any security level can complete the activity. If the security level is one, only TotalAgility resources with the highest level of security can complete the activity.
AD_SERVERNAME	String	Machine name of your Active Directory server. TotalAgility only uses Server Name and OU combinations in the AD_SERVERNAME variable.
AD_SERVERNAME_CN	String	A specific group level where the AD is synchronized. This means that only those resources which are members of this group are synchronized. These variable names are case sensitive; if you do not enter the values the same as they are created within Active Directory, the job suspends and reports an error such as "Parameter is Incorrect" or "Parameter is not Found".
AD_USE_SECURED_CONNECTION	Bool	Indicates whether SSL can be used over LDAP when synchronizing TotalAgility with the Active Directory server. (Default: False)
AD_USERNAME	String	A valid Active Directory account to connect to your Active Directory server. ad_username must have appropriate user rights on the items being synchronized in Active Directory to extract the relevant information from Active Directory. The username with more than 56 characters is truncated.
LIMITED_USER_SESSION_ID	System	LIMITED_USER_SESSION_ID is like the System session ID but just for limited users. You set this at runtime as you do for the System session ID system server variable.
SKILL_LEVEL_SETTINGS	Short	The skill level of the TotalAgility-defined resource required to take and complete the activity.
SPP_SMTP_SERVER	String	Email server (SMTP) name used to send emails. (Default: localhost)
SPP_SYSTEM_SESSION_ID	System	A unique system session ID for each installation of TotalAgility that allows execution of any secure SDK call. It is used by all system processes to make a call to SDK API.
SYSTEM_EMAIL_FROM	String	Holds a valid email address for the system account sending the mail to the administrator.
USE_DESIGNTIME_RESOURCES	Bool	Indicates whether to use the design time resources. It is used by the SYSTEM Perform Auto Work Allocation system map to perform work allocation.

Regular expressions

Regular expressions are used in text format validation form fields, document fields, and password formats.

TotalAgility provides several predefined regular expressions. However, you can define custom regular expressions to use in forms and validators.

Regular expressions are used to recognize patterns with textual data. They evaluate text data and match an expression with the text in the document. In TotalAgility, regular expressions are used in format locators, validation methods, and formatters, to identify and normalize items on a document.

Regular expressions describe data in an abstract way, and some common examples are listed in the following table.

Format	Description	Example	Matches	Does Not Match
C	One character	a	a	b,A
.(period)	Any character	b.g	bug, bag, big, bbg	bg, baag
\d	Any single digit	a\d	a5, a8, a0	aA, ab, a
c1c2c3	One character out of a set	[abc]	a,b,c	1, 2, d, D, A, ab, bc
[c1-cn]	One character out of a range	[a-z]	b,g,x	1, 2, D, A
? (question mark)	The previous term is optional	x\d?	x, x7, x1	xx, xq
+ (plus sign)	The previous term can be repeated one or more times	\d+	4, 2323, 100	A112, 2b, X
* (asterisk)	The previous term can be repeated zero or more times	x\d*	x6, x, x100	100x, xx
{n}	The previous term can be repeated exactly n times	y{3}	yyy	yy, yyyy
{m, n}	The previous term can be repeated between m and n times	\d{5,9}	12345, 999999999	1234, 99999999999
\	Escape special characters	\\$ \\ \- \? \.	\$ \ - ?	!%
()	Group characters	a(\\$\\$)?b	a\$\$b, ab	a\$b, a\$\$
(e1 e2)	Choice	(abc ABC)	abc, ABC	aBC, AbC

Format	Description	Example	Matches	Does Not Match
\n	Back reference (nth item matched in round brackets need to be matched again)	(\d)\1	1x1,2x2,3x3,4x4...	1x2,6x7...

You can find many third-party resources on the internet about regular expressions. In many cases, however, extensive knowledge of regular expressions is not needed because TotalAgility provides a set of commonly used and predefined templates.

If any of your documents have special ASCII characters that you want to locate and extract, you can do so using regular expression codes for ASCII characters. The following table shows the conversion requirements.

ASCII Hex	Special Character	Regular Expression Code
21	!	\x21
22	"	\x22
23	#	\x23
24	\$	\x24
25	%	\x25
26	&	\x26
27	'	\x27
28	(\x28
29)	\x29
2A	*	\x2A
2B	+	\x2B
5E	^	\x5E
A7	§	\xA7

For example, a single entry of \x2A can be used to match a single character. In this case, an asterisk (*). In addition, you can use these characters as a range. For example, [\x21-\x29] can locate any of the following characters; !"#%&'().

Lookups

A lookup is a list of static data items defined at the server level that can be used across all forms or processes.

Use lookups to display content in different languages and reuse a lookup within entities across processes or forms.

By default, the system creates a lookup in the language of your system. You can create or translate a lookup in a different language.

 The language selected for a lookup at design time must also be available at the site level; otherwise, the lookup is not displayed at runtime.

Document templates

A document template is used to create a document.

You can upload document templates to TotalAgility and use these templates in a Document creation activity to create a document.

 TotalAgility only supports Microsoft Word templates, .dotx and .dotm.

Currency codes

Currency codes help in formatting text boxes within forms.

You can associate a currency code with a text box to mask the symbol and format in which the data is entered at runtime. This ensures the mask for data entry corresponds to the browser locale. For example, the format to enter Euros in Germany is different from entering the value when in Ireland.

The following currency codes are available out-of-the-box:

- Euro €
- Pound Sterling £
- Dollar \$

Error codes

Error codes are text codes that can be localized and used in parts of the system as needed.

For example, you can save errors encountered during validation as error codes and later localize them. You can use these error codes in Expression nodes in business rules and configure them as outputs.

Checklist templates

Use a checklist template to group commonly used items for reuse. For example, group Name, Address, Telephone Number, and Email ID into a PersonalDetails checklist template and use the template to create employee records, customer details, or patient records.

In this example, the Customer Details and Employee Details templates have the following common checklist items: Name, Address, Email, and Phone.

- For the Employee Details template, if you create one column, such as Complete, one option appears for each checklist item in the template at runtime.

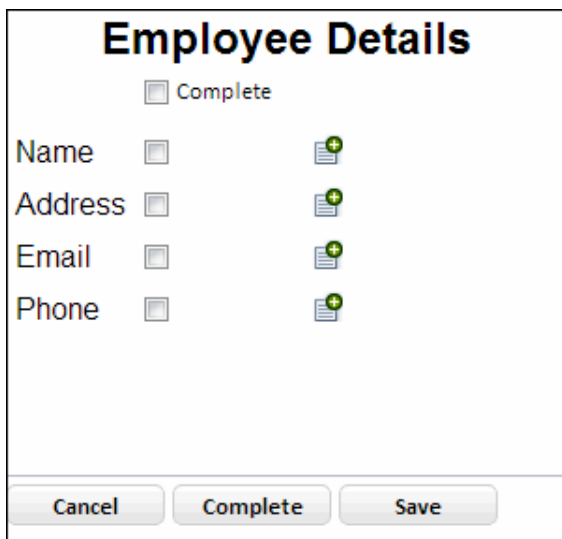

The screenshot shows a dialog box titled "Employee Details". At the top, there is a checkbox labeled "Complete". Below this, there are four rows of checklist items: "Name", "Address", "Email", and "Phone". Each item has a checkbox and a document icon with a green plus sign. At the bottom of the dialog, there are three buttons: "Cancel", "Complete", and "Save".

- For the Customer Details template, if you create two columns, such as Yes and No, two options appear for each checklist item in the template at runtime.

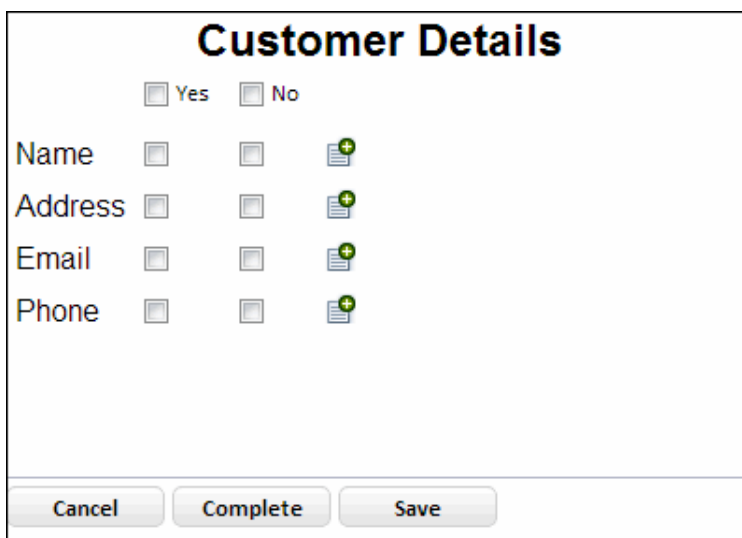

The screenshot shows a dialog box titled "Customer Details". At the top, there are two checkboxes labeled "Yes" and "No". Below this, there are four rows of checklist items: "Name", "Address", "Email", and "Phone". Each item has two checkboxes and a document icon with a green plus sign. At the bottom of the dialog, there are three buttons: "Cancel", "Complete", and "Save".

Checklist items

Checklists can guide inexperienced users through each step in a process.

Use the output from checklists to display the stage of the job. For example, a customer applies for a credit card online and provides a name, address, employer name, and yearly income. The bank verifies the details and determines the credit limit. The bank can use a verification checklist to track the process as shown in the example map:

- **Check Customer Details:** In this activity, the checklist is an output variable, and the Bank Clerk checks the details and completes the checklist. TotalAgility sets the state of the job as ready for review and the job passes to the Review Customer Details activity.
- **Review Customer Details:** In this activity, the checklist is set as both input and output variables. At this stage, the checklist appears in two columns; the first column completed by the Bank Clerk is read-only. The second column is editable and is completed by the Bank Manager who reviews the details.
- **Fix Credit Limit:** After the Bank Manager completes the checklist if the details are approved, the job passes to this activity.
- **Notify Customer:** If the details are not correct, the job passes to this activity, and the credit card is not issued.
- **Issue Credit Card:** In this activity, the bank issues the credit card.

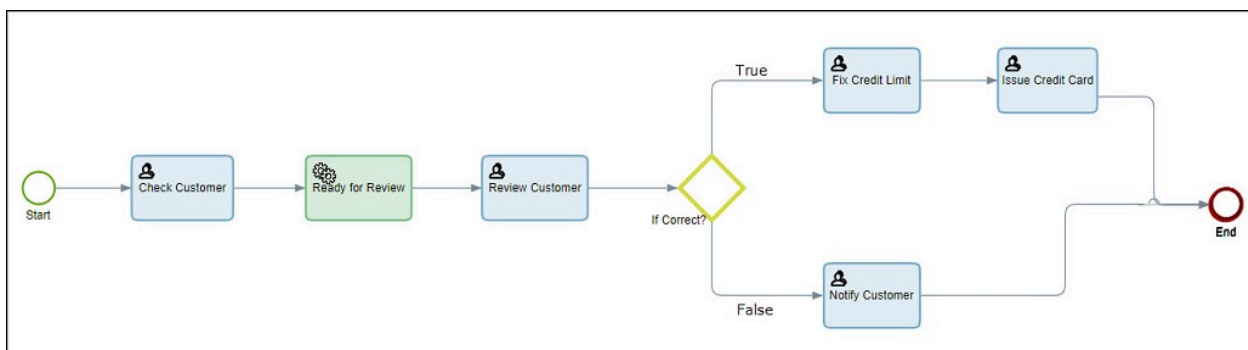

Create a checklist.

Use the Ready for review node to enable a checklist for review.

A checklist has three states that determine whether the checklist is editable and whether the checklist includes a second column of data:

- **Read only:** The checklist is only set as an input to an activity.
- **Read/write:** The editable checklist is an output of an activity.
- **Review:** A Ready for review node marks the checklist for review. The first column in the checklist is read-only. The second column is editable.

At runtime, you can enter comments against any of the responses defined for the checklist and can select one response to apply against all questions at once.

Before you progress an activity, you can query a checklist to determine if all items are complete.

Work types

Work types help in controlling the appearance and behavior of fields on a work queue form.

The following image displays the work queue of a user, where the tasks can be taken and completed.

Work Queue						
+ [Icons] < Refresh Edit Query						
Activity Name	Customer Name	Account Number	Process	Priority	Due Date	
Confirm Details	Bob Smith	3435665X	Student Loan Application	1	08/07/2019 09:13:22	
Confirm Details	Jane Cameron	34463665S	Student Loan Application	1	08/07/2019 09:13:38	

By default, process maps use a standard work type, which appears on a work queue window and consists of the following standard fields for a job or task:

- Take activity button
- Name
- Description
- Due date
- Priority
- Job ID
- Version
- Process
- Resource
- Job SLA status
- Job state
- Activity SLA status

You can create work types under any category for which you have "Full control" or "Read write" access. You can create a copy of a work type, associate the work type with a process map, and view all the process maps associated with a work type.

Work types are synchronized to the process maps with which they are associated. When you modify a work type, the changes apply to all maps that use it.

You can customize a work queue by creating work types with custom fields. Customizing a work type reduces overall development time because the programmer can render the work type on a web page or form.

Each custom work type can contain up to 30 additional fields (variable names), which can display variable values obtained from within or from an external system, such as SUPPLIER_NAME, DOC_ID, DOCUMENT_NAME, and INVOICE_NO.

 At runtime, only 100 characters are stored as the value of the field.

The GetWorkQueue2 API returns the custom fields in the work type, and lets you sort, prioritize, and filter work queue tasks.

Tags

A tag is a free text that helps you provide information about an item and makes the item easier to find.

Any tags created under System data are available for use in processes, skins, business rules, forms, form templates, extraction groups, classification groups, folder types, and data models. You can also create a tag directly for an item.

Data models

A data model is a user-defined data structure that represents a collection of data.

Data models simplify integration with REST APIs and reduce database storage space. A data model is used to group data. The data held within the structure can be used in processes and forms using the [data object variable](#).

You can define global and local data models.

A global model is available to all processes and forms, but a local model is available only to the form or process it is defined for. A local data model is useful for one-off integrations when you do not have to reuse the data model.

You can also create a global or local data model using a sample JSON. On adding a JSON file, the JSON format is parsed, and a tree structure is created. The field names in the data model match that of the JSON, and the field types are implied from the JSON sample. Any ambiguous field types are set to string. You can edit the data model by changing field types or deleting the fields that you do not want. You can create a data model for simple JSON strings, with strings having nested objects, multiple objects, and with an array of data.

You can generate the global data models using the Generative AI functionality.

Chapter 8

Capture

Using TotalAgility, you can drastically reduce your organization's labor-intensive processes by capturing all types of content for automatic classification, extraction, validation, and delivery into applications, processes, and repositories.

Capture information at any point in the business process, and without human intervention, extract, separate, classify, validate, and perfect information. For example, after the loan application process starts, a financial institution may request documents, such as Proof of Income and Credit Reports. The information can be captured anytime from any source, including from mobile or tablet devices, and ingested into the loan approval process.

Classify documents; define scanner or device settings for reuse; separate and automatically place documents in folders during capture.

 Business documents are usually smaller than A3, larger formats are typically used for blueprints and large graphics. TotalAgility does not support images of paper size larger than A3.

You can export images (or both images and text that has been automatically extracted from the images) to a PDF or other file format, define resolution and quality, and more. You can identify text and graphics, convert them to HTML and XML file formats, and ensure interpretation by assistive software for the visually impaired.

You can also create capture-related items, such as extraction groups, document variants, field formatters, and field validators.

Extraction groups

An extraction group is a set of one or more document types that helps to classify and process the documents.

An extraction group contains a default document type called `RootDocumentType`. All document types are created within the default document type.

Classification groups

A classification group is a set of extraction groups. A classification group helps in classifying documents.

You can include the same extraction group in multiple classification groups. You can tag a classification group so that you can add some text to describe what the classification group is about.

Folders

A folder is a group of one or more folder types that help classify and process documents. For example, a Human Resources folder may include folder types for Recruitment, Skill Set, Salary Revision, and so on.

By default, TotalAgility contains a root folder that includes the following system-defined fields: Instance ID, Type, and No. of documents. You can create a hierarchy of folders within the root folder. Each folder can include a child folder. All custom folders automatically inherit fields from the default folder.

Document and activity variants

You can create variants for a document type and activity variants for a document variant.

If you set the fields as ignored in a Document or Activity variant, the fields exist on the form but are hidden. Use a variant only for fields that do not have additional condition rules around usage.

Document variants

Create variants against a document type and specify the fields to ignore. Thus, you can have one generic document and present it differently depending on the variant in use.

Benefits of document variant include:

- **Flexibility:** Variants allow you to have a flexible and scalable approach. Using variants, you can accommodate different document types without having to design and maintain multiple forms.
- **Simplified maintenance:** Instead of managing several form templates, you only need to maintain one generic form. Then update or change it centrally, reducing the effort, and ensuring consistency across all document variants.
- **Efficient data capture:** Users can focus on relevant fields for each document type, minimizing errors and improving data capture accuracy by hiding unnecessary fields on the user interface.

The Document variant option is only available when you generate a Scan create new job or Scan - Activity form. Variants are not available on the File upload or any other Capture controls; documents captured this way can be updated to apply a variant using the SDK.

Use case: Create variants for document types

In this example, the master document includes example fields for purchase orders, invoices, and receipts. Each document variant represents a specific type of document and displays the relevant fields while hiding the unnecessary ones.

Document Variant	Fields displayed	Fields hidden	Purpose
Invoice document variant	<ul style="list-style-type: none"> • Invoice number • Billing address • Item details • Total amount • Due date 	<ul style="list-style-type: none"> • Purchase order number • Shipping address • Receipt number • Payment details 	This variant focuses on the fields required for processing invoices. Fields specific to purchase orders and receipts are hidden since they do not apply to invoices.
Purchase order document variant	<ul style="list-style-type: none"> • Purchase order number • Billing address • Item details • Total amount • Requested delivery date 	<ul style="list-style-type: none"> • Invoice number • Shipping address • Receipt number • Payment details 	This variant displays the fields necessary for purchase order processing. Fields specific to invoices and receipts are hidden in this variant.
Receipt document variant	<ul style="list-style-type: none"> • Receipt number • Billing address • Item details • Total amount • Date of receipt 	<ul style="list-style-type: none"> • Invoice number • Purchase order number • Shipping address • Payment details 	This variant displays the fields relevant to a receipt. Fields specific to invoices and purchase orders are hidden in this variant.

By creating these document variants, it becomes easier to present and process specific types of documents while ensuring that irrelevant fields are hidden, reducing confusion, and enhancing efficiency in document handling.

Activity variant

You can create an activity variant for a document variant to show and hide fields. This enables multi-stage validation, where multiple resources can validate a document in stages with the visible fields considered valid for the activity but possibly invalid for the document.

Benefits of activity variant include:

- **Enhanced validation workflow:** Activity variants allow for a more granular validation process by showing or hiding specific fields based on the stage of validation. It ensures that each resource focuses on the relevant fields and can provide accurate validation feedback.
- **Streamlined collaboration:** Resources can work simultaneously on different validation stages, reducing dependencies and improving overall efficiency. Each resource can validate its assigned fields without being burdened by irrelevant information.
- **Improved data integrity:** By validating fields at different stages, potential errors or inconsistencies can be identified and rectified earlier in the process ensuring document accuracy.

The Activity variant option is only available when you generate a Take Activity form for a Scan, Validation, Verification, or Document review activity.

You can use an activity variant in a Capture form.

Use case: Create activity variants for the Invoice document variant

In this example, the activity variants are designed to align with the Invoice document variant. Each activity variant represents a specific stage in the invoice processing workflow, tailored to the needs of that activity. The fields displayed and hidden in each activity variant reflect the requirements for that stage, streamlining the validation and review process.

Activity Variant	Fields displayed	Fields hidden	Purpose
Activity: Data Entry Variant	<ul style="list-style-type: none"> • Invoice number • Billing address • Item details • Total amount • Due date 	None	This activity requires a comprehensive view, so all fields are displayed.
Activity: Review and Approve Variant	<ul style="list-style-type: none"> • Invoice number • Billing address • Item details • Total amount • Due date 	None	This activity requires a comprehensive view, so all fields are displayed.
Activity: Finance Verification Variant	<ul style="list-style-type: none"> • Invoice number • Billing address • Total amount • Due date 	<ul style="list-style-type: none"> • Item details 	For this activity, item details may not be relevant, so those fields are hidden.
Activity: Payment Verification Variant	<ul style="list-style-type: none"> • Invoice number • Billing address • Total amount • Due date 	<ul style="list-style-type: none"> • Item details 	For this activity, item details may not be relevant, so those fields are hidden.
Activity: Compliance Verification Variant	<ul style="list-style-type: none"> • Invoice number • Billing address • Item details • Total amount • Due date 	None	This activity requires a complete view of all fields, ensuring compliance with all necessary information.

These activity variants allow for a more focused and efficient validation process, enabling different stakeholders to work on specific stages while considering the relevant fields for their respective activities within the invoice processing workflow.

Additional information about variants

When a document type is used within a Scan, Validation, Verification, or Document review form, the fields configured to be ignored in a document or activity variant do not display and are considered valid for the lifetime of that document. This means that the ignored fields in a document or activity variant do exist on the form but are hidden.

When you design a variant, ensure that the required fields are visible for the multi-field validation rule to execute.

When you apply a validation rule, all fields hidden at the document and activity variant level are considered valid. If you configure a multi-field validation rule and some of the required fields are hidden by the activity variant, and if these fields are used in the multi-field business rule, then the business rule is still executed. However, if a multi-field business rule is mapped to fields hidden by the document variant, then the business rule is not executed.

When you design an activity variant and hide some fields, you will not be able to correct the fields if a multi-field business rule fails.

When you take an activity or create a new job using Scan, the variant is applied to the document at the point of creation and the variant version is set to the latest active version. If the variant does not exist at that point, the document is stamped with the variant, but the version is set to 0. The only way to update the version and apply the variant is to re-classify the document.

You can copy a variant within a document type or from a parent document type to a child and modify it without the need to recreate the entire variant manually.

On exporting a document type as part of a process or package, any configured variants are retained.

On upgrading TotalAgility, any configured variants are available for the existing document types.

Any fields removed from a document type are automatically removed from the variant configuration.

Any fields added while editing a document type are automatically added to the variants of the document type and process but are unmarked as ignored or hidden.

If the activity variant does not exist when the activity is taken, the document variant is applied.

Field formatters

Field formatters are used to force the contents of extracted fields into a predefined format for consistency.

For example, an amount may contain decimals and commas, such as 1,500.00. Use the Amount formatter to reformat amounts to numeric values (1500).

The Amount, Date, and Percentage are used as single-field formatters, whereas the Business rule can be used as a single-field as well as a multiple-field formatter.

TotalAgility provides two default formatters:

- **DefaultDateFormatter:** Contains basic date formatting, such as the date order and date output format.
- **DefaultAmountFormatter:** Contains the default currency and typical decimal symbol formatting.

You can associate a formatter with document or folder type fields, including table columns.

For best practices on formatters, see "Formatting" in *Tungsten TotalAgility Best Practices Guide*.

Field validators

Define the field validators globally and reuse them on specific fields so that you do not have to define the validators multiple times.

You can use the global field validators at the field level of document types and folder types.

Field zoom settings

The field zoom settings let you configure the zoom area for each document field.

If there are any associated zones, you can set the auto-zoom relative to field zone size or set a different zoom level.

If there are no associated zones, you can set which page in the document to navigate to, such as 1st page, last page, or 3rd page, and what area in a page to zoom to, such as the top 20%, the bottom 30%, top-right 10%, or bottom-left 15%.

Document conversion profiles

A Document conversion profile contains conversion settings for converting the incoming documents.

Create a document conversion profile by configuring the required conversion settings for the specific type of incoming documents. The document conversion activity uses the document conversion profile for document conversion. You can create one document conversion profile and reuse the same in various process maps. Also, multiple document conversion profiles can be created to cater to different incoming document types.

Additionally, the Adobe PDF Library SDK smoothing and rendering flags are used for improving the JPEG quality of PDF to TIFF conversion. These flags eliminate the black lines introduced in certain PDF types during document conversion.

PDF profiles

Use a PDF generation profile to improve the PDF output of a document.

You can export images and text to a PDF (Portable Document Format) file, make the output PDF files PDF/A compliant, define the maximum resolution and Image quality, and more. You can add PDF tags to identify text and graphics, convert them to HTML and XML file formats, and ensure interpretation by assistive software for the visually impaired.

Scan/VRS profiles

Use Scan/VRS profiles to store common scanner, normalization, binarization, conversion, and image perfection settings for reuse.

You can also configure advanced eVRS settings to further enhance the image quality, which includes cropping, de-skewing, de-speckling, advanced binarization, and more.

 Tungsten VRS Elite is an image enhancement tool that is used to enhance the quality of images.

TotalAgility provides a default Scan/VRS profile. You can edit the default profile or create additional profiles. You can associate a Scan/VRS profile with a capture-enabled process or use it in scan interfaces, on phone devices, in upload scenarios, and more.

Interaction of Scan/VRS profiles and Web Capture service with VRS Elite

When scanning from a VRS Elite Twain-On-Top source, image processing is disabled in TotalAgility, as VRS Elite handles it. Therefore, image processing must be configured through VRS Elite. VRS Elite then performs image processing before passing the image to TotalAgility.

If a Scan/VRS profile is configured, the same name is used to auto select a VRS Elite profile.

 A scanner workstation CPU can influence VRS scanner performance. A slower CPU slows down scan performance, and a faster CPU speeds up scan performance and brings it closer to the scanner's rated scan speed. Therefore, use a high-end workstation to scan through VRS to scan large documents.

Using Scan/VRS profile for MFP scanning

A Scan/VRS profile can serve two purposes in MFP scanning.

1. Push "Scan settings" to MFP, so that the MFP scan engine uses the specified scan settings. This includes settings such as:
 - Color mode (Such as scan in color, grayscale, or black and white)
 - Resolution
 - Page size

- Page orientation
- Simplex/Duplex
- Page source (ADF or Flatbed)

When an MFP performs scanning, it configures its scan engine to use the corresponding settings.

2. Indicate "Image processing settings", so that when an image is received by TotalAgility from the MFP, it will use eVRS to perform the indicated image processing.

This includes settings such as:

- Output color
- Output resolution
- Auto rotate
- Auto crop
- Blank page deletion
- Deskew
- Despeckle
- eVRS command strings

Separation profiles

Use Separation profiles to separate and automatically place documents in folders during scanning.

Bar code and patch code profiles

Use a bar code or patch code profile to easily access the detected bar codes and patch codes within a process. For example, if a bar code identifies the form type, account number, or department ownership, you may need to extract the bar code value on the scanned page and then use it for downstream processing such as for setting some fields based on the bar code value or routing documents to different reviewers or approvers based on the bar code value.

Control layouts

Use the Control layouts option to create capture form layouts.

The capture control is used for capture activities like Scan, Scan create new job, Verification, Validation, and Document review. A layout can be shared and/or reused between forms of the same capture control type.

 You cannot assign a Scan create new job layout to a non-Scan create new job form.

A layout consists of the following four panels:

1. Navigator

2. Thumbnails
3. Image viewer
4. Fields

You can customize a layout, and swap, dock, resize, collapse, or even hide the layout panels.

 If a Capture form has undocked document, we recommend viewing it using the Chrome browser.

Chapter 9

Translation

The Translation functionality allows you to create a full multilingual solution for the user. You can provide or import translations for multiple languages for artifacts within the solution. You can also use the Generative AI functionality to translate the artefacts.

TotalAgility adheres to the Internationalization (i18n) and Localization (l10n) standards, which define the parameters for adapting computer software to different languages and regions.

The process details, such as activity names within a work queue are displayed extensively throughout solutions; therefore, process elements, such as activity name, SLA description, work types, page renditions, and categories are available for translation. If the Enable multilingual processes setting (System > System settings > General) is not enabled, you can translate the process, but the process will only appear in the base language at runtime.

Forms provide the main user interface to your solution; therefore, each item, such as control text, radio buttons, text fields, check boxes, column headings, navigation text, entities, and table header that is visible to the end user is available for translation into one or more languages.



- On Windows, the Microsoft Virtual keyboard is not enabled when using a text box in password mode.
- On upgrading a form from an earlier version, manually save and release the form to make the Work queue and Job list column headings available for translation.

In TotalAgility, you can define the languages that your process supports for translating items so that you can serve target markets without language and regional restrictions. You can select from the list of languages supported by TotalAgility.



You can select up to 215 languages for translation.

When you add a language and provide translation, at runtime all the data appears in the correct language set for the browser either through browser settings or through the Language selector control. If translations are not available for the browser language, then the elements are displayed in the base language. The Language selector control selections are based on the languages supported by the site.

You can also export and import languages:

- Use APIs in the Job Service component to get or set the language of a particular job.
 - Use UpdateJobLanguage to pass in the job identifier and language code to set the language for the job.

- Use GetJobLanguage to pass in the job identifier to return the language for the job.
- Render any forms displayed in the language of the job by adding a "Set language from job" action.

Add the action to a form and pass in the job ID. This sets the language of the form when it loads. The translation for the language must be available.

Chapter 10

Queries

Queries help you search for required jobs and activities and view the workload for automatic and manual tasks.

You can create the job, work queue, and system queries, and share these queries with specific individuals or groups. The job queries help you search for required jobs, and the work queue queries to search for required activities. The system queries help you view the workload for automatic and manual tasks so that you can take action to avoid delays in processing tasks, and improve performance. You can view the completed work performed in the system and identify and analyze the areas of concern.

Manage the display of the columns in the queries at runtime by selecting the columns and sorting them in the order of appearance or define a custom sort order and specify the direction for each field as ascending or descending.

You can provide permissions to groups or individual resources to run, view, edit or delete a query.

You can configure the query to display the count of items regardless of the retrieval limit specified in the query where the count is the distinct number of activities in the system. For example, if an activity is assigned directly to you and to a group of which you are a member, the activity is shown twice in your work queue even though it is one distinct activity.

When you view the query in a Job list, Work queue, or Workload control at runtime, the total number of items matching the query is displayed. The count of items is displayed in brackets beside the title above the table.

Chapter 11

System

In TotalAgility, you can define categories to group related items, schedule work, and configure many system settings such as retention policy, federated security, exceptions, and SLA. You can add thread pools, manage system tasks, whitelist a web service URL, configure a backup license server, and many other settings.

Use the following links to learn how to configure these settings.

- [Categories](#)
- [Job schedules](#)
- [Deployment servers](#)
- [Deployment schedules](#)
- [System settings](#)
- [Access settings](#)
- [Additional settings](#)
- [GitHub file manager](#)

Categories

Use categories to group related items (from resources to processes) in TotalAgility and provide a means to restrict or provide access.

You can track different types of items that are related but stored in different folders. For example, associate all business processes along with any resources used in the Finance department with the Finance category.

TotalAgility provides the following out-of-the-box categories:

- **Default Category**
- **System Category**
- **TotalAgility Forms:** This category includes TotalAgility Workspace forms and the Management Console sub-category.

For a clean TotalAgility on-premise installation, the Management Console sub-category is available on the Category list for Navigations and Packages by default. For On-premise multi-tenant and Azure environments, the Management Console is not available in the Designer and Workspace. When upgrading TotalAgility, if you select the "Import system Workspace package" option, then both the Workspace package and Management Console package are imported.

If importing the Management Console package manually, make sure to select the "Overwrite non-versioned items" option.

- **Business Rule Parameters:** This category is only available on upgrading TotalAgility, or when you import a logic rule in an older map. Any business rule parameters are imported as server variables and placed in this category.

We recommend that you create custom categories. You can also create categories within categories.

 You cannot delete the Default and System categories; however, you can modify their descriptions.

Job schedules

TotalAgility provides scheduling capabilities with an inbuilt Job Scheduler. You can create your job schedules that can be used to schedule work. A job schedule consists of a process, its initialization data, and frequency of creation.

You can schedule one or more jobs to be created at a specific period or intervals. For example, regular updates to the database, synchronizing with third-party systems, and more.

TotalAgility provides the following job schedules:

- **SYSTEM (do not delete) - AUTO WORK ALLOC:** Performs work allocation automatically.
- **SYSTEM (do not delete) - DELEGATION:** Checks for completed delegation.
- **SYSTEM (do not delete) - Reset Sampling:** Resets quantity counts.

Deployment servers

You can connect your development, test and production environments and automatically deploy solutions or updates between environments. Configure one or more deployment servers, such as test and production. When the solution is ready to be deployed, you can compare both servers to ensure there are no discrepancies and once satisfied can deploy the package to the target server with a single click.

Deployment schedules

Use deployment schedules for continuous deployment of packages to multiple deployment servers. Using deployment schedule, you can continuously deploy packages from one server to another at the scheduled time.

You can configure a notification process to notify the success or failure of the deployment schedule.

Once a deployment schedule is active, the system kicks in the next scheduled time.

When the scheduled time for an active deployment is reached:

- If the deployment is successful, an audit log entry is recorded in the deployment schedule history showing the status as 'Complete'.

- If the execute test plans is set to 'true' and when the test case fails, then no deployment takes place. An audit log entry is recorded showing the status as 'Failed'.
- If the package is deployed and if the deployment fails to one of the deployment servers, an entry is recorded for the failed servers and continue to the next deployment server (if any). For multiple deployment servers, errors for each server is recorded in the audit log entry showing the status as failed with all the error information of the failed deployments. If the deployment fails and if the "Allow solution rollback" system setting is selected, the solution is rolled back.

 You must have the necessary access control list permissions (Write or Full control) to configure a deployment schedule.

System settings

There are various system settings available for use within your system.

These settings are grouped under the following cards:

- [Database, retention and reporting](#)
- [Utilities](#)
- [Process](#)
- [Logon and authentication](#)
- [System](#)
- [User behavior](#)
- [License servers and statistics](#)
- [Capture](#)
- [Apps](#)

Database, retention and reporting

This card includes the following system settings:

- [Database settings](#)
- [Retention policy](#)
- [Reporting server](#)
- [Solution rollback](#)

Database settings

You can view and configure the database settings if you have sufficient access permissions.

Database version

The system displays the database version (read-only).

Write to audit log

Maintains an audit log in the database.

i While audit logging can be useful for monitoring server activity and performance, the audit data can increase the TotalAgility database significantly. You can clear this setting to reduce the database size and increase performance. However, if you do wish to maintain the audit log, configure the associated retention policy to delete the old audit log entries.

Archive mode

When a job is completed (either through natural completion or through termination), it can be archived automatically or manually, with job details from the live tables to the finished tables to improve performance.

- **Automatic** (default): A periodic system task archives the job details from the live to finished tables.
- **Manual**: Archives the finished jobs when you click the "Archive finished jobs" link under [Utilities](#); otherwise, the jobs remain in the live jobs table. See [Archive finished jobs](#).



- You can change the Archive mode from automatic to manual or vice versa. However, it may impact the performance.
- When upgrading TotalAgility, the "Archive finished jobs" property retains the same setting that was set prior to upgrade.

Retention policy

Older and unused items must be removed from the system to prevent unnecessary database growth.

Retention policies can automatically assist in minimizing the database size. Defining the retention period and the number of versions to retain for certain items helps in cleaning up unused items, managing database growth, and optimizing performance.

i Any changes you make in the retention policy are tracked in the audit log entries. On upgrading TotalAgility from an earlier version, the retention settings remain as they were previously set before the upgrade.

Version based retention

By default, the last ten versions of an item are retained and the minimum is 1 version. You can retain several major versions of forms, processes (including skins), business rules, classification groups, extraction groups, Folder types, Document/Activity variants, Data models, Packages, Test suites, and TotalAgility Apps. For example, retain the last 15 versions of a process. You can optionally retain all versions of an item.



- A process version cannot be deleted if there is any job based on it (live or finished).
- The extraction group is not removed even if there are documents that reference it. Therefore, there is no need to check the existing documents.
- When a package is deleted, the associated items remain in the system.
- When a test suite is deleted, the associated business processes remain in the system.
- The activity variants are versioned based on the document type variants, and are deleted along with the document variant versions.

Time based retention

By default, the time based items are set with a custom retention period. You can optionally configure the items to retain indefinitely.

The retention period is the number of days, months, or years for which an item can be retained. Once the retention period is over, the item is automatically removed from the database.

The time-based retention policy relies exclusively on the LastAccessedAt property to determine if a document qualifies for retention. If a document is accessed for read-only purposes, the LastAccessedAt property is not changed. This property is only updated when the document is changed. For example, if the document is changed in Capture Client, the LastAccessedAt property is updated when you complete or cancel the activity. Or, if the document is changed via the SDK call, the LastAccessedAt property is updated when the changes are persisted in the database.

You can define the retention period for the following:

- **Internal users:** Where the end date is greater than the retention period.
- **External users:** Where the end date is greater than the retention period.
- **Audit log entries:** Where the date logged is greater than the retention period.
- **Documents:** Where the LastAccessedAt date is greater than the retention period. After document deletion, if there are no documents left within the folder hierarchy, the retention policy also deletes the root folder.
- **Folders:** Where the LastAccessedAt date of the root folders is greater than the retention period (the value from document retention is used) and if the folder hierarchy does not contain any documents, and the folder hierarchy does not contain locked folders.



- The retention policy does not delete the subfolders separately; they are deleted as part of root folder that matches the retention policy.
- The retention policy does not delete Online Learning folders or their subfolders.

- **TCM packs:** Where the created date is greater than the retention period.

You can configure the retention period for a specific process to get jobs purged by the Retention Policy system task.

Document based retention

By default, the document retention period is set to six months. You can optionally configure to retain the documents indefinitely.

When the retention period runs:

- For all document types that do not have specific retention settings, the general retention behavior based on the "Last Access Time" timestamp and the period set in system settings is used.
- For all document types with a specific setting to use "Last Access Time" or "Finished Time", the retention policy deletes the document based on the settings configured for the latest version for that specific document type.
- If the retention policy deletes all documents from the root folder, the root folder is also deleted.
- The root folder is deleted if it has no documents (even with empty subfolders) and its "Last Access Time" is older than the general retention period configured for the documents. The online learning folders are not deleted during retention policy execution.

Retention process execution

The Retention Policy system task handles deleting items from the database.

The retention policy always deletes all the documents found, that are ready for deletion. It splits these documents into chunks according to the default "Retention chunk size" setting. A single TotalAgility system task executes a chunk of documents. This is needed as the time limit for the single system task is five minutes. For example, if you have huge hierarchies with a lot of data, the system task may fail to delete the default 250 documents within 5 minutes. In such a case, the chunk size can be decreased. The smaller this number is, the more system tasks are created, or vice versa.

Reporting server

The Capture data is stored in a Reporting database. You can define how this data should be handled.

 In an on-premise multi-tenant environment, the "Enable Reporting" feature and the retention period settings (for documents and unprocessed incomplete messages) are not available in the TotalAgility Designer (System setting > Reporting Server). These settings are available on the "Create Tenant" page of the Tungsten TotalAgility Tenant Management System. See the *Tungsten TotalAgility Tenant Management System Help* for more information.

Enable Reporting

By default, **Enable the Reporting feature** is clear, which means all the reporting server settings are not enabled. Select this option to enable sending the information for the Reporting component and processing Reporting messages. setting. If you try to clear the setting once enabled, you are prompted to confirm deleting any unprocessed reporting data from the staging database before saving the change. You can choose to delete or retain the data by selecting either option.

- Yes: All the reporting data is deleted and cannot be recovered.
- No: The unprocessed reporting data is retained in the staging database.

Reporting warehouse ETL agent

The period within which the Reporting service performs the Transform and Load steps of the whole Extract/Transform/Load process.

By default, these steps are executed between 0 Hrs 0 Mins and 23 Hrs and 59 Mins.

For the on-premise multi-tenant and Azure environments, the system tasks are created per-tenant basis with a one-minute interval between the tasks for one tenant. Each task is handled separately, and appropriate pairs of Staging/Warehouse databases are processed with one pair per system task.



- This setting is configured once per TotalAgility installation for an on-premise environment, and per tenant for on-premise multi-tenant and Azure environments.
- Using this setting, you can narrow down the processing of only the Warehouse database to tenants' nightly hours and improve Warehouse database availability for customers.

Data retention period

Specify the following for Data retention period:

- **Documents:** The period for which the data associated with the documents can be stored. (Default: 30 days)
- **Unprocessed incomplete messages:** The period for which the unprocessed incomplete messages can be stored. (Default: 30 days)

Reporting escalation

You can set the thresholds to launch the escalation process.

- **Maximum single increase:** The maximum single increase value of the Reporting escalation. (Default: 50,000, minimum set to 10000)
- **Consecutive increase:** The consecutive increase of the Reporting escalation. (Default: 3, and minimum set to 1)
- **Escalation process:** Select a process to launch for Reporting escalation.

If the required process is not available, you can create a new process with the specified name. On clicking **OK**, a new process is generated with the following input variables as initialization parameters.

Initialization parameter	Variable type	Purpose
ESCALATION_REASON	String	The reasons for escalation such as "Daily threshold value is exceeded", "The count of consecutive increases", "Data loss imminent", and "ETL (Extract, Transform, and Load) processing issue."
MAX_SINGLE_INCREASE	Long	Maximum single increase of Reporting escalation.
CONSECUTIVE_INCREASES	Long	Number of consecutive increases.
NO_OF_WSA_MESSAGES	Long	Number of WSA (Web Security Appliance) messages nearing removal.
NO_OF_ETL_JOBS	Long	Number of ETL jobs that are not completed.

Reporting tags

A reporting tag added to a process enables Tungsten Analytics for TotalAgility to apply a custom filter on a report.

The name of a reporting tag cannot be more than 50 characters.

You can update or delete a reporting tag.

Solution rollback

Use **Allow solution rollback** to rollback a solution if an error occurs on package import.

Utilities

This card includes the following system settings:

- [Archive finished jobs](#)
- [Protected items search](#)

Archive finished job

When a job is completed (either through natural completion or termination), it is possible to archive all details relating to this job from the live tables to the finished tables to improve performance.

The finished jobs can only be archived if the archive mode is manual. See "Archive mode" in [Database settings](#).

Protected items search

You can search for the protected items and view the associations for these items to identify all instances an item is being used.

Search for the protected items by the item name or by the following item types: Process, form, business rule, extraction group, classification group, folder, form template, and custom service.

You can protect the items when creating a package. When you import a package on a different system, you can search and view the list of protected items. The protected items are not available to view within the Designer; therefore, it is not possible to know if these items are in use within a process, form, or business rule. For example, you may be prevented to delete an item that is in use within a process.



- The search is based on the highest versions of the item. For example, if version 1 of TestProcess is protected but version 2 of TestProcess is not protected, the search result does not return TestProcess.
- Associations are not available for extraction groups, classification groups, folders, and form templates, but forms associated with these items are displayed.

You can also delete an item directly from TotalAgility. You can only delete a single item at a time; and cannot delete a protected item that is in use.

Process

This card includes the following system settings:

- [Exceptions](#)
- [Process node colors](#)
- [Scripting](#)
- [SLA and work assignment](#)
- [Auto arrange](#)

Exceptions

An exception is a way of escalating to the user when a particular situation arises within the running of a process.

For example, an exception is raised if the system is unable to connect to a remote server to download important data, or if no resource is available to pick up a particular job.

You can handle an exception by assigning a process map as an escalation process. For example, configure an Insurance Premium Policy process to automatically send an email if customers do not submit their insurance premiums by the due date.

TotalAgility provides predefined exception-handling codes. Each exception code is a placeholder for a particular type of exception (process map). You can use these exception codes in your map to address unexpected events, such as throughput, capacity, and workload changes, without manual intervention or process termination.

You must create the process map to run whenever the exception code is called. For example, the exception code EXP0001 is called whenever a resource has been inactive for an excessive period.

Process node colors

You can set the standard colors for various activity types within the process for ease in identifying the activity type.

By default, the node color for the manual, automatic, integration, and miscellaneous activities is blue (HEX: #E3EDF3, R: 227, G: 237, B: 243, and A: 100).

You can change the node color for all the activities belonging to a node color group. For example, to change the node color for all the Capture activities available in the Manual group, click the selector arrow and select the color, and then click Apply.

See the following table for the activities belonging to a node color group.

Activity	Activity type	Activities
Manual	General	Ordinary activities
	Capture	Document review, Scan, Validation, and Verification activities

Activity	Activity type	Activities
Automatic	General	CMIS, Complex variable, Create new job, Create subjob, Data access, Data list, Job owner, Job variable, Ready for review, Resource info, Script, Sleep, Synchronization, and XML activities
	Capture	Bar code and patch code detection, Classification, Composite, Document conversion, Export, Extraction, Image processing, Image quality analysis, OCR, PDF generation, and Transfer activities
	.Net	.NET, Business Rule, Delete, Document creation, Email, Expression, Loop, Mark Finished, Ready for review, RESTful Service, and Supporting info activities
	Web services	Web service activity
Integration	Microsoft	All Microsoft activities
	RPA	RPA activity
	SignDoc	SignDoc activity
	TCM	All TCM activities
	Content Manager	All OpenText Content Manager activities
	ControlSuite	ControlSuite activity
Miscellaneous	Other	Embedded process

Scripting

A script is a series of instructions that can be executed in a given language.

In TotalAgility, you can associate VBSCRIPT, C#, and VBNET scripts with an activity. Once the activity becomes active, the associated script is executed. VBSCRIPT is not supported in an on-premise multi-tenant environment.

You can enter the data exchange script for CSHARP and VBNET script activities. This script can either be executed before executing the script entered for an activity or it can be executed as part of the script for the activity.

If you want to use SParms in the text of the script activity then you must use the Preload and run data exchange function option; otherwise, you will have to preload the text manually at the start of the script for the activity. The Preload and run data exchange function option allows executing the data exchange script before executing the script entered for an activity.

SLA and work assignment

You can set the SLA indicators for any job or activity and assign resources manually or automatically.

Service level agreement

Service Level Agreement (SLA) is the visual representation of a threshold status or job and activity state on a job list or work queue.

You can specify fully configurable SLA indicators for any job or activity allowing process participants to rapidly see when processes are at risk of exceeding targets and allowing them to take corrective action if necessary.

TotalAgility supports a maximum of five statuses, which are defined at the server level. Two statuses— Green and Amber are active by default, with the option to include Red, Black, and Purple. The status names, such as Red or Green are configurable.

Activity assignment

You can assign activities to a resource based on the skill level set at the time of creating a resource or the skill level set at the process level, or you may consider resources with any skill level to take the jobs.

Work queue

The maximum number of activity rows to retrieve at a time. For example, if set to 500 and if 1000 activities exist, you can retrieve only 500 rows in a work queue. (Default: 50, Maximum: 5000)

Auto arrange

You can set the processes to automatically rearrange the layout when you add a new node or connect to a different node.

Auto arrange

If selected, automatically rearranges the process layout when you add a new node or connect to a different node in a process. (Default: Clear)

Logon and authentication

This card includes the following system settings:

- [Passwords and logon](#)
- [Multifactor authentication](#)
- [Resource extensions](#)
- [User sessions](#)

Password and logon

You can manage passwords and logon settings within the TotalAgility system. Refer to the *Tungsten TotalAgility Best Practices Guide* for more information on some of these options.

Password

Password format

A format that all passwords must adhere to. The password format can be a regular expression or an inline value.

Examples of regular expression for password format:

- The regular expression for a password format that should have a minimum of 8 characters including at least 1 Uppercase Alphabet, 1 Lowercase Alphabet, and 1 Number:

```
^(?=.*[a-z])(?=.*[A-Z])(?=.*\d)[a-zA-Z\d]{8,}$
```

Valid password examples: **PaSs1234** OR **pASS1234**

- The regular expression for a password format that should have a minimum of 8 and a maximum of 10 characters including at least 1 Uppercase Alphabet, 1 Lowercase Alphabet, 1 Number, and 1 Special Character:

```
^(?=.*[a-z])(?=.*[A-Z])(?=.*\d)(?=.*[$@!%*?&])[A-Za-z\d@$!%*?&]{8,10}
```

Valid password examples: **PaSs@123** and **pASS1234**

Password hashing algorithm

Used to verify the integrity of passwords. It includes two settings:

- **SHA-1:** Cryptographic hash algorithm (the default setting for upgrades).
- **Scrypt:** Password-based key derivation function (the default setting for clean installation).

If you change the password hashing algorithm, all existing user passwords become invalid on saving the changes. Therefore, you must specify the default password, and specify if the password must be updated for all users or only for the current user.

Disable logon without password

In TotalAgility on-premise, a message appears when an unauthorized user invokes any of the Logon SDK methods to acquire the session ID.

Reset password notification process

Use a process (default: SYSTEM Reset Password) to reset the password when a user forgets the password and requests a reset.

Security breach

Force all users to change the password on the next login due to a security breach or a change in the password format.

Logon

Allow multiple user logons

This option allows multiple logins using the same session. For example, you can log on to both TotalAgility Designer and TotalAgility Workspace, or use multiple browsers Windows in the same session to log on to Tungsten TotalAgility Workspace.

Store workspace session ID as cookie

This option allows storing the TotalAgility user's session ID in a session cookie. It enables the session ID to be shared across multiple tabs in the Tungsten TotalAgility Workspace.

 When this setting is selected (default), you should not use the SESSION_ID global variable.

Logon state forms

You can associate a form with a logon state to help the form designer know which form to display next. By default, each state uses a specific form. For example, the "AwaitingChangePassword" state uses the "ChangePassword.form" form.

Account lockout policy

An account is locked if the unsuccessful login attempt threshold is exceeded. The account lockout policy disables a user account if the user enters an incorrect password a specified number of times within a specified time. The lockout prevents attackers from guessing users' passwords and

decreases the likelihood of successful attacks on your network. You can define an account lockout duration. Alternatively, an administrator can manually lock and unlock accounts.

Maximum number of logon attempts

The number of failed logins after which a user account must be locked. A locked-out account can only be used again if it is reset by an administrator or if the lockout duration for the account has expired. You can set a value of failed logon attempts between 0 and 999. A value of 0 indicates that the account cannot be locked. (Default: 5)

Account lockout duration

The number of minutes an account remains locked before automatically getting unlocked. The account lockout duration can range from 0 minutes to 99,999 minutes. A value of 0 indicates that the account will remain locked out until an administrator explicitly unlocks it. (Default: 30 Minutes)

Multifactor authentication

Multifactor authentication (MFA) is a security approach to verify the legitimacy of a user that requires more than one of the following independent authentication factors:

- 1. Knowledge factor:** Something only the user knows, such as the password or security question answers.
- 2. Possession factor:** Something only the user has, such as an email with a passcode or a user-specific cookie on a client computer or device.
- 3. Inherence factor:** Something unique to the user, such as fingerprints or eye recognition.
After the presentation, each factor must be validated by the other party for authentication to occur.

You can enable multifactor authentication independently for internal and external resources. TotalAgility supports the following authentication features for both internal and external resources.

- **Passcode:** Users logging on for the first time are requested to enter a passcode. The passcode is sent to the user through an email and has a limited validity period. On entering the active password, a cookie is added to the user's system, and login proceeds. For subsequent login, the system checks for the valid cookie. If it does not exist, the user must go through the passcode verification again.
- **Password format:** To increase security, a regular expression can be supplied to ensure that any passwords added for resources must adhere to a specific format. This is an optional setting.

Resource extensions

You can extend information held in TotalAgility for all workers or groups by defining metadata at the system level. When you configure a worker or group, you can manage the values held for that supplementary information.

User sessions

A user should have sufficient access permissions to view or edit the user session settings.

System

System session ID

Allows execution of any secure SDK call. For each installation of TotalAgility, a unique system session ID is generated. You can regenerate the system session ID or manually set its value.

Limited user session ID

Displays the default limited session ID and allows the generation of a new limited user session ID.

User

Session timeout

The timeframe in hours and minutes after which the system automatically invalidates a user session. The session timeout only comes into effect when the Process Session Timeouts system task is active, and the TotalAgility Core Worker Service is running.

Batch session timeout

The timeframe in hours and minutes after which the batch times out. This interval is specifically used when performing capture-related work, such as scanning and creating jobs, performing a Scan or Validation activity, and others. (Default: 0 Hrs 30 Mins)

A "batch" is temporary storage for all the documents/folder data changes done when working in the capture form. If the batch times out, you will lose all your changes and may have to start from scratch. You will have to launch the Scan Create New Job form again or take the Scan activity or Validation activity again.

If you want Capture batches to timeout, set the appropriate value or disable the "Process Capture Timeouts" system task.

The batch can timeout independently from the session timeout and indicates the time available to complete the capture activity. If the batch times out when performing an activity, you can still cancel the taken activity and take it again from the work queue.

Timeout warning period

The period before which a warning is displayed to inform that the user session is going to time out. (Default: 5 Mins)

For example, if the system session timeout=1 hour, batch session timeout=30 minutes, and warning session timeout=5 minutes, and if you take a capture activity and leave it idle for 30 minutes, the warning message appears after 25 minutes (5 minutes before batch session timeout of 30 minutes).

 If you are on a Take activity form and the session times out, the activity gets cancelled if you have one session or remains taken if you have multiple sessions.

Session timeout form

A TotalAgility form that informs you about the session timeout and provides a link for you to log in again.

For example, when a user is on a Create new job form and does not perform any action after the session timeout message appears, the message appears until the session times out, based on the timings set in the system settings. If the user clicks OK in the message, the session is reset and the user can perform further actions on the form. Otherwise, the session times out, and the user is redirected to the SessionTimeout form.

i If you are on a Take activity form and the session times out, the activity gets cancelled if you have one session or remains taken if you have multiple sessions.

Resource idle timeframe

Determines how long the system should allow a resource to be idle before raising an event. For example, two hours after a resource declines an activity, an event can be raised to re-offer the same activity to the resource. (Default: 0 Hrs 0 Mins)

System

This card includes the following system settings:

- [General](#)
- [Forms](#)
- [Email server \(SMTP\)](#)
- [Thread pools](#)
- [Whitelist](#)
- [System tasks](#)
- [Secure secret storage](#)
- [Security key](#)

General

This topic describes the general settings, settings for the Transformation Server, and system-related settings.

General

Use business calendar

Allows calculating all job durations and due dates based on the business calendar which is selected separately for each scheduled job.

Allow duplicate email addresses

Allows using the same email address by multiple resources.

If this setting is clear, you cannot create or edit (individual, group, external resource), or import a resource that does not have a unique email ID.

Enable multilingual processes

Allows opening the form in the correct locale when the browser is set to a different language.

i If this option is not enabled, you can translate a process, but the process will only appear in the base language at runtime.

Restrict job access

When this setting is selected, it restricts resources from accessing job properties, viewing associated milestones, variables, states, roles, history, and map details at the process level using view job details functional access.

When functional access prevents viewing job details, the job is not visible in job search results. However, users can still create and restart jobs, view the work type, and take and complete activities.

Heartbeat inactive interval

The interval beyond which, if the Core Worker, Transformation, or Export services remain inactive, the status of the corresponding entry in the Machine names table is updated as "inactive". (Default: 60 minutes, Range: Minimum=1 minute and Maximum=1 day)



- The "Heartbeat inactive interval" should be greater than the "Activity reset timeout interval" of Core worker, Export worker and Transformation services.
- This option is not available for On-premise multi-tenancy and Azure environments.

Inactive machine retention

The interval beyond which if the Core Worker, Transformation, or Export services remain inactive, the corresponding entry is deleted from the Machines table of the database so that you can only view the machines that are active in your deployment. (Default: 365 days, Range: Minimum=1 day and Maximum=5000 days)



- This option is not available for On-premise multi-tenancy and Azure environments.

Max number of activities to return

The maximum number of activity rows to retrieve at a time. (Default: 50)



- The number of activity rows cannot exceed 200. At runtime you can retrieve only 200 rows in a work queue even when 1000 activities exist.
- When you upgrade Tungsten TotalAgility from previous versions:
 1. If the maximum number of activities is greater than 200, the max value is set to 200. For example, if the max number of activities is 237, the max value is set to 200.
 2. If the maximum number of activities is less than 200, the max value is set to the existing value. For example, if the max number of activities is 50, the value is set to 50 itself (existing value).

Max number of jobs to return

The maximum number of job rows to retrieve at a time. (Default: 200)



- The number of job rows cannot exceed 500. At runtime you can retrieve only 500 rows in a work queue even when 600 jobs exist.
- On upgrade the maximum number of jobs is set to 200.

i When you set the retrieval limit globally (through System settings) and locally (through APIs such as `getjobs`, `getactivities`, or `getworkqueues`) the system sets the lowest retrieval limit value among the two settings.

By default, the maximum number of activity rows and jobs to retrieve at a time is 50 and 200 respectively. To return more activities and rows up to a maximum of 32,767, do the following:

- Run the `UpdateIgnoreWQJobListMaxRows.sql`. Running the SQL will automatically set the value of `IgnoreWQJobListMaxRows` setting to true. This setting is available in the `server_setting.xml` from the `server_data` table.
- You can now increase the number of activities and jobs to return. (Maximum is 32767)

i SQL Script will be provided to the user by Technical Support when requested by a user.

Transformation server

Reject documents on exceptions

If this setting is selected, the system rejects the document or page on exceptions. If clear, the system suspends the activity on exception.

Core worker

Auto activity reset limit

Allows you to define the maximum number of attempts to reset an automatic activity. (Default: 5)

i For an Azure environment, the default Auto activity reset limit is 1.

Restrict looping in synchronous

Allows the process to be synchronous so that it only has automatic activities and does not have any manual activities. If this setting is selected, you cannot set maximum loop counts.

Continuous looping in a synchronous job or business rule can cause a high workload on the TotalAgility server. The Maximum loop count allows you to define the number of times an activity can be executed in a synchronous job or business rule to prevent continuous looping. When the loop count reaches the defined limit, the synchronous job is suspended at runtime.

Worker task retry count

Allows you to set the maximum number of retries for a worker task. If the maximum number of retries is reached, the worker task is put into an error state. (Default: 5 and Maximum: 100)

You can view the failed worker tasks from the TotalAgility Workspace and activate or delete a worker task.

Capture data clean-up worker

Operation time limit

The operation time limit for the capture data clean-up worker task when deleting large binary data. (Default: 2 Hrs)

Chunk size

Allows you to set the number of binaries to be deleted. (Default: 500 binaries)

Enable custom sorting

Enables sorting of columns in the work queue, System, and Job list queries.

Appearance

Allows you to upload a Browser tab icon that appears in the browser tab of TotalAgility Designer and TotalAgility Workspace. It also applies to on-premise multi-tenancy and Azure environments. This icon helps to visually differentiate the environments. You can customize the icon on the browser tab.



- The preferred size for the image is 32x32 pixels. The maximum file size allowed for the image is 28.4 MB.
- Images in only GIF, PNG or ICO formats are supported.
- If you do not provide any custom icon, the default Tungsten TotalAgility icon is used.
- If the icon does not display automatically, you may have to clear your browser's cache and reopen your browser for the changes to take effect.

Application analytics

Allows you to opt-out of sending telemetry data. (Default: Clear)

RTTS warm-up job

Allows you to select a warm-up process and upload an image. TotalAgility automatically starts a warm-up job on the uploaded process on launching TotalAgility. During warm-up, the uploaded image is used to start up the Transformation Server and pull the project and execute it, so next time the Transformation Server is ready for use.

Forms

By default, some form settings are set with default values. You can change the values for those settings to suit your configuration.

Form layout settings**Form width mode**

The width mode for a form is **Fixed** or **Percentage** (default). When you create a new form or form template or automatically generate a form, the width mode of the form defaults to this system setting.

The custom forms in Tungsten TotalAgility Workspace are also displayed in percentage or fixed width mode according to this setting. If you change this setting from percentage to fixed or vice-versa, you must delete the deployed forms.

Cell alignment

The cell alignment adjusts the cells on the form. You can align the cells on a form to **Center/Left/Right** or **None**. (Default: None)

Label alignment

The label alignment adjusts the labels associated with controls on the form. You can align the label to the **Top** or **Left**. (Default Top)



- When you create a new blank form, build a form (all form types) or regenerate a form, the cells and labels on the controls appear as per the cell alignment and label alignment settings set in the system settings.
- For a process with activities, but no associated form, the form generated at runtime will appear as per the system settings.

Cell padding

The cell padding adjusts the cell values on the form. You can set the default values for the cell padding on a form. (Left, right, top, and bottom)



- When you try to create or modify a form, by default, the cells are added using the specified values as per the system settings. You can also update the cell values as required from the cell properties.

Caching and performance

By default, the forms are cached on the client-side browser for faster loading performance. Only the most frequently accessed forms are stored in each cache. When the form is reloaded, it is retrieved from the cache and the content is refreshed.

Use form cache

Form caching only applies to Desktop forms.

Use document form cache

Document form caching only applies to Document forms. Improves performance when navigating to a document with a type or changing a document type to one that has already been visited during the session.

Use folder form cache

Folder form caching only applies to Folder forms. Improves performance when navigating to a folder with a type or changing a folder type to one that has already been visited during the session.

Form cache size/Document form cache size/Folder form cache size

The cache size determines the maximum number of each form type to be cached on the client-side browser. As the cache size increases, more memory is used on the client machine. When the number of forms exceeds the maximum number, the least requested form is removed from the cache to add the latest.

Enable document pre-loading

If selected, TotalAgility pre-loads the documents in the background. This improves user interface responsiveness but may result in a higher server load.

By default, TotalAgility does not pre-load documents in the background. This reduces the load on the server, but the user interface responsiveness may be slower.

Minification type

The deployed form size is reduced in TotalAgility forms to be able to perform faster at runtime. However, the minification is still slower while initially deploying the form. You can select either option depending on your requirement.

- **Faster runtime** (Default): The size of the file is reduced, but the initial time for deploying the form is slower.
- **Faster deploy**: The size of the file is bigger, but the initial time for deploying the form is faster.

 TotalAgility automatically deploys the form when a new version of the form is released and the form is then accessed at runtime.

Images and custom images

Base image URL

The location other than the default location from where the system picks up the images.

By default, the images are available in the Images folder in TotalAgility.

 When you add an Image control to a form, the system picks the images from the base image URL set in system settings.

Image refresh duration

An interval to refresh a downloaded image from the database. (Default: 120 minutes)

Images and custom pages are stored as assets within TotalAgility and can be used in forms. When you load a form that uses a custom image or page for the first time, the item is downloaded from the database. On subsequent visits, when a form is requested that uses an image or page from the database, the forms server checks if the image or page has already been downloaded and verifies if the last modified date is greater than the current date-time plus the duration. If yes, the latest image or page is downloaded from the database refreshing the image.

Any updated image or page is then shown on a form until the duration has passed.

Custom page refresh duration

An interval to refresh a downloaded page from the database. (Default: 120 minutes)

Capture form behavior

Confirm / Validate field with TAB key

If selected, enables the use of the Tab key to confirm and navigate to the next Capture field if Disable field navigation is not active in Validation control. Confirming or validating a Capture field using the Tab key improves efficiency. (Default: Clear, which means you must press ENTER then TAB to confirm and navigate to the next field.)

The Disable field navigation behavior takes precedence over the TAB key's normal behavior of navigating to the next field.

Auto-validate field after OCR lassoing

If selected, the system populates the field with the lassoed value and confirms the field. (Default: Clear, which means you must press ENTER after lassoing to confirm the field.)

Highlight entire capture field text on click

If selected, automatically selects the entire contents of a field on clicking into a field. (Default: Clear)

Scroll image viewer with mouse wheel

If selected, enables scrolling in the Capture activity image viewer using the mouse wheel.

Scroll across pages and documents

If selected, allows you to scroll across pages and documents in the Image viewer. (Default: Clear)

You can still scroll and view the top or bottom of a page without moving on to the next page/document.

Use alerts for field errors

If selected, displays the alert messages for the field validation errors at the bottom of the fields panel. The alert messages float over the fields and help preserve more space to display the fields. (Default: Clear)

 If the "Use alerts for field errors" setting is used, the layout configurations for the "Current Error" panel is ignored at runtime.

Default design themes

The default theme to apply to forms (desktop/mobile for touch and non-touch).

Generative AI control style

You can customize the appearance of the Copilot chat window to fit in your corporate style.

Header color

The header color of the Copilot chat window.

Apply gradient

Applies gradient to the Chat window header. (Default: Selected).

Fade to color

The faded color of the header after applying the gradient.

Icon

Allows you to set an icon for Copilot in the Chat window. (Default: Copilot icon).

To select an existing image, click ▾ and select an image on the list, or click **New** to upload a new image file.

Email server (SMTP)

You can configure email settings for the system to allow the email activity in a process to work at runtime. The email can only be sent if the configured details are appropriate.

Thread pools

Thread pools (TP) automate activities (including sleep) by threads in that pool. Each thread in a pool controls a separate automatic activity. Thread pools can also be associated with synchronous maps.

TotalAgility provides a default thread pool for capture and non-capture automatic activities.

The default thread pool contains 16 threads; this means that TotalAgility can execute 16 automatic activities at once. Additional activities queue up on the thread pool queue (TPQ) and execute on a first-come, first-served basis. You cannot modify the name or delete the default thread pools; however, you can change their other settings, and create multiple thread pools.

Multiple thread pools offer the following advantages:

- Lets you put long-running activities onto a separate thread pool. This prevents long-running activities from delaying other short-running activities. For example, with two thread pools, the short-running activities on thread pool 1 do not wait for the completion of the long-running activities on thread pool 2.
- Control the number of concurrent calls, reduce the site size, and minimize potential performance delays. This is useful where an automatic activity uses a third-party object method licensed for a limited number of concurrent calls. For example, an email server may only be able to handle 10 concurrent calls at one time. You could set up a thread pool with 10 threads to efficiently handle the processing of these automatic email activities.

Whitelist

You can whitelist the web service URLs and the database connection strings that can be employed by TotalAgility to make web service calls or run SQL queries against TotalAgility.



This allows administrators to secure their servers by preventing connections to any arbitrary host or ports.



System tasks

System tasks are routine tasks that TotalAgility performs. You cannot create a new system task or delete an existing system task. You can deactivate a task, modify the interval in which to execute a system task, set the timeout interval, and define the system task operating time, as needed. You must have the necessary permissions to configure the system tasks.

TotalAgility performs the following routine tasks.

System task name	When the system task executes
Abandoned Scan Sessions Retention	Handles the retention of abandoned sessions based on the retention interval defined in the system settings. See Scan forms .
Archive/Delete Items	Moves archive jobs from live to the archive database.

System task name	When the system task executes
Capture Data Cleanup	Periodically scans the PendingBinariesToDelete table and creates a new DeleteCaptureBinary worker task for each chunk of binaries. (Default interval and default Timeout interval is 10 Mins) The chunk size is determined by several binaries. You can configure the chunk size in the system settings. See Core worker .
Create Exceptions	Creates jobs on a configured exception map. Also creates jobs or alert tasks configured on triggers at the process level. <div style="border: 1px solid #add8e6; padding: 5px; background-color: #e6f2ff;">  You can configure exceptions at the server or process level. </div>
Create Jobs	Creates jobs configured on business events.
Device Management Cleanup	Cleans up device-related data, such as expired devices and old scan history records. The default schedule to run this task to clean up the scan history is every hour.
Evaluate Jobs	The Core Worker service evaluates jobs on job creation and activity completion.
Generative AI	Polls for the worker tasks of type GenerativeAIProcessTask and adds it to the relevant custom job thread pool to execute any Designer requests for generating processes via Generative AI. <div style="border: 1px solid #add8e6; padding: 5px; background-color: #e6f2ff;">  This system task is not used to execute the Generative AI activity. </div> <p>By default, the system task is inactive with a default interval of 0 Mins. If a Generative AI provider is configured on the Integration menu, the system task is automatically enabled and if removed from the Integration, the system task is disabled.</p>
Ingest	Ingests documents from various sources (Email, Fax, FoIP, File) and creates the specified business processes.
Ingest Local Connectors	Ingests documents from various sources (EWS, IMAP, MS Graph, POP3, Fax, File) via Message Connectors configured in TotalAgility Designer and creates the specified business processes. This system task is available for an on-premise multi-tenant environment and is only used for the Integration Server.
Ingest Shared Connectors	Ingests documents from various sources (EWS, IMAP, MS Graph, File) via Message Connector pools configured in Tenant Management System and creates the specified business processes. This system task is only available for an on-premise multi-tenant environment. (Default and minimum time interval is 1 Minute)
KM Files Fetch	Retrieves jobs submitted to the configured FTP server from Konica Minolta devices.
License Threshold Monitoring	Determines how often to check for license threshold exceptions and raise an alert (default interval: 1 minute). Once the threshold is met and the interval has passed, the exception is raised.

System task name	When the system task executes
Management Console	Periodically records the logged-on user count and document volume used for the tenant so it can be displayed in the Tenant Management System's Management Console. By default, this system task runs every hour.
Monitor Reporting	<p>Monitors the reporting tables at a specified time interval and triggers an escalation process, if any problem occurs. (The default interval is 24 hours and the default Timeout interval is 5 minutes)</p> <p>The system records the row count of the following tables for the last 30 instances:</p> <ul style="list-style-type: none"> • WSA_MESSAGES • OBJECT_AUDIT_FACT • EVENT_DATA_DIM • DOC_SESS_SNAPSHOT_FACT • FIELD_ACCUM_FACT_TABLE <p>When any of the following conditions are met, the job is started for the selected process:</p> <ul style="list-style-type: none"> • WSA (Web Security Appliance) messages count exceeds the maximum daily threshold value. • Consecutive increase of WSA messages exceeds the threshold value. • The count of WSA messages that are older than the retention period minus 2 days, is greater than 1. • If the number of pending ETL (Extract, Transform, and Load) jobs are greater than the number of reporting servers concurrently running, then the job is started to show that the reporting servers are less than the number of pending ETL jobs. <div style="border: 1px solid #add8e6; padding: 5px; margin-top: 10px;"> <p> The "Monitor Reporting" system task is only active if "Enable the Reporting feature" is selected in the "Reporting server". For more information, see Reporting server.</p> </div>
Monitoring	Monitors database at a set time interval and executes multiple checks, for example, whether to fire an exception or trigger.
OAuth Server Token Refresh	<p>Checks the validity of the refresh token for each OAuth server after every minute and renews the token before it expires.</p> <p>You can configure the refresh token validity using the Refresh token validity duration field at the time of configuring an OAuth server. If this field value is set to zero, the refresh token always remains valid.</p> <div style="border: 1px solid #add8e6; padding: 5px; margin-top: 10px;"> <p></p> <ul style="list-style-type: none"> • This task can renew the refresh token only if the OAuth server supports it. • If the OAuth server does not have a refresh token associated with it, for example, the OAuth server details were saved but no authorization was done, then the system task skips renewing the refresh token. </div>

System task name	When the system task executes
Online Learning	Runs automatic Online Learning on the documents marked for online learning during validation. For best practices about the Online Learning system task, refer to "Online Learning System Task" in <i>Tungsten TotalAgility Best Practices Guide</i> .
Perform Auto Activities	Executes automatic activities at a set time.
Process Activities	Performs auto work allocation based on the algorithm selected.
Process Capture Timeouts	Cleans up data for expired document capture sessions in the TotalAgility Workspace.
Process MS Exchange Events	Periodically polls the configured Exchange servers to get the outstanding events processed by TotalAgility. This maintains an Exchange state property for each server so that it gets only new events since the last time it checked.
Process MS SharePoint Online Events	Periodically polls the configured SharePoint online servers to get the outstanding events processed by TotalAgility. This maintains a SharePoint state property for each server so that it gets only new events since the last time it checked.
Process Session Timeouts	Forces users to log off on session timeout.
Process State Actions	Executes action (Restart\Create new job) configured on states.
Reporting	Extracts, transforms, and loads the reporting data from the Staging database to the Warehouse database.
Retention Policy	Marks items for deletion for which the retention period and the versions have exceeded the defined limit, and then deletes those items. This task is executed once every seven days by default; you can set the minimum Interval to one hour. If the item that the system task tries to delete is not deleted, the item is recorded in the Retention Policy Failures table. Failures are cleared automatically when the system task executed the next time.
Scheduling	Executes both job and deployment schedules.

System task name	When the system task executes
Telemetry	<p>Periodically collects data about the application and calls the web service (hosted by Tungsten Automation) to send data from TotalAgility to Tungsten Automation every 24 hours by default.</p> <p>The Telemetry system task collects the following data:</p> <ul style="list-style-type: none"> • Average login time per user. • A distinct number of logged-in users. • Number of users defined. • Total login time across users. • Number of jobs created in the last period. • Number of documents created in the last period. • Number of activities performed in the last period. • Number of documents processed using the predefined document type locator for each tenant. • Number of Apps and Jobs created for each App type (Quick Workflow, Quick RPA, and Quick Capture) . • Name of the App type. • Currently installed TotalAgility version. • Maximum number of concurrent logged-on users. <div style="background-color: #e6f2ff; padding: 10px; margin-top: 10px;"> <p>i</p> <ul style="list-style-type: none"> • Only the data that has changed since the system task ran last is collected. • When the system task runs in a new installation, it gets the existing data based on current time and system task. For example, if the interval is set to 24 hours, it gets the metric data for the last 24 hours. </div>
Transformation Server Execution	<p>Performs the following automatic capture activities: Extraction, Classification, PDF Generation, Image Processing, and Composite.</p> <div style="background-color: #e6f2ff; padding: 10px; margin-top: 10px;"> <p>i This system task is only available for TotalAgility in on-premise multi-tenant and Azure environments. It is not available for TotalAgility on-premise. For an on-premise installation, the Transformation Server service continuously runs when configured to execute the capture activities.</p> </div>
Upgrade Jobs	Upgrades jobs for the requested process versions.
Xerox FtpFetch	Retrieves jobs submitted to the configured FTP server from Xerox devices.

Secure secret storage

You can store encryption keys, TotalAgility integration credentials, and connection strings in an external repository such as Azure Key Vault or AWS Secrets Manager and use it for integrations within TotalAgility.

Security key

A security key is the default key that protects all sensitive data between the Client and Server by encrypting the data. You can generate a new security key if required. You can hold the security key in an external repository Azure Key Vault or AWS Secrets Manager and use it for encryption within TotalAgility.

i The security key should be the same when importing data from another server.

User behavior

This card includes the following system settings:

- [Scan forms](#)
- [Activity forms](#)
- [Capture configurable keys](#)
- [Capture operations](#)
- [Query default](#)

Scan forms

The system populates some scan form settings with default values. You can change the values for those settings to suit your configuration.

i The Scan forms display scan errors reported by the VRS scan source.

File upload

Disable the file upload settings in the TotalAgility Designer to avoid the need to manually modify the Web configuration file (Web.config).

Maximum binary chunk size

Determines the maximum size when a single page of an image or imported file is sent to the server from the scan form.

If the page is smaller than the chunk size, the complete page is sent; otherwise, the page is split into chunks. (Default: 10240 Kilobytes)

- If the file you are importing is too large, an error can occur while processing it. The maximum size limit for HTTP response is 2GB, which is also the size limit for files stored in the SQL server. However, the processing of the file depends on system load and memory usage, and an error can still occur for sizes smaller than 2GB due to the way WCF manages its memory.
- The maximum binary chunk size is not used if TotalAgility is installed with File System storage.

When saving big files in chunks while saving and downloading the Capture data to and from Amazon S3 storage, the minimum chunk size is 5MB. If a lower value is specified in the Designer, a popup error appears, setting the value to 5MB size.

When saving big files in chunks while saving and downloading the Capture data to and from Windows Azure Blob Storage, the maximum chunk size is 100MB. If a higher value is specified in the Designer, a popup error appears, setting the value to 100MB.

Maximum number of upload requests

Sets the number of concurrent upload requests.

The chunked image upload is slower than the whole image upload with the same number of concurrent upload requests. Increasing the number of upload requests increases performance. (Default: 2, Minimum: 1, and Maximum: 2147483647)

 You can configure the Maximum binary chunk size and Maximum number of upload requests settings on a per tenant basis.

Set Tungsten VRS Elite profile from scan profile name

By default, sets the Tungsten VRS Elite profile based on the assigned TotalAgility Scan/VRS profile in the Scan Client, so that you need not rely on scan operators to select the correct VRS Elite profile. This setting only applies to "Scan create new job" and "Scan activity" forms and does not apply to the "Web Capture" forms.

- 
- When you create a Scan/VRS profile with some name on the server and create a VRS Elite profile with the same name on the client machine and configure the Scan Client to work with created Scan/VRS profile, specific VRS Elite profile loads automatically. When the operator begins using the Scan Client scan with the VRS Elite scan source and selects the Scan/VRS profile with a matching name, Tungsten VRS Elite will use the corresponding VRS Elite profile during scanning. Only the name connects the profiles. Settings from the Scan/VRS profile are not applied to the VRS Elite profiles.
 - If the corresponding VRS Elite profile does not exist or there is an error selecting this profile, the Scan Client ignores this and continues scanning without setting the VRS Elite profile.
If a VRS Elite profile was already selected, this profile remains even if another Scan/VRS profile that does not have a corresponding VRS Elite profile is selected

Scan/VRS profile

Set Kofax VRS elite profile from scan profile name

By default, sets the VRS Elite profile based on the assigned Scan/VRS Profile in the Scan Client; you need not rely on scan operators to select the correct VRS Elite profile.

This setting only applies to "Scan create new job" and "Scan activity" forms and does not apply to the "Web capture" forms.

Abandoned scan sessions

Delete scan sessions older than day(s)

By default, automatically deletes all abandoned sessions older than the specified number of days. (Default: 3 Days)

When you scan a large number of documents and accidentally close the browser, navigate away from the form, or wait for too long, the scanned documents are lost. To prevent this, you can resume the abandoned sessions to preserve the scanned data for an extended period. This allows you to resume scanning when you reopen the form. When you open a Scan create new job form, a "Resume an abandoned session" pop-up appears at runtime, prompting you to select one of the previously abandoned sessions. The list contains the name of the scan form, a time stamp, and the number of documents, which can help you find the session you need.

This setting only applies to a "Scan create new job" form.

Activity forms

For the generic activity forms that are system generated, you can display the "Save" and "Complete and next" buttons at runtime when you take the activity. You can also specify the behavior for end of capture activity and allow rotating a page without losing OCR data and field data associated with the page.

Activity forms

Allow save

If selected, displays the "Save" button when you take the activity. The Save button allows you to save the activity changes to your work queue at runtime.

Allow complete and next

If selected, displays the "Complete and next" button at runtime when you take the activity. This button allows you to complete the current activity and take the next activity from your work queue.

 The "Allow save" and "Allow complete and next" options are only available for the generic take activity forms that are system generated.

Allow request automation rule

If selected, displays the "Request Automation Rule" button on the form at runtime when you take an activity that does not have an associated form.

 This setting is only used for generic take activity forms that are system generated.

Display in action bar

Displays the following primary actions on the action bar at runtime.

- **Cancel:** Cancels the activity that you are currently working.
- **Save:** Saves the activity changes if any, to your work queue at runtime.
- **Complete and Next:** Completes the current activity and take the next activity from your work queue.
- **Complete:** You can take and complete an activity.
- **Request Automation Rule:** This option is only displayed on the action bar if "Allow request automation rule" is selected. Using this option, you can request automation of the activity at runtime.



- All the actions are displayed on the action bar irrespective of an associated form available for the activity.
- The "Save" and "Complete and next" actions only appear on the action bar if they are selected when generating the form.

Automation

Enable work queue automation

If selected, enables the rule evaluation. (Default: Clear)

End of capture activity behavior when valid

Show activity settings

Shows the Activity settings dialog box button on the Document Review, Verification, and Validation forms.

End of activity

The behavior that can be set for the end of the capture activity:

- Keep the activity open once the activity is completed.
- Prompt you before automatically completing the activity. (Default)
- Automatically complete the activity without prompting you.

Image rotation

Preserve OCR data on rotate

If selected, enables rotating a page without losing OCR data and field data associated with the page.

Capture configurable keys

Customize the hotkeys associated with commands within the Capture Client control to use both single and double key sequences suited to customer preferences.

You cannot delete a command or modify the name of a command. However, you can customize the hotkeys for a command to increase flexibility.

The hotkeys apply to actions for all form types: Scan, Validation, Verification, and Document review.

TotalAgility supports single key, double key, and pop-up window shortcut key:

- **Single key:** CTRL /ALT/SHIFT (Combination) + Key. For example, CTRL+ALT+S.
- **Double key:** CTRL then CTRL /SHIFT/ALT (Combination) + Key. For example, CTRL then CTRL +SHIFT+S.
- **Pop-up window shortcut key:** Use this shortcut key to display the pop-up dialog in TotalAgility at runtime. CTRL then CTRL/ALT/SHIFT (Combination) + Custom Key. For example, CTRL+SHIFT+J.

You can set up only one key combination to display the pop-up dialog.

i TotalAgility does not support a browser defined hotkey, such as CTRL+C which is the default command for copying.

TotalAgility provides the following default hotkeys for commands.

Command	Hotkey	Command	Hotkey
Activity Settings	CTRL then SHIFT+S	Next Page	CTRL then B
Add Row	CTRL then SHIFT+D	Next Problem	CTRL then Q
Best Fit	CTRL then 1	Next Rejected Document/ Page	CTRL then ALT+P
Cancel Activity	CTRL then X	Next Tab	CTRL then CTRL+K
Change Document type	CTRL then T	Online Learning	CTRL then SHIFT+L
Collapse/Expand the Bottom Panel	CTRL then UP ARROW	Override Problem	CTRL then W
Collapse/Expand the Current Error Panel	CTRL then DOWN ARROW	Previous Document	CTRL then SHIFT+P
Collapse/Expand the Left Side Panel	CTRL then LEFT ARROW	Previous Folder	CTRL then SHIFT+K
Collapse/Expand the Right Side Panel	CTRL then RIGHT ARROW	Previous Page	CTRL, SHIFT+B
Complete Activity	CTRL then C	Previous Problem	CTRL then SHIFT+Q
Complete and Take Next Activity	CTRL then Y	Previous Rejected Document/Page	CTRL then ALT+SHIFT+P
Confirm Document Type	CTRL then SHIFT+T	Previous Tab	CTRL then CTRL+J
Create Job	CTRL then SHIFT+C	Print	CTRL then ALT+I
Display Annotations	CTRL then E	Reject Document	CTRL then R
Download	CTRL then ALT+S	Reject Page	CTRL then SHIFT+R
First Document	CTRL then F	Replace Page	CTRL then U
First Folder	CTRL then J	Restore Problem	CTRL then SHIFT+W
First Page	CTRL then A	Revert View	CTRL then SHIFT+DOWN ARROW
Fit Page to Height	CTRL then 3	Rotate Displayed Image 180	CTRL then M
Fit Page to Width	CTRL then 2	Rotate Displayed Image Left	Ctrl then G
Force Valid	CTRL then V	Rotate Displayed Image Right	CTRL then SHIFT+G

Command	Hotkey	Command	Hotkey
Get Source File  This command is not enabled for the upgraded forms.	CTRL then SHIFT+O	Rotate View 180	CTRL then SHIFT+UP ARROW
Go to Document Type	CTRL then 7	Rotate View Left	CTRL then SHIFT+LEFT ARROW
Go to Fields Panel	CTRL then 6	Rotate View Right	CTRL then SHIFT+RIGHT ARROW
Go to Image	CTRL then 8	Scan All Sheets/Import Files	CTRL then O
Go to Navigator	CTRL then 9	Scan One Sheet	CTRL then S
Go to Thumbnails	CTRL then 0	Select All Rows	CTRL then SHIFT+H
Help	CTRL then H	Set Field To Not Verified	CTRL then SHIFT+V
Import Files	CTRL then CTRL+O	Show Page Source Image	CTRL then ALT +0
Insert Pages	CTRL then I	Show Rendition Image 1	CTRL then ALT +1
Insert Row	CTRL then SHIFT+I	Show Rendition Image 2	CTRL then ALT +2
Lasso Zoom	CTRL then L	Show Rendition Image 3	CTRL then ALT +3
Lasso Zoom Lock Mode	CTRL then ALT+L	Show Rendition Image 4	CTRL then ALT +4
Last Document	CTRL then SHIFT+F	Show Rendition Image 5	CTRL then ALT +5
Last Folder	CTRL then SHIFT+J	Split Document	CTRL then D
Last Page	CTRL then SHIFT+ A	Swap front and back sides	CTRL then CTRL+S
Merge Document	CTRL then SHIFT+M	Toggle to/from Virtual Field	CTRL then =
Next Document	CTRL then P	View Or Change Scan Settings	CTRL then SHIFT+E
Next Folder	CTRL then K	Zoom In	CTRL then +
Next Invalid Field	CTRL then N	Zoom Out	CTRL then -
Next Not Verified Field	CTRL then SHIFT+N		

Capture operations

You can assign access permissions to resources and groups to permit or restrict access to each Capture action within a Capture composite control.

The following table describes the purpose of each Capture action.

Action	Purpose
Documents	

Action	Purpose
Reject documents	Rejects the documents if the fields are not valid. For example, if the image is smudged and illegible or the value on the image is not valid.
Delete documents	Deletes a document that was scanned in error, is no longer required, or is a duplicate.
Change document type	<p>Changes the type of document.</p> <p>i Since masking of field group and activity variant is based on document type, changing it results in loss of masking based on some of the fields. Changing the document type back to the original does not restore the masking, as field data and associated words are lost when the document type is changed. Also, trying to link fields to words is not possible as the fields that specify masking are hidden. Masking on the image does not clear immediately since the page is not dynamically updated and the masks are removed the next time the image is retrieved in either the current or next activity.</p>
Split documents	<p>Moves a variable number of pages from an existing document into a new document. When documents are scanned using the duplex mode, TotalAgility tries to keep the front and back images of a single paper together.</p> <p>You should have permission to split a document; otherwise, it will prevent splitting the front or back pages of the document.</p>
Split on back page	<p>Separates the back page of a duplex page pair and places it in a new document. Once split, both the front and back page of a duplex page pair appear as a normal simplex page.</p> <p>You should have permission to split a document on the back page otherwise, it will prevent from the splitting of the back pages.</p>
Merge documents	<p>Merges two or more different documents.</p> <p>i When you upgrade TotalAgility, the "Merge documents" permission is only enabled if the "All other batch-editing operations" permission is selected.</p>
Pages	
Reject pages	Rejects the pages of a document.
Delete pages	Deletes a page that was scanned in error, is no longer required, or is a duplicate.
Rotate pages	Permanently rotates the pages of a document.
Folders	
Add folder	Add folders.
Delete folders	Delete a folder that is no longer required or is a duplicate.
Other	
Annotations	Maintains document annotations.

Action	Purpose
Online learning	<p>Selects the documents for online learning.</p> <p>i Online learning is a mechanism to better find and extract content on a page of a document. Dynamically trained content is added to a dynamic knowledge base until it is finally reviewed and published to a published (static) knowledge base. The Online Learning option only applies to a Validation activity.</p>
Override problems	Overrides a field if it cannot be corrected or correcting it can be time-consuming.
All other batch editing operations	Performs general functions such as moving pages, documents, and folders.
Mask and redact images	<p>Grants a resource or a member of a resource group the ability to mask and redact images in the Web capture control, Capture activity forms, and a Scan create new job form.</p> <p>i The Administrators group has mask and redact image rights by default.</p>
SDK only	
Create documents and pages	Creates and copies documents and pages using the CaptureDocumentService SDK.
Modify/Read document	Modifies and adds documents, pages, and updates fields for folders or documents using the CaptureDocumentService SDK. Also, allows SDK users to read Capture data, such as retrieving documents, document fields, and images.
Confirm fields	Performs validation and changes the document or folder field status using the CaptureDocumentService SDK.
Mask and redact images (SDK)	<p>Mask images using the following CaptureDocumentService SDK.</p> <p>Available mask-related CaptureDocumentService SDK methods include:</p> <ul style="list-style-type: none"> • AddPageMaskForField: Adds mask to a page for a word associated with the specified field. • AddPageMaskForRegion: Adds mask to a page to a specified rectangular area. All the obscured words are removed from the page. • GetAllMaskedWords: Returns all words masked on a page • GetAllPageMasks: Returns all explicit masks associated with a page. • RemoveAllMasks: Removes all masks for the specified page. • RemovePageMasks: Removes masks that intersect the specified rectangular area.

Query default

You can set the default query for a job list and work queue, so that at runtime the configured job list and work queue appear selected by default. After setting the default query, when you add new users, the default query is automatically set for the new users. However, the default query does not impact the existing users. Users can change the default query only for themselves, but not for other users.

License servers and statistics

For TotalAgility on-premise, you can view the license servers associated with your system, configure additional license servers as backup and activate the license API keys. You can also reactivate the license on your primary server and backup server if it is about to expire.

i For Designer in an on-premise multi-tenant or Azure environment, the option to activate or reactivate the license is not available; the license is reactivated automatically.

TotalAgility displays the primary license server and backup license server details (if installed). You can set threshold values for a primary server so that you can take corrective actions before running out of volume. If the primary server license fails to connect, the system automatically uses the backup server license. You cannot set threshold values for a backup server.

Capture

This card includes the following system settings:

- [Capture groups](#)
- [Web capture service](#)
- [Thumbnail settings](#)

Capture groups

TotalAgility provides synchronous classification and extraction capabilities that reduce response time and improve performance by storing and processing document data in memory. A user has the option to persist this data in the document repository after classification and extraction.

TotalAgility supports real-time transformation and optimizes performance by:

- Supporting a configuration mode in the Transformation Server that does not poll for pending capture activities and is only used for synchronous processing.
- Allowing the Transformation Server to preload specific Transformation projects.
- Bypassing folder and document structure validation rules.

To use real-time transformation, you must select the **Real Time Transformation Service** mode during the TotalAgility installation.

In the TotalAgility Designer, preload specific Transformation projects.

The Real Time Transformation Service is supported by two TotalAgility SDK APIs: `CreateJobSyncWithDocuments` and `CreateJobSyncWithDocument`. Refer to the SDK documentation for more information on these APIs.

Web Capture Service

You can update the URL for the Web Capture Service when the existing Web Capture Service is outdated or not responding and allow backward compatibility for Web Capture Service.

See [Capture groups](#).

Thumbnail settings

You can increase the thumbnail size on a Scan create new job form which allows you to click on each page to enlarge it in the Image Viewer instead of scrolling through the thumbnails. Increasing the thumbnail size helps to accurately check the scan quality when you scan many pages and perform a scan review.

Apps

This card includes the following system settings:

- [Quick Capture](#)
- [Quick Workflow/RPA solutions](#)

Quick Capture

Quick Capture is a simplified version of the TotalAgility Process Designer and Transformation Designer that is citizen developer friendly and is designed to enable non-technical users the ability to create a capture solution: upload and train sample documents, extract data, and design the workflow that should be used to process these.

You can control the capture solutions that should be available for use within Quick Capture and restrict users from making use of all capture solutions available in TotalAgility.

Quick Workflow/RPA solutions

Quick Workflow is a simplified version of the TotalAgility Process Designer designed to enable non-technical users the ability to create simple processes.

You can control the workflow solutions that should be available for use within Quick Workflow/RPA solutions and restrict users from making use of all processes available in TotalAgility.

You can define the list of workflow solutions for Quick Workflow and Quick RPA in the System settings.

Access settings

In TotalAgility, you can manage access permissions to grant privileges and restrict resource access to TotalAgility Designer, Transformation Designer, different areas of TotalAgility, capture actions, devices, and TotalAgility Apps.

The access settings are grouped under the following card:

- [Access control list](#)

Access control list

On this card, you can assign permission to one or more resources to permit or restrict access to the following:

- Designer

- Settings
- Process
- Business rule
- Work type
- Resource
- Custom forms
- Persona
- Lock status search
- Job clear down
- Capture design
- Devices
- TotalAgility Apps



- By default, the **Administrators** group has full control access to Settings and Job clear down, **Device Users** group has full control access to Devices, and the **Designers** group has full control access to the following areas: Designer, Process, Business rule, Work type, Resource, Persona, Capture design, Lock status search, and TotalAgility Apps.
- If you deny permission to any group a user belongs to, the user is denied access. This is true even if the user is given the permission in a different group. If the user belongs to more than one group, it is the lowest access permission that is used. For example, if you have full access from one group that you are a member of, and read-only access from another, then you can only read, not write.
- Direct user privileges override group privileges. This means, if the user has explicit access permissions, that is used. For example, if an individual has "Full control " and the Everyone group has only "Read" access permissions, the individual will have full control to create and modify items.

Additional settings

Some settings are grouped under the following cards:

- [Database, retention and reporting](#)
- [Utilities](#)
- [Logon and authentication](#)
- [Capture](#)
- [Apps](#)
- [GitHub](#)

Database, retention and reporting

This card includes the following additional setting:

- [Reporting tags](#)

Reporting tags

A reporting tag added to a process enables Tungsten Analytics for TotalAgility to apply a custom filter on a report.

The name of a reporting tag cannot be more than 50 characters.

You can update or delete a reporting tag.

Utilities

This card includes the following additional settings:

- [Job clear down](#)
- [Lock status search](#)

Job clear down

The Job clear down utility is a permission-based capability available to remove live and finished jobs from the database. This utility is typically used in production or test environments to remove test jobs.

The Job clear down option is only available if you have the appropriate permissions.

Lock status search

You can track the locked items based on the item name, item type, and the resource that locked the item. Search for a combination of items, for example, search for all the forms or processes locked by a resource. The Lock and Unlock options enhance control and configurability for items in the TotalAgility Designer. By default, an item, such as a business process is locked when created, to restrict other resources from modifying. Use the Unlock option to allow others to modify items. You can set the access permissions for a resource that can search for locked items. See [Access control list](#).

You can search the lock status for the following item types: Business processes (includes case definitions, case fragments, and custom services), classification groups, data models, document variants, extraction groups, folder types, forms, form templates, form variants, job schedules, packages, and skins.

Logon and authentication

This card includes the following additional setting:

- [Federated security](#)

Federated security

A Federated security system is an arrangement for managing identities and access to resources that span companies or security domains. It avoids identity duplication and security administration at

multiple locations and provides an easy way of managing identities and providing them with access to information and services in a trusted manner.

In a federated system, a group of organizations shares identity attributes based on mutual trust and agreed-upon standards, facilitating authentication from other members of the federation, and granting appropriate access to online resources. Authentication is a process to verify the identity of the users and system processes. TotalAgility uses the federated security system or claim-based identity for authentication.

Capture

This card includes the following additional settings:

- [Page renditions](#)
- [Devices](#)

Page renditions

Use page renditions to save multiple versions of an image in TotalAgility.

You can keep the original image intact and create a binarized version of the image to transform, to improve performance. For example, in medical claims, you can display the overlaid version of the image and the original image to the user simultaneously.

You can associate multiple images with a single page and provide a way to quickly switch among these images.

Number of rendition images

The number of rendition slots. (Default: 0, Maximum:5)

Depending upon the number of slots specified, the rendition slots with default names such as PageRendition_1, and PageRendition_2, are created in the table, in addition to the existing Page Source Image slot.

For example, if the number of rendition images is two, each page can have up to three versions of an image: "Page Source Image," "PageRendition_1," and "PageRendition_2."

 If you reduce the number of rendition images, the last rendition is automatically removed.

You can edit the default page rendition names:

1. Double-click the rendition or select a rendition from the table and click .
The **Name** field displays the default rendition name.
2. Enter a different name for the rendition and click **OK**.
This name is reflected in the toolbar icon tooltips and default image options at runtime.
3. Rename other renditions as needed.

Default displaying image

The default image slot the Capture user interface should display.

 The default displaying image slot can be one of the defined page renditions, or the Page Source Image slot. If the selected default image is not available, the Page Source Image is used.

Devices

You can maintain Tungsten TotalAgility device application settings for multi-function peripherals (MFPs) and mobile devices. Settings include device registration, application download and deployment, device profiles, and other advanced settings.

Apps

This card includes the following additional settings:

- [App status search](#)
- [Solution access default settings](#)

App status search

Use App status search to track the apps that are locked by a resource. You can force unlock an app if needed.

Solution access default settings

Use Solution access default settings to assign a default set of permissions to users and/or groups for modifying or creating any Quick Workflow, Quick RPA, and Quick Capture solution.

GitHub

Use this card to integrate Tungsten TotalAgility and GitHub source control seamlessly.

You can also search for the list of items checked out to GitHub by users provided you have the appropriate permissions.

This card includes the following system settings:

- [Repository](#)
- [Check out status search](#)

Repository

Use the Repository setting to specify the GitHub repository and authorize access. However, before you can work with the repository, you must configure GitHub integration.

Check out status search

Search for the list of items that are checked out to [GitHub](#) by all users so that you can undo the checkout if needed. You can track the list-based item name, item type and the resource who checked out the item. You can also search for the package definition that is checked out to GitHub.

GitHub file manager

Use GitHub file manager to manage the packages and all the artifacts that exist in GitHub.

Chapter 12

Packages

Use a package to predefine the items for your solution.

A package typically implements a Tungsten TotalAgility solution for an industry vertical. A package can include items related to processes, forms, DLLs, resources, data, business monitoring, and system. Additionally, you can include a package within a package and add miscellaneous files to a package. Every time you save a package, a new version is created. Versioning helps a solution designer in tracking changes to the package. You can move a package from one TotalAgility deployment to another together with its constituents and quickly deploy it without much user intervention. You can only include an item once in a package and cannot include duplicate items. You can delete any referenced item.

You can export the latest version of all the package items at once and import them into another system. The package definition is saved so you can easily export the same items again.

A package can include the items listed in the following table.

Processes	Images	Groups	Lookups
Case	Sites	Personas	Regular expression
Case fragments	Custom pages	Work allocation rules	Alerts
Business rules	Folder types	Job queries	Events
Custom services	Field formatters	Work queue queries	Targets
Custom service groups	PDF profiles	System queries	Server variables
Extraction groups	Separation profiles	Packages	Global variables
Classification groups	Scan/VRS profiles	Miscellaneous files	Web service
Forms	Document conversion profiles	System DLLs	Device settings
Categories	Import connections	Job schedules	Transformation settings
Form templates	Import sources	Checklist templates	Export connector settings
Navigations	Field validators	Checklist items	Import sources
Themes	Capture control layouts	Data models	

Style sheets	Individuals  You cannot include external resources.	Document templates	
--------------	---	--------------------	--

You can manage a package in the following ways:

- Automatically add all or selected associated items related to processes, forms, and categories to a package. The items that already exist in the package are overwritten.
- Select the items to exclude from the package. On saving the package, the package data is saved in the TotalAgility database.
- You can quickly add commonly used items or specific item types from a selected artifact to the package, or search for the items that have been modified since a specific date or time, or between certain periods so you can quickly add all or individual items to the package.
- Upgrade from one version to another by importing a package. The non-versioned items, such as checklists, lookups, Scan/VRS profiles, PDF profiles, custom pages, localization strings, personas, formatters, and others get overwritten if they already exist on the target system.
- Compare a package with the system package or with other packages to view the items that have changed between versions. The items which are different and new in the selected packages are highlighted.
- Create a copy of a package.
- Open, modify, lock, unlock and delete a package.
- Add [miscellaneous files](#) such as an installation guide or other items that may be useful for using the package.
- Assign access permissions to one or more resources to grant access to the package. Resources with at least Read permissions can access a package.
- Export a package for reuse.
- Import the entire package or the selected items to TotalAgility.
- Create different deployment configurations for a package to allow the user to define different values for global variables, server variables, web service integrations, device settings (Tungsten Front Office Server settings), transformation settings, and export connector settings based on different types of deployment targets, such as test and production environments. During import it allows the user to overwrite the values based on the selected deployment type when exporting the package.
- Deploy a package to a deployment server. You can compare the results between the current server package and the contents on the selected deployment server and then deploy the package to the deployment server. The deployed package is exported with values and imported to the selected deployment server by applying the import options.
- Add a package definition and its contents to GitHub. You can get the latest version of the package and its contents and check it out from GitHub. You can check in the package and its items to GitHub.
- Protect all or certain items (supported item types listed below) of a package to prevent other users from viewing or modifying them when they are imported into another machine. On upgrading TotalAgility, the system treats all items within the existing packages as unprotected. You can only protect the following types of artifacts in a package: Processes, Forms, Form templates, Business rules, Classification groups, Extraction groups, and Folders.

You cannot do the following for the protected items:

- Grant maintenance access to the protected item when importing a protected item into a target environment. However, it has no impact on the item on the source server.
- Open or modify these items but can consume them (including in a package).
- Modify the maintenance access on these items when exported and imported into another machine either individually or as part of a package.
- View the protected items, such as classification or extraction group, in the Transformation Designer.

 When viewing the package configuration on the target server, the protected settings are not retained even though the items are protected within that system.

Miscellaneous files

You can include supporting documentation such as the installation guide or other items that may be useful for using the [package](#).

You can upload the following file types to a package: MS Word, MS Excel, PDF, ZIP, and PPT.



- TotalAgility supports uploading of files up to 30MB. However, we recommend that you upload files up to 20 MB.
- When you import a package, miscellaneous files are added to the store by default. However, you can save these files to a location on your computer as the miscellaneous documents may contain useful information, such as how to set up a solution.
- When you import an already existing package, the miscellaneous files in the package are overwritten if you have selected to overwrite the non-versioned items.

Solution rollback

The Solution rollback feature provides the capability of rolling back a package to its previous version if an error occurs on import. The solution rollback option is available on the package import and deployment screens, and the auto-import and deployment APIs.

On importing or deploying a package if any errors occur and if the Solution rollback option is selected:

- Any newly added items are removed.
- All versioned items that are imported are removed leaving the original version.
- All non-versioned items that were updated are replaced with the original version.

Patch package

Sometimes a solution needs a fix deployed and you may like to deploy a single item rather than redeploying the entire solution.

A patch package is a simplified version of a package to which individual items can be added.

A patch package has fewer options than the standard package. It does not include deployment configuration, export options, and overview or content settings.

No associated items are included when exporting a patch package; only the items specifically added to the patch package are exported.

Chapter 13

TotalAgility Apps

Using TotalAgility Apps you can deploy a Quick App solution to another server. You can also compare a solution before deploying it.

Chapter 14

Generative AI

TotalAgility supports integration with ChatGPT OpenAI and Azure OpenAI generative AI providers and also provides the capability for integration with any custom LLM . You can integrate Generative AI into your TotalAgility workflows to extract crucial information from documents, draw inferences, and more. This capability supports enhanced decision-making and more informed, efficient, and effective business operations.

In TotalAgility, using Generative AI you can achieve the following:

- Create workflows, business rules, forms, data models, and lookups, and translate them into different languages real-time.
- Upload an image or a file such as csv or text, submit a request, and have Copilot automatically create the initial version of a workflow in TotalAgility that can be extended as required.
- Get insights from chart, tile, table, work queue, job list, and custom the responses to be of specific word count or style.

Chapter 15

Testing

When developing solutions, testing helps to ensure any updates do not unexpectedly break other areas of the solution. You can create a test plan and save test scripts against your artifacts such as processes, cases, case fragments, business rules, and custom services. Then run these test scripts on demand or before deploying into a live environment.

You can create a test suite to execute the [test plan](#) for one or more artifacts.

Chapter 16

Integrate with other systems

TotalAgility can access web services to connect to third-party software applications, connect to relational databases, and use external assembly components within a .NET activity or action.

You can define settings to integrate TotalAgility with external applications and services, such as Microsoft SharePoint, OpenText Content Manager, and CMIS.

Web service references

Use the Web service references to connect to the third-party software applications, regardless of how each web service is implemented.

For example, TotalAgility can integrate with a web service that automatically validates a credit card number or retrieves delivery information from a transportation company for a dispatched order.

When creating a Web service reference, you can specify custom headers so that the custom header is passed to the Third-party web service when the corresponding Web Service or Restful node is executed. A custom header consists of a name and value pair, such as Host: localhost, where Host is the name, and localhost is the value. All SOAP, SOAP WCF, and RESTful web services support custom headers.

You can also use a RESTful service that has an Open API definition in the process/rule/custom service so that you can see the methods/parameters and execute the service successfully. The OpenAPI specification is an API description format for REST APIs. You can write the OpenAPI definitions in JSON or YAML. YAML is recommended because it is easier to read and write. An OpenAPI file allows you to describe your entire API, including the following:

- Available endpoints (users)
- Operations on each endpoint (GET/users. POST/users)
- Operation parameters (that is, input and output for each operation)

You can reuse the existing web service proxies and proxy file names for any web service references used by TotalAgility processes, forms, or packages. Web service proxies are dynamically created at run time.

When the proxy cannot be created for the web reference, when you import a process map, the reference is still imported, and the following message appears: "Web Service failed to create proxy DLL. To fix the issue regenerate client proxy."

When you import processes, forms, or both using packages, if a new web service reference has the same name as an existing web service reference, a message appears.

.Net assemblies

.Net assemblies enable you to use external assembly components within a .Net activity or action.

TotalAgility provides several assembly paths out of the box, under the TotalAgility SDK. You can use the custom build assemblies that might reference other assemblies.

RPA

RPA (Robotic Process Automation) is a platform for application integration and process automation. Integrate TotalAgility with RPA to execute an RPA robot from within a process or a form.

RPA can integrate applications that were not built to be connected and automate processes across such heterogeneous systems, for example, cloud/SaaS applications with premise systems, legacy systems with modern web applications, or back-office systems with partner websites.

Within the RPA product suite, the user can define robots. A robot is an automated workflow designed to accomplish a task involving a data source, such as a website, an Excel document, or a database. After you integrate TotalAgility with RPA, you can execute an RPA robot from within a process or a form.

Custom service groups

Create custom service groups that can be used within custom services. You can add web service references and server variables from within a custom service group and save them to a category.

Insight

You can integrate TotalAgility with Insight to define and deliver reports, dashboards, and business analysis on demand.

For TotalAgility Azure, install Insight for each tenant and use SSL. For more information, see *Tungsten Analytics for TotalAgility Administrator's Guide*.

SignDoc

SignDoc provides solutions for digital capture, management, and verification of signatures to accelerate business processes, eliminate errors, and protect documents against manipulation.

Integrating TotalAgility with SignDoc simplifies information-intensive customer interactions to ensure a fully digital, streamlined, and secure experience.

TCM

TCM (Tungsten Communications Manager) allows you to define, create, manage, and distribute customer communication documents.

By integrating TotalAgility with the TCM product, you can do the following:

- Leverage templates defined in TCM and invoke document creation from TotalAgility.
- Create documents on-demand (through a process) or interactively (through a form)
- Pull data from disparate systems using TotalAgility and pass it to TCM to generate documents.
- Review or re-generate documents before distribution.
- Distribute documents as part of the composition step or later.
- Distribute documents for eSigning using SignDoc.

Import settings

You can configure TotalAgility to receive documents through Cloud file, POP3, IMAP, SMTP, MS Graph, fax servers, folder, and Exchange Web Services. Each external system has configuration settings that create TotalAgility processes when business documents are received.

You can configure the import source settings on the TotalAgility Integration Server in the same way as you would do in TotalAgility on-premise. When the event is raised on the Integration Server, the action is executed on Azure.

Active import sources or passive import connection settings are supported.

For more information about supported input file formats and output file formats.

Active import sources

The active import sources run as services within TotalAgility to accept messages sent from external systems. You can only configure one import source type for each import connection.

Active import sources include:

- Simple Mail Transfer Protocol (SMTP)
- Fax Over Internet Protocol (FoIP)

When you configure the import connector for email, you can create a document directly using the email body. The mime type of the resulting document is determined by the email format (text, RTF, HTML):

- If the email body is formatted as text, you can perform classification or extraction on that document. After performing image processing on the document, you can view the document in any of the Capture Client activities.
- If the email body is formatted as RTF, provide customization to convert the RTF document to a supported format before submitting it to a Capture activity.

- If the email body is formatted as HTML, after processing the image on the document, you can perform classification or extraction on the document or view the document in any of the Capture Client activities.

Passive import sources

Passive import sources are polled by TotalAgility to retrieve messages. You can configure one or more import connections with a Message Connector. Each import connection contains settings for the Message Connector and one or more import sources.

Passive import sources settings include:

- Post Office Protocol (POP3)
- Internet Message Access Protocol (IMAP)
- Exchange Web Services (EWS)
- MS Graph
- Fax
- File
- Cloud File

Linked servers

You can define a two-way link between two separate TotalAgility installations (on-premise, on-premise multi-tenant, or Azure) and move documents between the linked servers to facilitate high-speed remote scanning.

Linked servers can consist of a combination of on-premise, on-premise multi-tenant and Azure. However, on-premise multi-tenancy to Azure and vice versa is not supported.

In a distributed environment (separate Application and Web server), the current and/or Target URLs must reference the Web server.

In on-premise multi-tenant and Azure environments, the current and/or target URLs must reference the tenant.

For more information about License proxy installation, refer to the *Tungsten TotalAgility Installation Guide*.

OpenText Content Manager

TotalAgility provides comprehensive out-of-the-box integration to the OpenText Content Manager system.

 OpenText Content Manager is only available for TotalAgility on-premise; it is not available for Designer running in On-premise multi-tenant and Azure environments.

Integrating TotalAgility with OpenText Content Manager helps users efficiently manage electronic documents and records throughout the entire life cycle of a document—from creation to destruction.

You can connect to one or more Content Manager systems and access one or more file plan locations in Content Manager.

CMIS

Content Management Interoperability Services (CMIS) is a standard that provides interoperability between ECM systems. CMIS is designed to be layered on top of existing Content Management systems and the related programmatic interfaces. CMIS defines a generic universal set of capabilities provided by a Content Management system and a set of services for working with those capabilities.

Different organizations use different Enterprise Content Management (ECM) systems to suit their requirements and budgets. Each ECM system has its design and architecture, standards, and method of interacting with other systems. Therefore, it is often difficult to build a single tool that interacts with the various ECMs using a common interface.

Use the TotalAgility CMIS integration capabilities to integrate with any third-party document management product that supports CMIS standards, for example, SharePoint. This enables you to use a common interface to configure multiple CMIS-compliant systems and to manage different document management products from within TotalAgility.

Also, for TotalAgility to work with a CMIS-compliant site across domains, you must configure SSL.

TotalAgility provides various CMIS integration nodes. Using these nodes, you can:

- Add (upload) a document to a CMIS-compliant site
- Update the properties of a document on a CMIS-compliant site
- Get a copy of a document/check out a document from a CMIS-compliant site
- Search for a document on a CMIS-compliant site
- Cancel the document check out from a CMIS-compliant site
- Check in a document to a CMIS-compliant site
- Create a folder on a CMIS-compliant site

Azure Storage

Microsoft Azure Blob Storage is a cloud-based storage service, designed to store and manage unstructured data as blobs.

You can integrate this service with TotalAgility to configure access to a specific storage account in Azure and test the connection.

Using the Azure Storage integration, you can import documents from Azure Blob Storage into TotalAgility, process them, and export them back to Azure Blob Storage.

Azure Storage is an alternative to the TotalAgility Import and Export Connectors.

See also:

- [Azure blob storage export activity](#)
- [Azure blob storage import activity](#)

Recognition providers

In a cloud-based OCR system, the Azure AI document intelligence service recognition provider is a specialized service that excels in identifying and extracting text data from images and documents. Leveraging advanced algorithms and machine learning techniques, the recognition provider accurately recognizes printed or handwritten text within an image or scanned document. This capability allows businesses and individuals to efficiently digitize and extract valuable information from physical documents, facilitating streamlined data analysis, searchability, and automation of manual processes. Notable recognition providers in cloud-based OCR systems include Google Cloud Vision, Microsoft Azure Computer Vision, Amazon Textract, and various others.

SharePoint

Integrate TotalAgility with SharePoint to increase the efficiency of business processes and improve team productivity. For example, you can upload a document to a document library or automatically start a job when a document is uploaded to a specific document library.

You can perform various actions in a SharePoint system directly from TotalAgility, and you can configure TotalAgility to respond to events that occur within SharePoint.

For TotalAgility to communicate with a SharePoint site, users must have the necessary access permissions. For example, a user with 'Read' permission can only see the list of sites and events but cannot add, modify, or delete anything.

Dynamics CRM

Integration of TotalAgility with CRM helps end users efficiently manage CRM activities, such as creating, retrieving, and updating various business unit entities.

TotalAgility provides comprehensive out-of-the-box integration to the Microsoft Dynamics CRM. You can configure TotalAgility to respond to events that occur within Dynamics CRM.

Exchange

TotalAgility provides out-of-the-box integration to Microsoft Exchange, enabling you to link your mail server to TotalAgility.

This allows you to handle tasks and jobs such as taking and completing a job directly from your inbox, without having to access a separate application.

You can configure actions to trigger when a specific mail event occurs. For example, automatically create a new job on a particular map as soon as an email arrives in your inbox.

i Microsoft Exchange is only available for TotalAgility on-premise; it is not available for Designer running in On-premise multi-tenant and Azure environments.

ControlSuite

You can integrate TotalAgility with ControlSuite to send the document images and document metadata to the ControlSuite server from the ControlSuite activity.

Submitting documents to ControlSuite allows you to take advantage of an expanded set of connectors to document management systems, fax servers, and line of business applications. In addition, you can submit documents to the print queue in ControlSuite, thus allowing you to pick up the documents that support the MFP device with the ControlSuite MFP client installed.

OAuth servers

The OAuth authorization framework enables a third-party application to obtain limited access to an HTTP service, either on behalf of a resource owner by orchestrating an approval interaction between the resource owner and the HTTP service, or by allowing the third-party application (client) to obtain access on its behalf without having to expose its credentials.

The OAuth authorization framework includes the following roles:

- **Resource owner:** The resource owner is the person or application owning the data for sharing. For example, a user on Facebook or Google could be a resource owner and the resource they own is their data.
- **Resource server:** The resource server is the server that hosts the protected resources that can accept and respond to protected resource requests using access tokens. For example, Facebook or Google is a resource server.
- **Client:** A client is an application that makes protected resource requests on behalf of the resource owner and with its authorization. The term "client" here does not imply any specific implementation characteristics, such as whether the application executes on a server, a desktop, or other devices. A client application could be TotalAgility requesting access to a user's Microsoft account.
- **Authorization server:** The server that issues access tokens to the client after successfully authenticating the resource owner and obtaining authorization. The authorization server can be the same as the resource server or a separate entity.

The following image depicts the typical OAuth authorization grant flow.

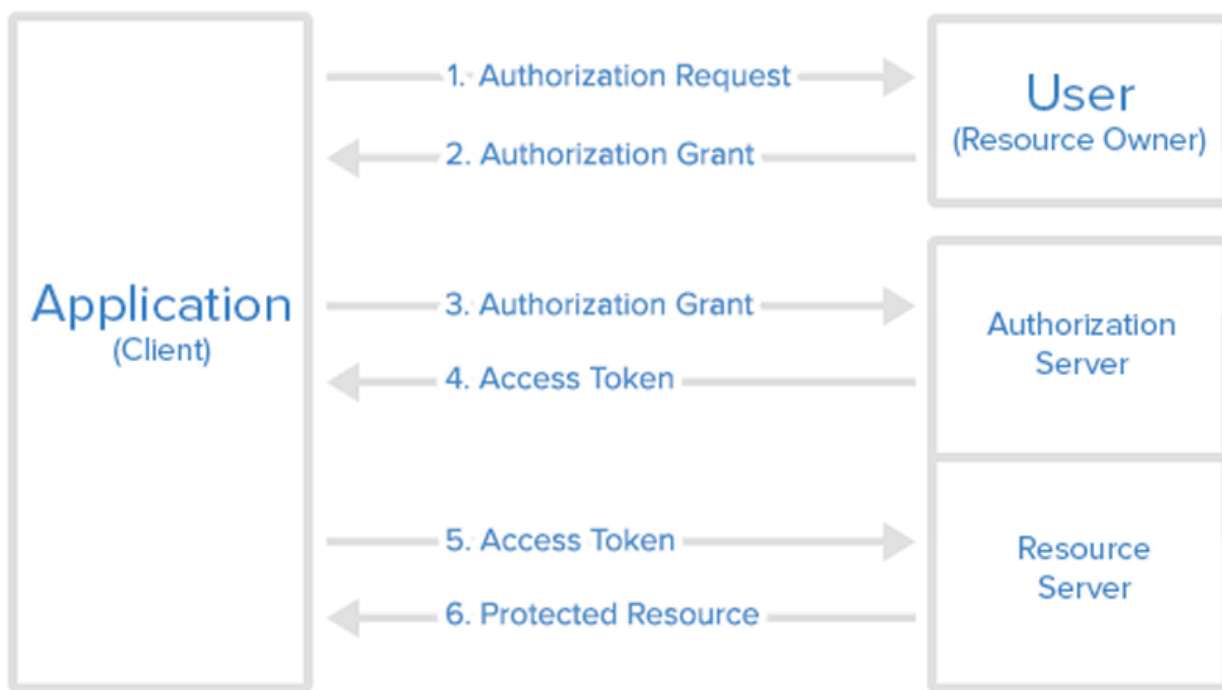

In TotalAgility, you can define OAuth grants and the mechanisms to get authorizations to interact with various Restful web services. In the "OAuth" option available for TotalAgility Web service reference, you can use the configured OAuth authorization grants.

TotalAgility supports the following grant types:

- [Authorization code grant](#) with refresh token grant. TotalAgility automatically refreshes the OAuth access token through a system task without user intervention.
- [Client credentials grant](#) without refresh token grant.
- [Resource owner password](#) grant with resource owner password credentials.

TotalAgility does not support the following OAuth grants and features:

- **Authorization Code grant without refresh token grant:** This grant supports access token generation through manual login or refresh token, but user intervention is not possible during web service execution.
- **Implicit grant:** This grant supports access token generation only through manual login and user intervention is not possible during web service execution.
- Some advanced features of OAuth are not supported directly by Tungsten TotalAgility due to their uncommon usage, but they can still be used through the Custom option in OAuth authentication support. For example, you can authenticate through Assertion-based authentication using JSON Web Token (JWT) with a signing algorithm such as RS512 and RS384.

i TotalAgility does not support SOAP web services for OAuth.

OAuth Authorization Grant types

The authorization grant is given to an application by the resource owner, in cooperation with the authorization server associated with the resource server. Tungsten TotalAgility supports the following OAuth authorization grant types.

Authorization code

This grant type is used to obtain access tokens and refresh tokens from the authorization server and is optimized for confidential clients. TotalAgility supports authorization grants only with refresh token grant which means:

- You should generate access and refresh tokens at design time.
- TotalAgility uses the refresh token to regenerate the access token. It does not require manual intervention.

Client credentials

This grant type is suitable for cases where the client application needs to access resources or call functions in the resource server, which are not related to a specific resource owner. The client can request an access token using only its client credentials, which means the client requests access to the protected resources under its control or those of another resource owner that has previously engaged with the authorization server.

Resource owner password

This grant type is used where the resource owner has a trust relationship with the client. Using this grant type, clients can obtain the resource owner's credentials, username, and password, usually in an interactive form. This grant type is also used to migrate existing clients using direct authentication schemes to OAuth by converting the stored credentials into an access token.

As per OAuth specifications, Tungsten TotalAgility will not save username and password to the database. Hence TotalAgility can support this grant only with a refresh token which means:

- You should generate access and refresh tokens at design time.
- TotalAgility uses the refresh token to regenerate the access token.

TotalAgility Rest API

TotalAgility REST APIs provide greater interoperability between TotalAgility and external systems.

These APIs are documented using Swagger.

To access the REST API documentation, navigate to **Integration > TotalAgility Rest API**.

TotalAgility SDK JSON payload

Use TotalAgility SDK JSON payload utility to generate the JSON payload for the methods on TotalAgility SDK, so that you can use JSON to call the methods using RESTful service.

TotalAgility OAuth clients

The OAuth client represents an external application that accesses TotalAgility REST APIs using OAuth authorization. The external application uses the client ID and secret key to generate an access token request in the appropriate format.

TotalAgility is the authorization server used to generate an access token. The external application passes in the client ID and client secret to get an access token. The access token is then passed by the external application as an authorization header to each TotalAgility RESTful SDK API to authorize the caller. The access token has the same access rights as the TotalAgility system session ID.

The validity duration of each access token is defined in TotalAgility. The external application must generate a new access token periodically by calling TotalAgility passing the client ID and client secret before the token expires.